

Development of a Large-Sized Backlight System for 37V LCD TV

Yutaka Inoue*

* A Project Team, Audio-Visual Systems Group

Abstract

We commercialized the 37" LCD TV LC37BD5 and LC37BT5 in November, 2002. The 37" LCD TV has screen area about 1.5 times the size of the 30" LCD TV that was the maximum size in the previous model. When only the backlight system which enlarged the conventional system simply was used, the problem arose in the brightness uniformity of a screen, and power consumption was not able to satisfy the demand specification. This paper describes an outline about the super long CCFL (Cold Cathode Fluorescent Lamp), the twin inverter system and the new material adopted in order to solve these problems.

Introduction

Development of a backlight system for the new 37-inch LCD TVs began with experimentation using a conventional backlight system prototype. The construction of a 37-inch backlight according to conventional design techniques brought to light the following two problems.

(1) Due to leak current, only the sides of fluorescent lamps closest to the inverter circuit (the circuit driving the lamp) lit up, creating a brightness differential with the grounded side of the lamp. The result was significant variation in the brightness produced on the left and right sides of each lamp.

(2) Attempts to achieve a screen brightness of 450 cd/m² resulted in the power consumption of the backlight system exceeding its value as calculated under the target product specifications by about 20%.

At that point backlight development began with a piece-by-piece reassessment of parts used in the conventional design, focusing on whether changes could be made to alleviate the uneven brightness and improve luminescence efficiency. Reductions were also sought in the backlight system's weight, to the extent that those reductions did not further aggravate the existing uneven brightness and luminescence efficiency issues, since the weight of the backlight increases in roughly direct proportion to its area. The effort to reduce variations in brightness went so far as to involve even a reexamination of the system used to power the fluorescent lamps.

1. Fluorescent Lamps

1.1 The Backlight System

As indicated in **Fig. 1**, two approaches are typically used in backlights for LCD panels: lighting from directly beneath (direct backlight) and lighting via a light guide plate.

The use of a light guide plate provides a backlight that combines a thin form factor with relatively uniform brightness by placing fluorescent lamps at the edges of a light conductor consisting of a transparent acrylic panel. In addition to being unable to provide sufficient screen brightness for large LCD screens due to limitations on the number of lamps that can be physically mounted at the edges of the panel, this approach is

difficult to scale to larger screen sizes as a result of the increasing weight of the light conductor.

On the other hand, direct backlights, which use a series of fluorescent lamps positioned directly underneath the screen, are capable of eliminating the brightness issue since their design allows the number of lamps to be increased according to screen size. However, this approach suffers many problems related to uneven brightness that occurs due to differences in the brightness of the lamps themselves as well as due to differences in brightness between positions located directly above a lamp and positions located between lamps. In order to provide a high level of brightness while maintaining a wall-mountable unit weight, a direct backlight was selected for use in the new 37-inch TVs.

1.2 Fluorescent Lamp Length and Layout

Uneven brightness represents the biggest challenge when using a direct backlight. The most significant cause of these variations in brightness is the interval at which the fluorescent lamps are placed. Increasing the distance between lamps causes areas located between neighboring lamps to darken, producing more pronounced variations in screen brightness. On the other hand, reducing the distance between lamps can produce more uniform brightness but has the unfavorable result of creating heat, cost, and weight issues as the number of lamps increases.

The distance at which the fluorescent lamps are positioned from the screen also affects the uniformity of screen brightness. The greater the distance separating the lamps from the screen, the more uniform the resulting screen brightness becomes. On the other hand, more distance means lower overall screen brightness as well as a thicker overall form factor for the LCD TV.

The following two approaches were considered for the layout of the fluorescent lamps used in the backlight system for the 37-inch TVs. Both calculate the optimum distance between lamps from the amount of brightness uniformity required and the overall backlight thickness.

- (1) 14 fluorescent lamps positioned horizontally, each 850 mm in length
- (2) 26 fluorescent lamps positioned vertically, each 480 mm in length

The amount of power consumed by the lamp electrodes is constant and does not vary with lamp length. As a result, longer lamps are favorable from the standpoint of luminescence efficiency. As indicated by **Fig. 2**, which illustrates the relationship between lamp

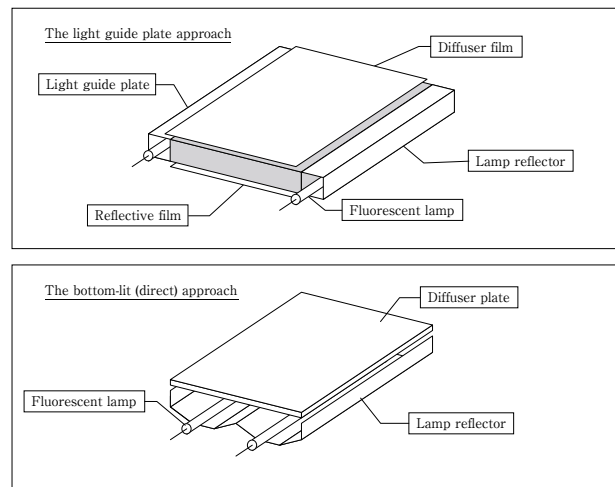

Fig. 1 Backlight system

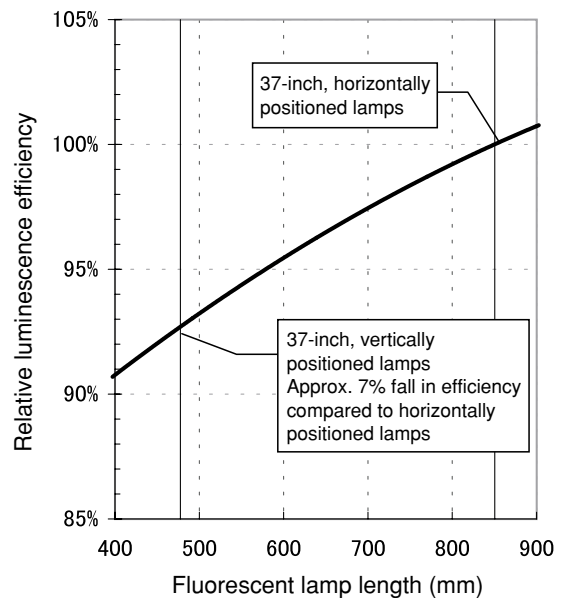

Fig. 2 Lamp length vs. luminescence efficiency

length and luminescence efficiency, the use of 850-mm lamps (1) is characterized by an increase in efficiency of about 7% compared to the use of 480-mm lamps (2). Development of super-long 850-mm lamps began in order to reach project goals related to low power consumption despite doubts about whether they were suited for mass production and how well they would function.

1.3 Lamp Diameter

Fluorescent lamps used in LCD panel backlights typically have diameters in the range of 1.8 to 2.6 mm, with lamp diameters of 2.6 to 3.0 mm considered to provide maximum luminescence efficiency when individual lamps are measured. Experiments with several different lamp diameters for use in direct backlights where the efficiency of the lamps was measured after installation in an LCD TV indicated that lamps with diameters between 2.6 and 4.0 mm operate with generally the same luminescence efficiency. **Fig. 3** illustrates the relationship between lamp diameter and luminescence efficiency.

The use of super-long 850-mm lamps in the new 37-inch TVs required that the lamps themselves have a certain level of mechanical strength. To achieve sufficient strength while maintaining an acceptable level of efficiency, we decided to use lamps with a diameter of 4.0 mm, the thickest possible with glass lamps. The use of thick, 4.0-mm diameter lamps also works to reduce uneven brightness and curb temperature increases in the lamp itself.

1.4 Gas Pressure and Other Considerations

Luminescence efficiency and lamp lifetime are influenced by the type and pressure of the gas with which the lamps are filled. Generally, luminescence efficiency and lamp lifetime tend to be mutually incompatible. Gas type and pressure were selected for their compatibility with the primary requirement of a long lamp lifetime while still maximizing luminescence efficiency in the lamp configuration used by the backlight.

2. The Inverter Circuit (the Circuit that Drives the Fluorescent Lamps)

2.1 Circuit Type

Because fluorescent lamps are powered at high frequencies, current leaks from the lamp via stray capacitance to the lamp reflector and surrounding metallic objects. This leak current increases the higher the voltage and the greater the stray capacitance. Lamp voltage and stray capacitance for fluorescent lamps increase in direct proportion to the length of the lamp. As a result, leak current increases in proportion to the length of the lamp when long lamps are used. In addition to causing the lamp to appear dim the greater the distance from the drive circuit, excessive leak current has an adverse effect on the inverter circuit's power efficiency (lamp power ÷ inverter input power).

When a conventional inverter circuit was used with the new 37-inch TV's 850-mm lamps, the lamps appeared bright only on the side closest to the inverter circuit, causing brightness to vary left to right across

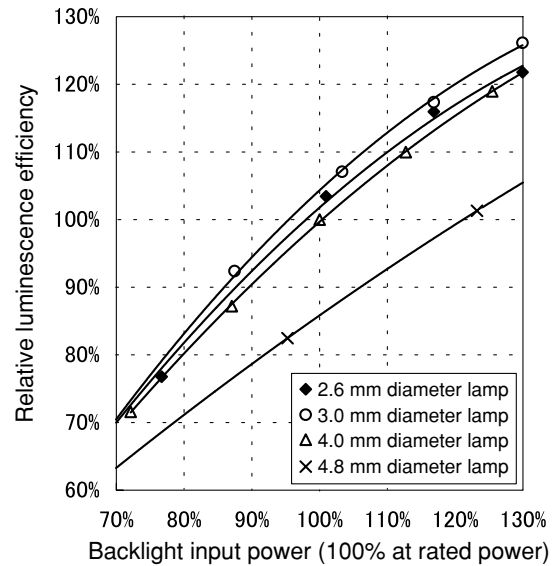

Fig. 3 Lamp diameter vs. luminescence efficiency

the screen. Two methods were considered to address this problem: an alternating inverter approach where the position of the inverter circuit is alternated for neighboring lamps, so that adjacent lamps have their inverter circuits on opposite sides; and a twin inverter approach, where inverter circuits are placed at both ends of each lamp and used to apply voltages that are out of phase by 180° to the same lamp. Fig. 4 illustrates these two types of inverter circuit. Another approach that was considered involved lowering the inverter circuit's operating frequency to increase the impedance of the stray capacitance, thereby reducing the leak current. However, this technique was ultimately abandoned due to the fact that lower frequencies require larger transformers and other parts.

The twin inverter approach allows the voltage and power requirements for individual transformers to be cut in half, since transformers at each side of a single lamp must deliver out-of-phase voltages. The twin inverter approach was selected due to the combination of this advantage with the fact that it is capable of producing more uniform brightness and operating at greater power efficiency than the alternating inverter approach.

2.2 Implementation of the Twin Inverter Approach

The most significant difficulty posed by the twin inverter approach is how to synchronize the voltage phases being applied at the left and right side of each lamp. For example, when the left and right voltage application circuits are located in close proximity to one another, as is the case with U-shaped lamps where there is little space between the left and right electrodes, it is comparatively simple to synchronize both circuits. For the 37-inch TV, the lamp's left and right electrodes are separated by a significant distance of 850 mm. When the signal cables are simply connected out of phase as they would be in a conventional arrangement, accurate synchronization becomes difficult due to noise induction on the sync cable. The solution was to develop a new synchronization method where supplementary windings installed for synchronization purposes on the left and right lamp drive transformers are connected to one another reciprocally.

3. Lamp Reflector

PET (polyethylene terephthalate) sheeting is often used for the lamp reflector (reflector panel) in direct backlights. Reflective sheet made of PET consists of transparent PET that is subject to a gasification process that introduces tiny "grains" of air into the substrate. Light that enters the PET is refracted by these grains and ultimately exits the sheet. Since light is reflected due to the refraction caused by the interface between transparent PET and air, little light is lost, and the material offers a low-cost means of providing extremely high reflectivity.

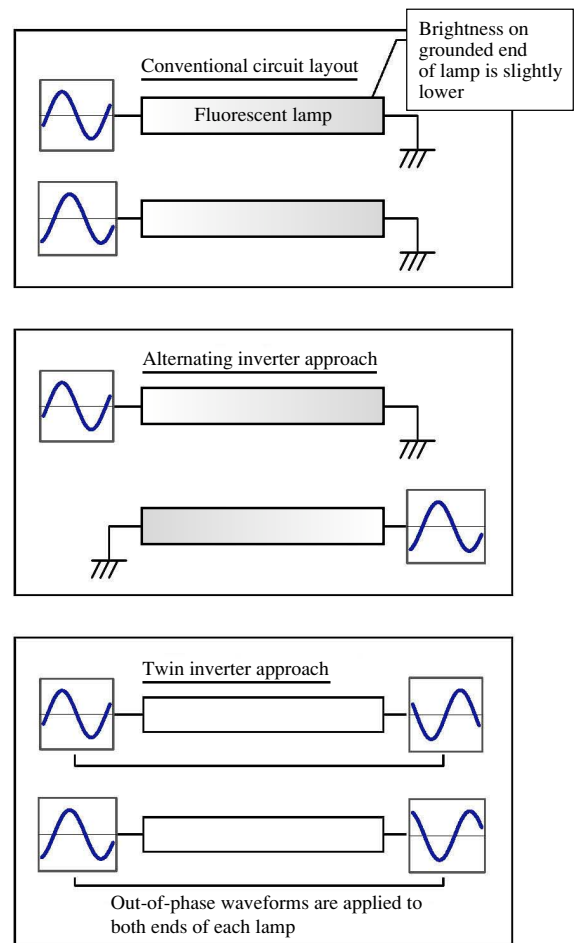

Fig. 4 Inverter circuit

Reflectors used in previous models were manufactured by applying a 0.2 mm thick layer of PET to an aluminum plate and then shaping the entire resulting plate to form the lamp reflector (this 0.2 mm thickness derives from the fact that despite offering higher reflectivity, thick PET applications are more prone to cracking). The new 37-inch TVs use a 1 mm PET coating in order to improve the backlight's luminescence efficiency, resulting in an efficiency improvement of 6%. A new approach is used to create the reflector's shape: the PET sheet is scored and then attached to a metallic plate to ensure it maintains the desired shape.

4. Other Techniques Used to Improve Backlight Efficiency

A brightness distribution control inverter circuit was developed to maintain a natural distribution of brightness on the screen while saving energy by setting the optimum power for individual fluorescent lamps. This circuit has proven capable of maintaining a natural on-screen brightness distribution while reducing power consumption by 4%. In addition, the optical sheet design was optimized, reducing the number of constituent sheets from the conventional 4 to 3.

5. Results

The combination of these techniques resulted in the creation of a screen free of brightness variations as well as a backlight with a high luminescence efficiency. The new design also features a 25% reduction in power consumption compared to conventional backlight designs.

Conclusions

The backlight used by the 37-inch TVs was developed as a super-large backlight solution for the unique demands of the larger screens featured on these models. As LCD TVs grow in size in the future, even more stringent measures aimed at achieving lower power consumption will be required. Against this backdrop, the development of backlight systems will become more important in designing LCD TVs that combine large screen sizes with bright images and low power consumption.

(received Jan. 30, 2003)