

Technology-Development Trend of Liquid Crystal Display

Haruhisa Takiguchi*

*Ecological Technology Development Center corporate Research and Development Group

Abstract

This review article deals with the current and future trend of the technology-development of the liquid crystal display (LCD). To improve the image quality of LCDs, the faster response-time liquid crystal and the higher resolution LCD have been in progress in addition to the enhancement of the viewing angle or the luminance. The reflection type LCD is advancing by improving the reflectivity and the contrast for mobile devices with ultra-low power consumption. LCDs using a plastics substrate or LC on a silicon based LSI substrate (LCOS) is also promising. The research on new liquid crystal modes is being done well. The new device concepts such as a "Digital Cinema" are under development as well as the multimedia displays for personal use. The technological development for self-emissive displays, such as an organic EL or a field emission display (FED) have recently been reinforced besides the rapid progress of the LCD technology. We also review the trend of these display technologies in comparison with LCDs.

Introduction

This paper describes the recent advancement of LCD (Liquid Crystal Display) technologies. Our periodical bulletin SHARP Technical Journal No.69 (1997) carries a report by Funada, et al giving an exhaustive, historical view and future outlook on the development of LCD technologies, and overview and technical movements of other display technologies. This paper focuses on only the latest LCD technologies that have achieved a significant development compared to the previous generation. The author, when preparing this paper, could luckily attend a largest international symposium on display technologies, SID (Society of Information Display) '99 held in San Jose, USA. New LCD technologies and products presented in the symposium are also shown here. Finally, this paper reviews self-emissive display technologies, especially organic EL (Electro-Luminescence) and FED (Field Emission Display) devices that are becoming a strong competitor of LCDs.

1. Electronic Information Displays

Fig 1 exhausts all types of electronic information displays. LCDs are a non-self-emissive, flat panel display. LCD technologies (especially active matrix LCDs (AMLCDs)) featuring a smaller power consumption, higher image quality and completely flat screen are now a core technology requisite for projection type and direct-view type displays. Direct-view type LCD devices on the market range from ultra-small head-mount displays to 40-inch HDTVs. Projection type LCD devices are available also as large theater screens¹⁾.

CRTs (Cathode Ray Tubes), typical self-emissive displays, still account for the largest share among other types of display devices thanks to the higher economy and image quality of CRT technology. In recent years, CRT producers have been active in developing flat type CRTs. PDPs (Plasma Display Panels), a flat type self-emissive display, have now been put into practical use. FED (Field Emission Display) and organic EL (Electro Luminescence) devices are under development. As well as CRTs keeping their leading position in the share of production through continuing efforts for technical development, LCDs have been steadily developed through various technical progress, so that it may not be easy for FED or organic EL devices to come up with LCDs with

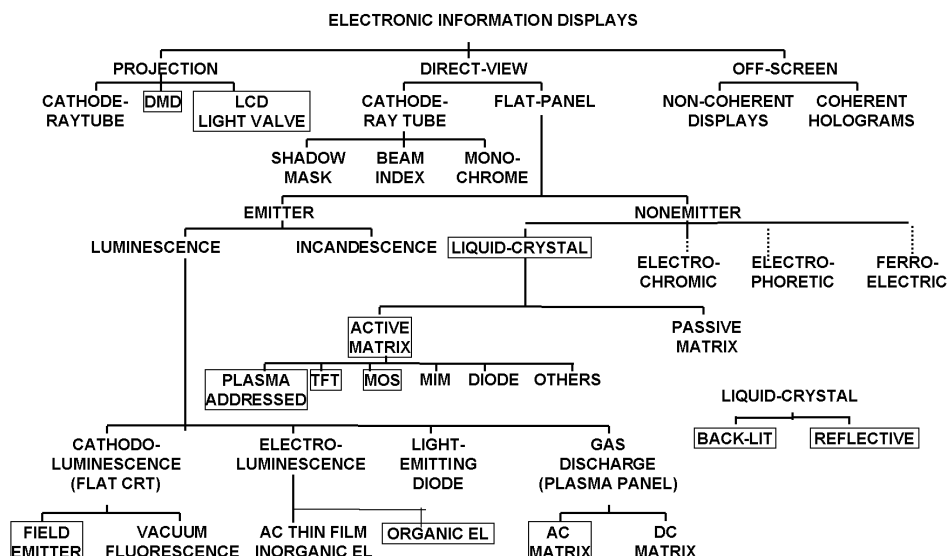

Fig. 1 Electronic information displays (displays in rectangles are discussed here).

respect to the share on the market. However, it is true that these self-emissive FEDs and organic EL devices have been highlighted due to their many advantages such as wider viewing angles and clearer moving images: FED devices have been developed mainly in the USA, and organic EL devices have been developed in Japan, the USA and European countries. The image quality of these devices is already comparable to that of LCDs. In near future, these devices may become a strong competitor of LCDs in some fields of application. PDPs (Plasma Display Panels), a large self-emissive display, have been already on the market. HDTVs are yet to be commercialized, though they have been almost completed. As mentioned above, technical development activities for other electronic information display devices than LCDs are also progressing.

2. Back-Lit LCDs: Improvement in Image Quality

The current mainstream of LCD devices is a transmission type LCD with a backlight. The quality of display is defined by various parameters including luminance, contrast (in both bright and dark environments), viewing angle, response speed and resolution. The present research & development targets are to improve these parameters.

(1) Viewing angle

The largest challenge that has ever been addressed in developing LCD devices is enhancement of the viewing angle, which is small compared to that of self-emissive display devices. Presently available solutions for this problem include multi-domain (MVA) alignment, in-plane switching and compensation films, though they are still under development. Some new ideas for improving these measures were presented at SID'99. One of them is in-plane switching using a fringe pattern, which improves the viewing angle to over 160 degrees²⁾. MVA vertical alignment³⁾ and film-employed compensations⁴⁾⁵⁾ are still under study for improvement. However, since the goals of improving the viewing angles have likely been almost achieved, the next challenge that many researchers will or are addressing is to improve the image quality of moving images.

(2) Response speed

Next-generation LCD devices under study are those available for field-sequential display (time-divided display of RGB), which can eliminate CFs (Color Filters). This display mode does not need CFs and can reduce the number of pixels to one-third that of the present LCD technology, which may enable a higher resolution and larger screen required by the customers. To realize this display mode, it is necessary to shorten the response time of liquid crystal to at least one-third of one frame (16 msec.) (to obtain a quality of commercially available displays, response time must be further shortened to less than half of that amount).

The pie-cell mode, a typical high-speed nematic mode, has been experiment-theoretically designed, which suggests that a high speed of 2 msec. is possible. This is an OCB liquid crystal display mode driven by a low-temperature poly-silicon substrate, aiming at field-sequential display of animation without using a CF⁶). By combining the OCB mode with an organic EL backlight, a field-sequential color display has been obtained, though the red color is not pure (orange). The next challenge is probably a device using a low-temperature poly-silicon material, OCB mode and organic EL backlight, which may enable a full-color display of moving images using a field-sequential technique⁷).

When displaying moving-images, tailing (when an image moves at high speed, it looks as if it has a tail), multiple display images (when it moves at high speed) and crush of high-frequency components are causing images to look unclear. The cause of the first two problems is that the response speed of liquid crystal is slower than one frame (normally 16 msec.), so that the after image is displayed at the next frame. The cause of the third problem is the eye-tracking of a hold-type scanning scheme⁸). To eliminate these problems, higher-speed liquid crystal modes are required.

(3) Resolution

The need for higher resolution is very strong. The recently realized resolution classes for PC monitors are XGA for 10-inch LCDs and UXGA for 20-inch LCDs. To realize these resolutions, technologies for TFT high-aperture rates and Al bus lines have been studied⁹). Application of LPS-TFT has also been studied¹⁰⁾¹¹).

An ultra-high resolution QSXGA (up to 200 ppi) is under development for application in 16-inch LCDs. To realize this, new materials for gates and electrodes (Al (Nd) for gates and Indium Zinc Oxide (IZO) for electrodes) have been proposed¹²), and new types of driving schemes have been proposed¹³). These new materials and drivers have been tested using various performance parameters including smoothness, sharpness and readability of characters to determine the resolution (unit = dpi (dots/inch)). It was reported that it is necessary to raise the resolution to 175 dpi or above to read characters of a size similar to that used for newspapers¹³). This requirement may be incorporated into the standard specifications of the document viewer.

3. Reflection Type LCDs

(1) LCD panel technologies

Since the commercialization of high-quality LCDs of reflection type¹⁴), those comprising a single-polarization-panel, being on the market presently, have been further improved. And, polarizer-less reflection type LCDs enabling a higher lightness are under development toward the next generation of reflection type LCDs. Optical elements for reflection type LCDs have also been developed actively. A single-polarization-panel type LCD that has an inclined reflector inside of each liquid crystal panel to change the angles of the LC-dispersed reflection light to other than those causing surface reflection shows a better performance: the luminance and contrast have been improved 40% and 30% respectively¹⁵). Another single-polarizer type LCD that uses PDLC (Polymer Dispersed Liquid Crystal) for modulating the reflected light has a simpler structure (dispersed type reflection mirrors have been eliminated) and is aiming at better performance: the luminance and contrast have been improved to 30% and 20% respectively¹⁶).

A disadvantage of these single-polarizer type LCDs is that half of the amount of external light around the device cannot be used. Polarizer-less, brighter modes are therefore desired. One solution for this is using HPDLC (Holographic Polymer Dispersed Liquid Crystal) to eliminate the polarizer¹⁷). Keys to this structure, yet to be established, are optimization of the optical conditions for device structure¹⁸) and dispersion of monomers¹⁹). As a method for obtaining gray scale, the possibility of controlling the percentage between the planar state and the focal conic state using cholesteric liquid crystal has been tested. This study demonstrated that an inversion-free gray scale with max. 30% of reflection can be obtained by adjusting the modulating voltage between 0 and 20V¹⁹). Another approach to realizing a polarizer-less mode is the application of the GH (Guest Host) effect. In this case, it is necessary to have multiple layers of liquid crystal in order to obtain a higher lightness. A panel of two layers, 320 dpi, 4-inch diagonal and TFT-driven has been fabricated for testing. The panel shows a reflection of 60% and a contrast ratio of 8:1 for monochrome display²⁰).

(2) Optical elements for LCDs

Various optical elements for reflection type LCDs are now under development. A front-light optical guide of a micro-prism structure available for use with a reflection type LCD at a dark environment has been developed²¹⁾. As an optical element for reflection type LCDs, a new CF (Color Filter) having a four-layer structure comprising three different layers of ITO (Indium Tin Oxide), SiN, and a-Si that is capable of absorbing light has been developed. This CF (red, peak reflection of 90%) shows a smaller spectral shift in reflection spectrum than the existing dichroic mirror type CF²²⁾. A hologram type CF using a volume hologram film in such a manner that external light with an incident angle of 30 degrees can be reflected at the normal direction has been developed. The reflection gain of this CF is 3.5 times as large as that of standard reflection plates²³⁾.

4. Active Drives

(1) TFT technologies

A 2.6-inch panel employing a high-performance TFT (N-channel mobility of $425\text{cm}^2/\text{Vs}$, 80 MHz) based on CGS (Continuous Grain Silicon) technologies, equipped with a digital driver, available for DTV (1,920 x 1,080) projectors, has been under testing²⁴⁾. Thanks to improvements in TFT performance, high-performance drivers²⁵⁾ circuits with functions are expected to develop. LPS (Low Temperature Poly-Silicon)-based LCDs are under improvement toward a higher resolution as mentioned in Section 2 (3)¹⁰⁾⁻¹³⁾. A storage type AMLCD device comprising a ferro-electric material film (PZT) in which writing voltages are stored so that refreshing operations can be eliminated are under study²⁶⁾. This is an interesting approach to achieving a lower power consumption as well as similar-purposed attempts for reflection type LCDs.

(2) LSI-driven LCDs

Reflection type LC panels employing CMOS LSIs (alias LCOS (LC on Si)) have been developed by many producers mainly in the USA. Since LSIs are easily obtainable on the market unlike TFT, even small ventures can participate in this development. In fact, several companies exhibited at SID'99 head-mount type LCOS display devices available for wearable PCs. The LCOS technology using a pixel pitch in the order of several dozens of micro meters, unlike TFT-LCDs using a larger pixel pitch, may cause interference between adjacent pixels due to their electric fields. To verify this problem, model studies²⁷⁾ and observations using a high-resolution camera have been tried. To obtain a higher contrast, the frame reverse method is effective²⁷⁾, though using this method will cause difficulty in switching since the pixel size is as small as 10 micro meters, and resultantly the loss of luminance will become as large as 70%²⁸⁾. To obtain a higher resolution, it is necessary to resolve this problem.

5. Plastic LC

Full-plastics, color LCDs or reflection type color LCDs available for small-package products such as cellular phones have been developed. An advantage of plastic LC materials is that they are bendable. A plastic substrate LC made of phase-separated organic-mixed film (polymer dispersed liquid crystal) is under development²⁹⁾. This product can maintain a contrast ratio of 11:1 even when bent. A study on a method for mounting an active driving circuit on a plastics substrate is under development. This is a method for forming 2-terminal elements (MIM: Metal Insulator Metal) and spin-coated color filter on a plastics substrate (200 micro meter thick PES (Polyethersulfone)) at a processing temperature of 180 to 190 degrees or below. This study has led to a prototype of 2- and 5-inch LCDs³⁰⁾.

6. New LCDs and LC-Related Technologies

(1) LCDs

In addition to existing direct-view LCDs and those for projection, new LCDs using a different display mode have been developed. For example, "Electronic Cinema" that directly projects movies from digital signals without using 35mm film has been commercialized as a liquid crystal light bulb for projectors, ILA (Image Light Amplifier,

brand name)³¹. This is a liquid crystal spatial modulator of a light address type (writing on a CRT) having a performance of 17,000 lumens, a contrast of 1500:1 or over, and resolution of 2,000 TV lines or over. Another new LC device under study is a single-dimension, 1 x 32 beam scanner comprising a 32-layer laminated structure made by laying two different panels - reflection type polarization film of cholesteric LC and retardation film of nematic LC - one after the other and then slicing the pile at angles of 45 degrees³². These new LC devices for new applications will contribute to the further development of liquid crystal devices.

(2) LC-related technologies

New types of optical devices made of liquid crystal material have been studied. One example is a special polarization film mode of a mixture of UV-curable cholesteric LC material and non-light-sensitive nematic LC material. This panel can switch the reflection spectrum between narrow band (40 nm) and wide band (200 nm) by controlling an AC voltage electric field (10V/micro meter)³³. Such technology may contribute to the further development of LCD devices.

7. Flat Type Self-Emissive Display Devices

As mentioned in the introduction of this paper, flat type self-emissive display devices have also been developed actively. By looking into these devices and comparing them with LCDs, we could see the direction of future development of LCD technologies.

(1) PDP devices

This paper does not intend to detail the technical development of PDP devices, but outlines the recent major researches. Recent studies with a view to improving PDP devices are focusing on various aspects including discharging capabilities, device structures, addressing methods, image quality and production processes. PDP devices use a time-dividing process using sub-fields to obtain the gradations of display, which causes the generation of a false profile of moving images due to eye tracking. To reduce this, many sub-fields have been used, which results in a shorter full-emission duration, and a reduction in luminance. One method, under study, for avoiding a reduction in luminance, or improving it while keeping the power consumption at low level is optimizing the number of sub-fields and other specifications using the average luminance at each frame³⁴. These technologies have contributed to prototyping a 60-inch HDTV (16:9 format, 1,366 x 3 x 768 pixels) that can show good performance parameters of 450 cd/m², color temperature of 10,000 K and CR ratio of larger than 500:1³⁵.

(2) FED devices

FED devices based on a principle of letting a phosphor at the anode emit light using a field-emission type electronic emitter in each pixel are a CRT having a flat screen. These devices will be able to have a better quality in the display of moving images as well as ordinary CRTs. An advantage of FED's cathodeluminescence is its greater luminous efficiency. Especially, high-voltage type FEDs, i.e. those using a higher anode voltage, show a luminous efficiency of over 10 lm/W for white luminescence³⁶. FEDs are expected to have a higher quality display and lower power consumption than that of LCDs. A new electronic emitter made of carbon nano-tube³⁶, a possible substitution for the present Spindt type emitter made of molybdenum or silicon, is under study.

To commercialize this new emitter, active researches have been made to obtain a vacuum exhausting technology³⁷ for preventing a fracture due to arc discharges between the gates and cathodes, focusing electrodes that can prevent cross talk between pixels³⁸, and antistatic measures for improving the mechanical resistance of spacers to atmospheric pressures³⁹. These technologies have led to a trial production of a high-quality 5.3-inch FED (320 x 3 x 240 pixels) showing a good - commercialization possible level - performance of 200 cd/m², CR ratio of over 200:1 and power consumption of 2W. This device was exhibited at SID'99. An important challenge that has yet to be addressed is the reliability⁴⁰. Improving the life time of the presently achieved 5,000-10,000 hours³⁶ is the key to the commercialization of this device technology.

(3) Organic EL devices

EL materials are either inorganic (e.g. ZnS (Zinc Sulfide)) or organic. Organic EL materials, injection type luminescent materials, can be used with a low-voltage DC drive, and can emit all colors of luminescence, so that

they are promising as a material of the next generation multimedia display devices. The luminescent material is either polymer (e.g. PPV (Poly p-Phenylene Vinylene) or a low-molecule mass film (e.g. Alq (tri88-hydroxyquinoline aluminum). Polymer materials are soluble in solvent, so that they can be applied by coating, while low-molecular membranes show a higher luminous efficiency. As a duty-drive type display that needs the self-emissive characteristic of an EL material and the function of a diode, a 5.2-inch display (320 x 3 x 240 pixels) of low-molecular membrane has been produced. This product shows a good performance of 150 cd/m², 64 gradations, duty rate of 1/120 and power consumption of 6W. At preset, EL materials cannot achieve the luminance required for display devices with a higher resolution than VGA devices⁴⁰. Therefore, an active-drive system using LPS-TFT technologies has also been tried. The next challenges are to research the possibility of improving the reliability e.g. using less active metals (currently Ag or Mg is used) for electrodes, reducing the driving voltage, and achieving a higher efficiency.

(4) Comparison between LCD and self-emissive display

CRT devices has the longest history of use among electronic display devices, though LCD devices are better for their complete flatness and smaller power consumption. And, LCD devices have been spreading thanks to the continuing efforts to improve the technology levels. However, self-emissive display devices have also been significantly advancing as mentioned before in this section. Comparing the performance of various types of display devices such as LCD and PDP devices may facilitate identifying what points or specification it ems to be improved for each device in order to expand its market. **Table 1** shows a comparison among these devices citing a large display (30-inch HDTV) for reason that this size will probably become typical for a multimedia display in the near future. Parameters used for this comparison are the quality of image displayed, other commercial values, reliability and practical size.

The peak luminance performance is the possibility of increasing the luminance to around 700 cd/m² when displaying a very luminous (bright) point (e.g. the sun). PDP, FED and CRT devices can display such luminous images by intensifying the luminance signals of only the images. On the other hand, for back-lit LCD devices, to raise the peak luminance, it is necessary to keep the high-luminance back light turned on, since the maximum luminance is determined depending on the luminance of the back light. This suggests that LCD devices need a larger power consumption. Though the level of peak luminance required for multimedia displays has not been determined, it is apparent that self-emissive display devices are more preferable as they can easily respond to any levels of peak luminance. Totally white luminance is the luminance when displaying an entirely white screen. To

Table 1 Specifications of various type of large size FPDs (as in the year 2003).

		Minimum required performance level (◎,○,△)	TFT LCD	PALC	PDP (AC type)	FED	32 type CRT
Development level in 2003			Mass production	Mass production	Mass production	Mass production	Mass production
Quality of display	Peak display performance	—	—	—	◎	◎	◎
	Peak luminance(cd/m ²)	300<○<500	◎	◎	○	○	◎
	Totally white luminance(cd/m ²)	160<○<400	◎	◎	△	○	○
	Contrast in brighter environments	70≤○<100	◎	◎	△	○	◎
	Contrast in dark environments	250≤○<350	○	○	◎	◎	◎
	Gray- scale capability	○=8bit	◎	◎	◎	◎	◎
	Viewing angle (degree)	120<○<160	○	○	◎	◎	◎
	Response speed	○<12m sec	△	△	○	◎	◎
Other commercial values	Depth (cm)	○<6cm	○	○	○	◎	×
	Average power consumption (30 type) Non-self-emissive: totally white 500cd/m ² Self-emissive: totally white 200cd/m ² (Peak luminance 600)	100w<○≤150w	◎	△	△	◎	○
	Life (for the same conditions as above)	30,000 hours<○<50,000 hours	◎	◎	○	??	◎
Practical size			~30	30~60	30~60	4~30	~33

increase the luminance of the entire screen, it is necessary to use a more powerful drive circuit, which results in an increase in cost. This is true for both self-emissive and LCD devices.

For PDP devices, it is difficult to increase the totally white luminance due to the nature of PDP technologies. In bright environments, that is a contrast obtained when viewing a display in the daylight, LCD devices are superior to self-emissive display devices. The contrast of self-emissive display devices under bright environments cannot be improved to the level of LCD devices, because the external light around the device reflects on the phosphor material on the surface of the front glass, which results in a rise of the level of "black" state. Installing a light reducing filter in front of the display is not effective for achieving the level of contrast in bright environments obtained by LCD devices. The contrast in dark environments of LCD devices cannot be raised to the level of self-emissive display devices, since it is difficult to restrain the leak of light due to the optical characteristics of liquid crystal. The viewing angle of self-emissive display devices is large for the nature of the device, while that of LCD devices is small even if compensation film is added. The response speed and the moving-image-displaying performance of LCD devices should be improved (see Section 2 (2)). CRT and FED devices are suitable for displaying moving images for the operating nature of these devices. They are thus apparently superior to LCD devices in the field of multimedia displays, especially as TVs in this regard.

Another important requirement is lower power consumption. TFT-LCD and FED devices are better in terms of power consumption. This is because TFT-LCD devices have a larger transmittance, and a highly efficient backlight that can reduce power consumption. FED devices have a larger luminous efficiency than PDP devices.

Information on the reliability and life time for other than LCDs or CRTs devices is less available. According to a paper presented at SID'99, the life time of electronic display devices other than LCDs or CRTs is around 5,000 hours³⁶⁾. A longer service life is required so that these devices can be commercialized. The anode voltage and operating efficiency of phosphors may be one of the keys to improving the life time.

As mentioned above, every display device has some advantages and disadvantages, and has been improved through continuing efforts to enhance the advantages and eliminate the disadvantages to survive in the fierce competition. It is expected that this competition among different devices will give rise to the appearance of such flat FPDs that can meet the specifications required for a multimedia display.

8. New Applications of Electronic Display Devices

One remarkable application of electronic display devices is Digital Cinema. In the keynote speech of SID'99, a movie generated directly from a digital signal was screened using a large projector that comprises light-addressed type liquid crystal panels, ILAs³⁷⁾, for spatial light modulation, and DLP (Digital Light ProcessingTM) elements⁴¹⁾ for mechanical modulation. Using these elements, light of 17,000 lumens is projected on a large screen (15 m wide). However, the quality of images obtained by this digital projector may not be satisfactory compared to the conventional films. Nonetheless, Digital Cinema is expected to extensively spread in near future for its many advantages (easy to transport, duplicate, edit and store). Unlike the existing applications of electronic display intended for personal use or for groups of specified several persons, Digital Cinema is pioneering another way for use of the electronic display - for a large audience. Non-personal, high-end applications, being less subject to cost-wise restrictions, may lead the development of new display technologies for the consumer. One instance of this is the adoption of this technology for home-use projectors.

Another possible high-end application field is medical diagnosing technologies⁴²⁾. Specifications of an electronic display for medical diagnosis have been proposed. According to this proposal, various performance parameters including flicker, luminance of the entire screen, contrast, repeatability of color, and stability should be strictly specified in addition to those mentioned in **Table 1**. The proposal said that the viewing angle should be defined using a new sub-parameter "hue" in addition to the existing CR (>10). Developing technologies necessary for such high-end applications will contribute to the improvement of display quality for general, non-high-end applications.

Conclusions

This paper described the movements of liquid crystal display technologies by referring to various papers presented at SID'99. Current efforts to improve the quality of LCD devices focus on achieving a higher resolution without using a color filter, lower cost, and higher response/resolution in order to improve the quality of moving images, while those to improve the viewing angle have been made as actively as ever. Reflection type LCDs are under improvement toward a lower power consumption. Full-color, plastic LCDs for portable devices (e.g. cellular phones) are promising so that development activities for this type of LCD will become more active. Micro-LCDs (LCOS), a new concept display, intended for "wearable" PCs have appeared, and efforts to improve the technology will continue. New applications including "Digital Cinema" have been explored along with continuing efforts to develop new concepts of LCD necessary for such applications. Applications of LC technologies in other fields than "display" will be explored. Liquid crystal features a lower power consumption and the capability of extensively modulating optical characteristics using a low-voltage drive. Optical active devices using LC technology are expected to be developed.

Following CRTs, flat, self-emissive display devices have also been developed actively. The natures of these devices that LCDs don't have will probably be appreciated by the market. LCD devices have been continuously improved so that their weak points can be eliminated, and they can compete with self-emissive display devices. The author expects that each type of device will gain technical progresses in the competition among these devices and grow in a market where specific capabilities and performance are given the highest appreciation among others.

References

- [1] W.P. Belha, et al, SID '99, International Symposium, Digest of Technical Paper, Keynote Address.
- [2] S.H.Lee, et al, SID '99, International Symposium, Digest of Technical Paper, 16.4L, p202.
- [3] Y. Tanaka, et al, SID '99, International Symposium, Digest of Technical Paper, 16.5L, p206.
- [4] C. Heinmuller, et al, SID '99, International Symposium, Digest of Technical Paper, 10.2, p90.
- [5] H. Seibele, et al, SID '99, International Symposium, Digest of Technical Paper, 10.4, p98.
- [6] N. Koma, et al, SID '99, International Symposium, Digest of Technical Paper, 5.2, p28.
- [7] M. Ogawa, et al, SID '99, International Symposium, Digest of Technical Paper, 53.2, p1098.
- [8] T. Kurita, Japanese Liquid Crystal Society, The first LCD-Forum (in Japanese) 1998 August 28
- [9] S. Nakabu, et al, SID '99, International Symposium, Digest of Technical Paper, 32.2, p732.
- [10] N. Ibaraki, et al, SID '99, International Symposium, Digest of Technical Paper, 15.1, p172.
- [11] Y. Aoki, et al, SID '99, International Symposium, Digest of Technical Paper, 15.2, p176.
- [12] H. Kinoshita, et al, SID '99, International Symposium, Digest of Technical Paper, 32.3L, p736.
- [13] T. Nose, et al, SID '99, International Symposium, Digest of Technical Paper, 15.3, p180.
- [14] Sharp Technical Journal vol.69, p180(1997)
- [15] D-L Ting, et al, SID '99, International Symposium, Digest of Technical Paper, 45.2, p954.
- [16] H. Hiraki, et al, SID '99, International Symposium, Digest of Technical Paper, P-53, p686.
- [17] K. Tanaka, et al, J. of SID, vol.2, p37(1944)
- [18] M. Date, et al, SID '99, International Symposium, Digest of Technical Paper, p-47, p656.
- [19] C.C. Bowley, et al, SID '99, International Symposium, Digest of Technical Paper, 45.3, p958.
- [20] M. Hasegawa, et al, SID '99, International Symposium, Digest of Technical Paper, 45.4L, p962.
- [21] H.J. Cornelissen, et al, SID '99, International Symposium, Digest of Technical Paper, 42.3, p912.
- [22] M. Kim, et al, SID '99, International Symposium, Digest of Technical Paper, 44.2, p940.
- [23] K. Iwauchi, et al, SID '99, International Symposium, Digest of Technical Paper, P-56, p694.
- [24] M. Azami, et al, SID '99, International Symposium, Digest of Technical Paper, 4.1, p6.
- [25] Y. Kubota, et al, SID '99, International Symposium, Digest of Technical Paper, L1.1, p1116.
- [26] M. Akiyama, et al, SID '99, International Symposium, Digest of Technical Paper, 4.2, p10.
- [27] H.C. Huang, et al, SID '99, International Symposium, Digest of Technical Paper, 33.1, p742.
- [28] K.C. Ho, et al, SID '99, International Symposium, Digest of Technical Paper, 33.2, p746.

- [29] J-H. Kim, et al, SID '99, International Symposium, Digest of Technical Paper, 40.3, p880.
- [30] R. Baueuerle, et al, SID '99, International Symposium, Digest of Technical Paper, 4.3, p14.
- [31] R.D. Sterling, et al, SID '99, International Symposium, Digest of Technical Paper, 17.2, p216.
- [32] S.M. Faris, et al, SID '99, International Symposium, Digest of Technical Paper, 53.1, p1094.
- [33] J-F. Li, et al, SID '99, International Symposium, Digest of Technical Paper, 51.4, p1066.
- [34] M. Kashihara, et al, SID '99, International Symposium, Digest of Technical Paper, 14.2, p158.
- [35] Exhibited by Plasmaco at "Display Show Case" in SID '99
- [36] W-C. Wang, et al, SID '99, International Symposium, Digest of Technical Paper, 37.2, p822.
- [37] D.L. Lee, et al, SID '99, International Symposium, Digest of Technical Paper, P-29, p580.
- [38] T.S. Fahlen, et al, SID '99, International Symposium, Digest of Technical Paper, 37.4L, p830.
- [39] N. Tiard-Gatel, et al, SID '99, International Symposium, Digest of Technical Paper, L2-2, p1138.
- [40] T. Shimoda, et al, SID '99, International Symposium, Digest of Technical Paper, 26.2, p372.
- [41] L.J. Hornberk, et al, SID '99, International Symposium, Digest of Technical Paper, Keynote Address.
- [42] W. Connell, et al, SID '99, International Symposium, Digest of Technical Paper, 46.2, p972.

(received July 27, 1999)