

DIGITAL MULTIFUNCTIONAL SYSTEM MX-B468F

User's Guide

April 2023

Machine type:

7020

Model:

4H6

Contents

- Safety information..... 6**
 - Conventions..... 6
 - Product statements..... 6

- Learn about the printer..... 9**
 - Printer configurations..... 9
 - Using the control panel..... 10
 - Understanding the status of the indicator light.....10
 - Selecting paper.....10

- Set up, install, and configure..... 17**
 - Selecting a location for the printer.....17
 - Attaching cables..... 18
 - Setting up and using the home screen applications..... 19
 - Setting up and using the accessibility features.....24
 - Setting up the printer to fax.....26
 - Configuring the e-mail SMTP settings..... 33
 - Loading paper and specialty media..... 41
 - Installing and updating software, drivers, and firmware..... 45
 - Installing hardware options.....47
 - Networking..... 71

- Secure the printer..... 74**
 - Locating the security slot..... 74
 - Erasing printer memory..... 74
 - Erasing printer storage drive..... 74
 - Restoring factory default settings..... 75
 - Statement of Volatility..... 75

- Print..... 76**
 - Printing from a computer..... 76
 - Printing from a mobile device..... 76
 - Printing from a flash drive..... 77
 - Supported flash drives and file types..... 78
 - Configuring confidential jobs..... 78

Printing confidential and other held jobs..... 79

Printing a font sample list.....80

Printing a directory list..... 80

Placing separator sheets between copies..... 80

Canceling a print job..... 80

Adjusting toner darkness..... 80

Copy..... 81

Using the automatic document feeder and scanner glass..... 81

Making copies..... 81

Copying photos.....81

Copying on letterhead..... 82

Copying on both sides of the paper..... 82

Reducing or enlarging copies..... 82

Collating copies..... 82

Placing separator sheets between copies..... 82

Copying multiple pages onto a single sheet..... 83

Copying cards..... 83

Creating a copy shortcut..... 83

E-mail.....84

Using the automatic document feeder and scanner glass..... 84

Sending an e-mail.....84

Creating an e-mail shortcut..... 84

Fax..... 85

Using the automatic document feeder and scanner glass..... 85

Sending a fax.....85

Scheduling a fax..... 86

Creating a fax destination shortcut..... 86

Changing the fax resolution..... 86

Adjusting the fax darkness.....87

Printing a fax log..... 87

Blocking junk faxes..... 87

Holding faxes..... 87

Forwarding a fax..... 87

Scan..... 89

- Using the automatic document feeder and scanner glass..... 89
- Scanning to a computer..... 89
- Scanning to an FTP server.....90
- Creating an FTP shortcut..... 90
- Scanning to a network folder.....90
- Creating a network folder shortcut.....91
- Scanning to a flash drive..... 91

Use printer menus..... 93

- Menu map.....93
- Device.....94
- Print..... 108
- Paper..... 116
- Copy..... 118
- Fax..... 122
- E-mail..... 137
- FTP..... 144
- USB Drive..... 148
- Network/Ports..... 153
- Security..... 166
- Reports..... 173
- Troubleshooting..... 175
- Forms Merge..... 175
- Printing the Menu Settings Page..... 176

Maintain the printer..... 177

- Checking the status of parts and supplies..... 177
- Configuring supply notifications..... 177
- Setting up e-mail alerts..... 177
- Viewing reports..... 178
- Ordering parts and supplies..... 178
- Replacing parts and supplies..... 179
- Cleaning printer parts..... 200
- Saving energy and paper..... 208
- Moving the printer to another location..... 208

Shipping the printer..... 209

Troubleshoot a problem..... 210

Print quality problems..... 210

Printing problems..... 211

The printer is not responding..... 237

Unable to read flash drive..... 238

Enabling the USB port..... 239

Clearing jams..... 239

Network connection problems..... 251

Hardware options problems..... 253

Issues with supplies..... 254

Paper feed problems..... 255

E-mailing problems..... 257

Faxing problems..... 258

Scanning problems..... 263

Contacting your dealer..... 270

Notices..... 271

Index..... 286

Safety information

Conventions

Note: A *note* identifies information that could help you.

Warning: A *warning* identifies something that could damage the product hardware or software.

CAUTION: A *caution* indicates a potentially hazardous situation that could injure you.

Different types of caution statements include:



CAUTION—POTENTIAL INJURY: Indicates a risk of injury.



CAUTION—SHOCK HAZARD: Indicates a risk of electrical shock.



CAUTION—HOT SURFACE: Indicates a risk of burn if touched.



CAUTION—TIPPING HAZARD: Indicates a crush hazard.



CAUTION—PINCH HAZARD: Indicates a risk of being caught between moving parts.

Product statements



CAUTION—POTENTIAL INJURY: To avoid the risk of fire or electrical shock, connect the power cord to an appropriately rated and properly grounded electrical outlet that is near the product and easily accessible.



CAUTION—POTENTIAL INJURY: To avoid the risk of fire or electrical shock, use only the power cord provided with this product or the manufacturer's authorized replacement.



CAUTION—POTENTIAL INJURY: Do not use this product with extension cords, multioutlet power strips, multioutlet extenders, or UPS devices. The power capacity of these types of accessories can be easily overloaded by a laser printer and may result in a risk of fire, property damage, or poor printer performance.



CAUTION—POTENTIAL INJURY: Do not use this product with an inline surge protector. The use of a surge protection device may result in a risk of fire, property damage, or poor printer performance.



CAUTION—POTENTIAL INJURY: To reduce the risk of fire, use only a 26 AWG or larger telecommunications (RJ-11) cord when connecting this product to the public switched telephone network. For users in Australia, the cord must be approved by the Australian Communications and Media Authority.





CAUTION—SHOCK HAZARD: To avoid the risk of electrical shock, do not place or use this product near water or wet locations.





CAUTION—SHOCK HAZARD: To avoid the risk of electrical shock, do not set up this product or make any electrical or cabling connections, such as the power cord, fax feature, or telephone, during a lightning storm.

 **CAUTION—POTENTIAL INJURY:** Do not cut, twist, bind, crush, or place heavy objects on the power cord. Do not subject the power cord to abrasion or stress. Do not pinch the power cord between objects such as furniture and walls. If any of these things happen, a risk of fire or electrical shock results. Inspect the power cord regularly for signs of such problems. Remove the power cord from the electrical outlet before inspecting it.

 **CAUTION—SHOCK HAZARD:** To avoid the risk of electrical shock, make sure that all external connections (such as Ethernet and telephone system connections) are properly installed in their marked plug-in ports.

 **CAUTION—SHOCK HAZARD:** To avoid the risk of electrical shock, if you are accessing the controller board or installing optional hardware or memory devices sometime after setting up the printer, then turn the printer off, and unplug the power cord from the electrical outlet before continuing. If you have any other devices attached to the printer, then turn them off as well, and unplug any cables going into the printer.

 **CAUTION—SHOCK HAZARD:** To avoid the risk of electrical shock, do not use the fax feature during a lightning storm.





 **CAUTION—SHOCK HAZARD:** To avoid the risk of electrical shock when cleaning the exterior of the printer, unplug the power cord from the electrical outlet and disconnect all cables from the printer before proceeding.

 **CAUTION—POTENTIAL INJURY:** If the printer weight is greater than 20 kg (44 lb), then it may require two or more people to lift it safely.

 **CAUTION—POTENTIAL INJURY:** When moving the printer, follow these guidelines to avoid personal injury or printer damage:

- Make sure that all doors and trays are closed.
- Turn off the printer, and then unplug the power cord from the electrical outlet.
- Disconnect all cords and cables from the printer.
- If the printer has separate floor-standing optional trays or output options attached to it, then disconnect them before moving the printer.
- If the printer has a caster base, then carefully roll it to the new location. Use caution when passing over thresholds and breaks in flooring.
- If the printer does not have a caster base but is configured with optional trays or output options, then remove the output options and lift the printer off the trays. Do not try to lift the printer and any options at the same time.
- Always use the handholds on the printer to lift it.
- Any cart used to move the printer must have a surface able to support the full footprint of the printer.
- Any cart used to move the hardware options must have a surface able to support the dimensions of the options.
- Keep the printer in an upright position.
- Avoid severe jarring movements.
- Make sure that your fingers are not under the printer when you set it down.
- Make sure that there is adequate clearance around the printer.

 **CAUTION—TIPPING HAZARD:** Installing one or more options on your printer or MFP may require a caster base, furniture, or other feature to prevent instability causing possible injury. For more information on supported configurations, contact the place where you purchased the printer.

-  **CAUTION—TIPPING HAZARD:** To reduce the risk of equipment instability, load each tray separately. Keep all other trays closed until needed.
-  **CAUTION—HOT SURFACE:** The inside of the printer might be hot. To reduce the risk of injury from a hot component, allow the surface to cool before touching it.
-  **CAUTION—PINCH HAZARD:** To avoid the risk of a pinch injury, use caution in areas marked with this label. Pinch injuries may occur around moving parts, such as gears, doors, trays, and covers.
-  **CAUTION—POTENTIAL INJURY:** This product uses a laser. Use of controls or adjustments or performance of procedures other than those specified in the *User's Guide* may result in hazardous radiation exposure.
-  **CAUTION—POTENTIAL INJURY:** The lithium battery in this product is not intended to be replaced. There is a danger of explosion if a lithium battery is incorrectly replaced. Do not recharge, disassemble, or incinerate a lithium battery. Discard used lithium batteries according to the manufacturer's instructions and local regulations.

This product is designed, tested, and approved to meet strict global safety standards with the use of specific manufacturer's components. The safety features of some parts may not always be obvious. The manufacturer is not responsible for the use of other replacement parts.

Refer service or repairs, other than those described in the user documentation, to a service representative.

SAVE THESE INSTRUCTIONS.

Learn about the printer

Printer configurations

CAUTION—TIPPING HAZARD: Installing one or more options on your printer or MFP may require a caster base, furniture, or other feature to prevent instability causing possible injury. For more information on supported configurations, contact the place where you purchased the printer.

CAUTION—TIPPING HAZARD: To reduce the risk of equipment instability, load each tray separately. Keep all other trays closed until needed.

You can configure your printer by adding up to three optional 250- or 550-sheet trays. For more information, see [“Installing optional trays” on page 48](#).

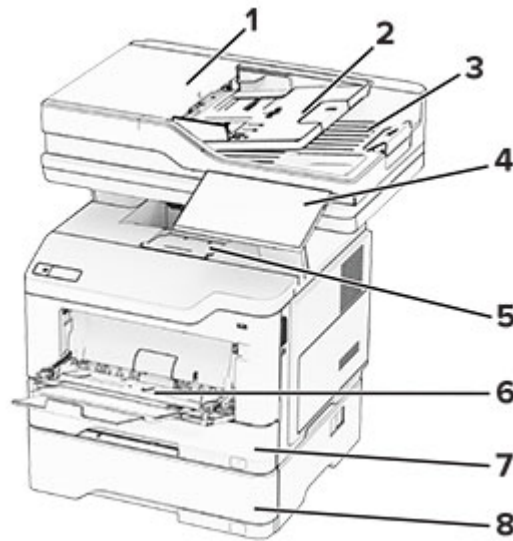

| | |
|---|---------------------------------|
| 1 | Automatic document feeder (ADF) |
| 2 | ADF tray |
| 3 | ADF bin |
| 4 | Control panel |
| 5 | Standard bin |
| 6 | Multipurpose feeder |
| 7 | Standard 550-sheet tray |
| 8 | Optional 250- or 550-sheet tray |

Using the control panel

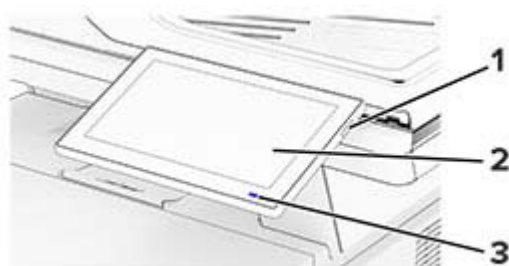

| | Control panel part | Function |
|---|--------------------|---|
| 1 | Power button | <ul style="list-style-type: none"> Turn on or turn off the printer. Note: To turn off the printer, press and hold the power button for five seconds. Set the printer to Sleep mode. Wake the printer from Sleep or Hibernate mode. |
| 2 | Display | <ul style="list-style-type: none"> View the printer messages and supply status. Set up and operate the printer. |
| 3 | Indicator light | Check the status of the printer. |

Understanding the status of the indicator light

| Indicator light | Printer status |
|-----------------|---|
| Off | The printer is off. |
| Solid blue | The printer is ready. |
| Blinking blue | The printer is printing or processing data. |
| Blinking red | The printer requires user intervention. |
| Solid amber | The printer is in Sleep mode. |
| Blinking amber | The printer is in Deep Sleep or Hibernate mode. |

Selecting paper

Paper guidelines

Use the appropriate paper to prevent jams and help ensure trouble-free printing.

- Always use new, undamaged paper.
- Before loading paper, know the recommended printable side of the paper. This information is usually indicated on the paper package.
- Do not use paper that has been cut or trimmed by hand.

- Do not mix paper sizes, types, or weights in the same tray; mixing results in jams.
- Do not use coated papers unless they are specifically designed for electrophotographic printing.

Paper characteristics

The following paper characteristics affect print quality and reliability. Consider these factors before printing on them.

Weight

Trays can feed paper of varying weights. Paper lighter than 60 g/m² (16 lb) may not be stiff enough to feed properly, and may cause jams. For more information, see the “Supported paper weights” topic.

Curl

Curl is the tendency for paper to curl at its edges. Excessive curl can cause paper feeding problems. Curl can occur after the paper passes through the printer, where it is exposed to high temperatures. Storing paper unwrapped in hot, humid, cold, or dry conditions can contribute to paper curling before printing and can cause feeding problems.

Smoothness

Paper smoothness directly affects print quality. If paper is too rough, toner cannot fuse to it properly. If paper is too smooth, it can cause paper feeding or print quality issues. We recommend the use of paper with 50 Sheffield points.

Moisture content

The amount of moisture in paper affects both print quality and the printer ability to feed the paper correctly. Leave paper in its original wrapper until you use it. Exposure of paper to moisture changes can degrade its performance.

Before printing, store paper in its original wrapper for 24 to 48 hours. The environment in which the paper is stored must be the same as the printer. Extend the time several days if the storage or transportation environment is very different from the printer environment. Thick paper may also require a longer conditioning period.

Grain direction

Grain refers to the alignment of the paper fibers in a sheet of paper. Grain is either *grain long* which runs the length of the paper, or *grain short* which runs the width of the paper. For recommended grain direction, see the “Supported paper weights” topic.

Fiber content

Most high-quality xerographic paper is made from 100 percent chemically treated pulped wood. This content provides the paper with a high degree of stability, resulting in fewer paper feeding problems and better print quality. Paper containing fibers such as cotton can negatively affect paper handling.

Unacceptable paper

The following paper types are not recommended for use with the printer:

- Chemically treated papers that are used to make copies without carbon paper. They are also known as carbonless papers, carbonless copy paper (CCP), or no carbon required (NCR) paper.
- Preprinted papers with chemicals that may contaminate the printer.
- Preprinted papers that can be affected by the temperature in the printer fuser.
- Preprinted papers that require a registration (the precise print location on the page) greater than ± 2.3 mm (± 0.09 in.). For example, optical character recognition (OCR) forms.

Sometimes, registration can be adjusted with a software app to print successfully on these forms.

- Coated papers (erasable bond), synthetic papers, or thermal papers.
- Rough-edged, rough or heavily textured surface papers, or curled papers.
- Recycled papers that fail EN12281:2002 (European).
- Paper weighing less than 60 g/m² (16 lb).
- Multiple-part forms or documents.

Storing paper

Use these paper storage guidelines to help avoid jams and uneven print quality:

- Store paper in its original wrapper in the same environment as the printer for 24 to 48 hours before printing.
- Extend the time several days if the storage or transportation environment is very different from the printer environment. Thick paper may also require a longer conditioning period.
- For best results, store paper where the temperature is 21°C (70°F) and the relative humidity is 40 percent.
- Most label manufacturers recommend printing in a temperature range of 18–24°C (65–75°F) with relative humidity between 40 and 60 percent.
- Store paper in cartons, on a pallet or shelf, rather than on the floor.
- Store individual packages on a flat surface.
- Do not store anything on top of individual paper packages.
- Take paper out of the carton or wrapper only when you are ready to load it in the printer. The carton and wrapper help keep the paper clean, dry, and flat.

Selecting preprinted forms and letterhead

- Use grain long paper.
- Use only forms and letterhead printed using an offset lithographic or engraved printing process.
- Avoid paper with rough or heavily textured surfaces.
- Use inks that are not affected by the resin in toner. Inks that are oxidation-set or oil-based generally meet these requirements; latex inks might not.
- Print samples on preprinted forms and letterheads considered for use before buying large quantities. This action determines whether the ink in the preprinted form or letterhead affects print quality.
- When in doubt, contact your paper supplier.
- When printing on letterhead, load the paper in the proper orientation for your printer.

Supported paper sizes

| Paper size | Standard 550-sheet tray | Optional 250- or 550-sheet tray | Multipurpose feeder | Two-sided printing | Scanner glass | Automatic document feeder |
|--|-------------------------|---------------------------------|---------------------|--------------------|---------------|---------------------------|
| A4 210 x 297 mm (8.27 x 11.7 in.) | ✓ | ✓ | ✓ | ✓ | ✓ | ✓ |
| A5 Portrait (SEF) 148 x 210 mm (5.83 x 8.27 in.) | ✓ | ✓ | ✓ | X | ✓ | ✓ |
| A5 Landscape (LEF)¹ 210 x 148 mm (8.27 x 5.83 in.) | ✓ | X | ✓ | X | ✓ | ✓ |
| A6 105 x 148 mm (4.13 x 5.83 in.) | ✓ | X | ✓ | X | ✓ | ✓ |
| JIS B5 182 x 257 mm (7.17 x 10.1 in.) | ✓ | ✓ | ✓ | X | ✓ | ✓ |
| Oficio (Mexico) 216 x 340 mm (8.5 x 13.4 in.) | ✓ | ✓ | ✓ | ✓ | ✓ | ✓ |
| Hagaki 100 x 148 mm (3.93 x 5.83 in.) | X | X | ✓ | X | ✓ | X |
| Statement 139.7 x 215.9 mm (5.5 x 8.5 in.) | ✓ | ✓ | ✓ | X | ✓ | ✓ |
| Executive 184.2 x 266.7 mm (7.25 x 10.5 in.) | ✓ | ✓ | ✓ | X | ✓ | ✓ |
| Letter 215.9 x 279.4 mm (8.5 x 11 in.) | ✓ | ✓ | ✓ | ✓ | ✓ | ✓ |

¹ The default support is short-edge feed.

² When Universal is selected, the page is formatted for 215.90 x 355.60 mm (8.5 x 14 in.) unless specified by the application.

³ Paper must at least be 210 mm (8.27 in.) wide and 279.4 mm (11 in.) long for two-sided printing.

| Paper size | Standard 550-sheet tray | Optional 250- or 550-sheet tray | Multipurpose feeder | Two-sided printing | Scanner glass | Automatic document feeder |
|---|-------------------------|---------------------------------|---------------------|--------------------|---------------|---------------------------|
| Legal 215.9 x 355.6 mm (8.5 x 14 in.) | ✓ | ✓ | ✓ | ✓ | ✓ | ✓ |
| Folio 215.9 x 330.2 mm (8.5 x 13 in.) | ✓ | ✓ | ✓ | ✓ | ✓ | ✓ |
| Universal² 105 x 148 mm to 215.9 x 359.92 mm (4.13 x 5.83 in. to 8.5 x 14.17 in.) | ✓ | ✓ | X | ✓ ³ | X | ✓ |
| Universal² 76.2 x 127 mm to 215.9 x 359.92 mm (3 x 5.83 in. to 8.5 x 14.17 in.) | X | X | ✓ | X | X | X |
| Universal² 25.4 x 25.4 mm to 215.9 x 355.6 mm (1 x 1 in. to 8.5 x 14 in.) | X | X | X | X | ✓ | X |
| 7 3/4 Envelope 98.4 x 190.5 mm (3.875 x 7.5 in.) | X | X | ✓ | X | ✓ | X |
| 9 Envelope 98.4 x 225.4 mm (3.875 x 8.9 in.) | X | X | ✓ | X | ✓ | X |
| 10 Envelope 104.8 x 241.3 mm (4.12 x 9.5 in.) | X | X | ✓ | X | ✓ | X |
| DL Envelope 110 x 220 mm (4.33 x 8.66 in.) | X | X | ✓ | X | ✓ | X |
| C5 Envelope 162 x 229 mm (6.38 x 9.01 in.) | X | X | ✓ | X | ✓ | X |

¹ The default support is short-edge feed.

² When Universal is selected, the page is formatted for 215.90 x 355.60 mm (8.5 x 14 in.) unless specified by the application.

³ Paper must at least be 210 mm (8.27 in.) wide and 279.4 mm (11 in.) long for two-sided printing.

| Paper size | Standard 550-sheet tray | Optional 250- or 550-sheet tray | Multipurpose feeder | Two-sided printing | Scanner glass | Automatic document feeder |
|--|-------------------------|---------------------------------|---------------------|--------------------|---------------|---------------------------|
| B5 Envelope 176 x 250 mm (6.93 x 9.84 in.) | X | X | ✓ | X | ✓ | X |
| Other Envelope 76.2 x 127 mm to 215.9 x 359.92 mm (3 x 5.83 in. to 8.5 x 14.17 in.) | X | X | ✓ | X | ✓ | X |

¹ The default support is short-edge feed.

² When Universal is selected, the page is formatted for 215.90 x 355.60 mm (8.5 x 14 in.) unless specified by the application.

³ Paper must at least be 210 mm (8.27 in.) wide and 279.4 mm (11 in.) long for two-sided printing.

Supported paper types

| Paper type | Standard 550-sheet tray | Optional 250- or 550-sheet tray | Multipurpose feeder | Two-sided printing | Automatic document feeder |
|-----------------------|-------------------------|---------------------------------|---------------------|--------------------|---------------------------|
| Plain paper | ✓ | ✓ | ✓ | ✓ | ✓ |
| Card stock | X | X | ✓ | X | X |
| Recycled | ✓ | ✓ | ✓ | ✓ | ✓ |
| Paper labels* | ✓ | ✓ | ✓ | X | X |
| Bond | ✓ | ✓ | ✓ | ✓ | ✓ |
| Letterhead | ✓ | ✓ | ✓ | ✓ | ✓ |
| Preprinted | ✓ | ✓ | ✓ | ✓ | ✓ |
| Colored Paper | ✓ | ✓ | ✓ | ✓ | ✓ |
| Light Paper | ✓ | ✓ | ✓ | ✓ | ✓ |
| Heavy Paper | ✓ | ✓ | ✓ | ✓ | ✓ |
| Rough/Cotton | ✓ | ✓ | ✓ | ✓ | ✓ |
| Envelope | X | X | ✓ | X | X |
| Rough envelope | X | X | ✓ | X | X |

* One-sided paper labels are supported for occasional use of less than 20 pages per month. Vinyl, pharmacy, or two-sided labels are not supported.

Supported paper weights

| Standard 550-sheet tray | Optional 250- or 550-sheet tray | Multipurpose feeder | Two-sided printing* | Automatic document feeder |
|--|--|--|---|--|
| 60–120 g/m ² (16–32 lb bond) | 60–120 g/m ² (16–32 lb bond) | 60–216 g/m ² (16–58 lb bond) | 60–90 g/m ² (16–24 lb bond) | 52–120 g/m ² (14–32 lb bond) |
| * Does not support card stock, labels, or envelopes. | | | | |

Set up, install, and configure

Selecting a location for the printer

- Leave enough room to open trays, covers, and doors and to install hardware options.
- Set up the printer near an electrical outlet.

⚠ CAUTION—POTENTIAL INJURY: To avoid the risk of fire or electrical shock, connect the power cord to an appropriately rated and properly grounded electrical outlet that is near the product and easily accessible.

⚡ CAUTION—SHOCK HAZARD: To avoid the risk of electrical shock, do not place or use this product near water or wet locations.

- Make sure that airflow in the room meets the latest revision of the ASHRAE 62 standard or the CEN Technical Committee 156 standard.
- Provide a flat, sturdy, and stable surface.
- Keep the printer:
 - Clean, dry, and free of dust.
 - Away from stray staples and paper clips.
 - Away from the direct airflow of air conditioners, heaters, or ventilators.
 - Free from direct sunlight and humidity extremes.
- Observe the recommended temperatures and avoid fluctuations:

| | |
|---------------------|-----------------------------|
| Ambient temperature | 10 to 32.2°C (50 to 90°F) |
| Storage temperature | 15.6 to 32.2°C (60 to 90°F) |

- Allow the following recommended amount of space around the printer for proper ventilation:

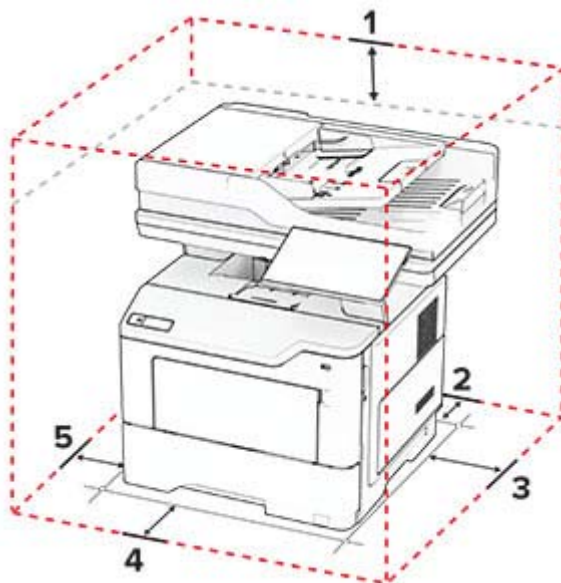

| | | |
|----------|------|-------------------|
| 1 | Top | 305 mm (12 in.) |
| 2 | Rear | 100 mm (3.94 in.) |

| | | |
|----------|------------|--|
| 3 | Right side | 76.2 mm (3 in.) |
| 4 | Front | 305 mm (12 in.) Note: The minimum space needed in front of the printer is 76 mm (3 in.). |
| 5 | Left side | 110 mm (4.33 in.) |

Attaching cables

- ⚠ CAUTION—SHOCK HAZARD:** To avoid the risk of electrical shock, do not set up this product or make any electrical or cabling connections, such as the power cord, fax feature, or telephone, during a lightning storm.
- ⚠ CAUTION—POTENTIAL INJURY:** To avoid the risk of fire or electrical shock, connect the power cord to an appropriately rated and properly grounded electrical outlet that is near the product and easily accessible.
- ⚠ CAUTION—POTENTIAL INJURY:** To avoid the risk of fire or electrical shock, use only the power cord provided with this product or the manufacturer's authorized replacement.
- ⚠ CAUTION—POTENTIAL INJURY:** To reduce the risk of fire, use only a 26 AWG or larger telecommunications (RJ-11) cord when connecting this product to the public switched telephone network. For users in Australia, the cord must be approved by the Australian Communications and Media Authority.

Warning—Potential Damage: To avoid loss of data or printer malfunction, do not touch the USB cable, any wireless network adapter, or the printer in the areas shown while actively printing.

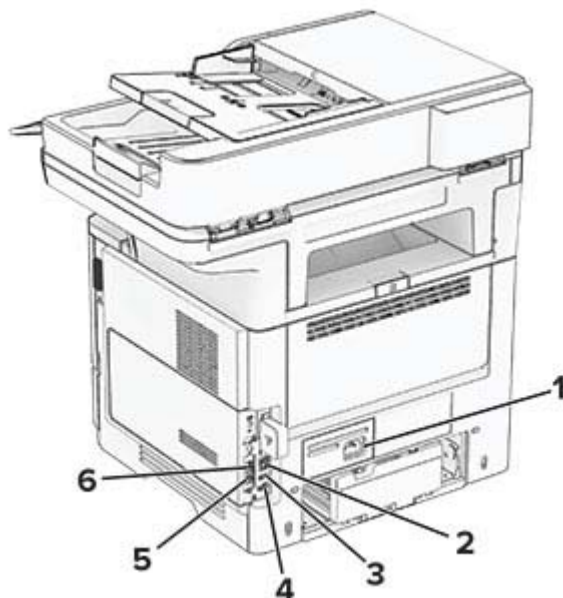

| | Printer port | Function |
|----------|-------------------|---|
| 1 | Power cord socket | Connect the printer to a properly grounded electrical outlet. |
| 2 | Ethernet port | Connect the printer to a network. |
| 3 | USB port | Attach a keyboard or any compatible option. |

| | Printer port | Function |
|---|------------------|--|
| 4 | USB printer port | Connect the printer to a computer. |
| 5 | EXT port | Connect more devices (telephone or answering machine) to the printer and the telephone line. Use this port if you do not have a dedicated fax line for the printer and if this connection method is supported in your country or region. |
| 6 | LINE port | Connect the printer to an active telephone line through a standard wall jack (RJ-11), DSL filter, or VoIP adapter, or any other adapter that allows you to access the telephone line to send and receive faxes. |

Setting up and using the home screen applications

Using the home screen

Note: Your home screen may vary depending on your home screen customization settings, administrative setup, and active embedded solutions.



| # | Icon | Function |
|---|-----------------------|---|
| 1 | Stop or Cancel button | Stop the current job. |
| 2 | Copy | Make copies. |
| 3 | Change Language | Change the language on the printer display. |
| 4 | E-mail | Send e-mails. |
| 5 | Settings | Access the printer menus. |
| 6 | Fax | Send fax. |
| 7 | Address Book | Access, create, and organize contacts. |

| # | Icon | Function |
|----|------------------|---|
| 8 | Status/Supplies | <ul style="list-style-type: none"> Show a printer warning or error message whenever the printer requires intervention to continue processing. View more information on the printer warning or message, and on how to clear it. <p>Note: You can also access this setting by touching the top section of the home screen.</p> |
| 9 | Held Jobs | Show all the current held print jobs |
| 10 | Job Queue | Show all the current print jobs. Note: You can also access this setting by touching the top section of the home screen. |
| 11 | USB Drive | View, select, or print photos and documents from a flash drive. |
| 12 | Scan Profiles | Scan and save documents directly to the computer. |
| 13 | FTP | Scan and save documents directly to an FTP server. |
| 14 | Bookmarks | Organize all bookmarks. |
| 15 | Hard Disk | View, select, and manage documents from a hard drive or an intelligent storage drive. |
| 16 | Network Folder | Scan to a network folder or network location. |
| 17 | Start button | Start a job, depending on which mode is selected. |
| 18 | On-screen keypad | Enter numbers or symbols in an input field. |

Customizing the home screen

1 Open a web browser, and then type the printer IP address in the address field.

Notes:

- View the printer IP address on the printer home screen. The IP address appears as four sets of numbers separated by periods, such as 123.123.123.123.
- If you are using a proxy server, then temporarily disable it to load the web page correctly.

2 Click **Settings > Device > Home Screen Customization**.

3 Do one or more of the following:

- To add an icon to the home screen, click **+**, select the app name, and then click **Add**.
- To remove a home screen icon, select the app name, and then click **Remove**.
- To customize an app name, select the app name, click **Edit**, and then assign a name.
- To restore the name of an app, select the app name, click **Edit**, and then select **Restore app label**.
- To add a space between apps, click **+**, select **BLANK SPACE**, and then click **Add**.
- To arrange the apps, drag the app names in the order that you want.
- To restore the default home screen, click **Restore home screen**.

4 Apply the changes.

Setting up Scan Center

- 1 From the home screen, touch **Scan Center**.
- 2 Select and create a destination, and then configure the settings.

Notes:

- When creating a network destination, make sure to validate and adjust the settings until no errors occur.
- Only destinations created from the Embedded Web Server are saved. For more information, see the documentation that came with the solution.

- 3 Apply the changes.

Creating a shortcut

- 1 From the home screen, touch **Shortcut Center**.

Note: The icon and name may have been changed. For more information, contact your administrator.

- 2 Select a printer function, and then touch **Create Shortcut**.

Note: The Secure E-mail function is not supported.

- 3 Configure the settings, and then touch **Save**.

- 4 Type a unique shortcut name.

Note: To avoid clipped names on the home screen, type only up to 25 characters.

- 5 Touch **OK**.

The application automatically generates a unique shortcut number.

Note: To launch the shortcut, touch , touch #, and then enter the shortcut number.

Setting up Card Copy

- 1 Open a web browser, and then type the printer IP address in the address field.

Notes:

- View the printer IP address on the printer home screen. The IP address appears as four sets of numbers separated by periods, such as 123.123.123.123.
- If you are using a proxy server, then temporarily disable it to load the web page correctly.

- 2 Click **Apps > Card Copy > Configure**.

Notes:

- Make sure that Display Icon is enabled.
- Make sure that E-mail Settings and Network Share Settings are configured.
- When scanning a card, make sure that the scan resolution does not exceed 200 dpi for color and 400 dpi for black and white.
- When scanning multiple cards, make sure that the scan resolution does not exceed 150 dpi for color and 300 dpi for black and white.

3 Apply the changes.

Note: You need a printer hard disk or an intelligent storage drive to scan multiple cards.

Using Display Customization

Before using the application, make sure to enable and configure the screen saver, slideshow, and wallpaper settings from the Embedded Web Server.

Managing screen saver and slide show images

1 From the Embedded Web Server, click **Apps > Display Customization > Configure**.

2 In the Screen Saver and Slideshow Images section, add, edit, or delete an image.

Notes:

- You can add up to 10 images.
- When enabled, the status icons appear on the screen saver only when there are errors, warnings, or cloud-based notifications.

3 Apply the changes.

Changing the wallpaper image

1 From the home screen, touch **Change Wallpaper**.

2 Select an image to use.

3 Apply the changes.

Running a slide show from a flash drive

1 Insert a flash drive into the front USB port.

2 From the home screen, touch **Slideshow**.

Note: You can remove the flash drive after the slide show starts, but the images are not stored in the printer. If the slide show stops, then insert the flash drive again to view the images.

Managing bookmarks

Creating bookmarks

Use bookmarks to print frequently accessed documents that are stored in servers or on the web.

1 Open a web browser, and then type the printer IP address in the address field.

Notes:

- View the printer IP address on the printer home screen. The IP address appears as four sets of numbers separated by periods, such as 123.123.123.123.
- If you are using a proxy server, then temporarily disable it to load the web page correctly.

2 Click **Bookmarks > Add Bookmark**, and then type a bookmark name.

- 3 Select an Address protocol type, and then do one of the following:
 - For HTTP and HTTPS, type the URL that you want to bookmark.
 - For HTTPS, make sure to use the host name instead of the IP address. For example, type **myWebsite.com/sample.pdf** instead of typing **123.123.123.123/sample.pdf**. Make sure that the host name also matches the Common Name (CN) value in the server certificate. For more information on obtaining the CN value in the server certificate, see the help information for your web browser.
 - For FTP, type the FTP address. For example, **myServer/myDirectory**. Enter the FTP port. Port 21 is the default port for sending commands.
 - For SMB, type the network folder address. For example, **myServer/myShare/myFile.pdf**. Type the network domain name.
 - If necessary, select the Authentication type for FTP and SMB.

To limit access to the bookmark, enter a PIN.

Note: The application supports the following file types: PDF, JPEG, TIFF, and HTML-based web pages. Other file types such as DOCX and XLXS are supported in some printer models.

- 4 Click **Save**.

Creating folders

- 1 Open a web browser, and then type the printer IP address in the address field.

Notes:

- View the printer IP address on the printer home screen. The IP address appears as four sets of numbers separated by periods, such as 123.123.123.123.
- If you are using a proxy server, then temporarily disable it to load the web page correctly.





- 2 Click **Bookmarks > Add Folder**, and then type a folder name.

Note: To limit access to the folder, enter a PIN.

- 3 Click **Save**.

Note: You can create folders or bookmarks inside a folder. To create a bookmark, see [“Creating bookmarks” on page 22](#).

Managing contacts

- 1 From the home screen, touch **Address Book**.
- 2 Do one or more of the following:
 - To add a contact, touch  on top of the screen, and then touch **Create Contact**. If necessary, specify a login method to allow application access.
 - To delete a contact, touch  on top of the screen, touch **Delete Contacts**, and then select the contact.
 - To edit contact information, touch the contact name.
 - To create a group, touch  on top of the screen, and then touch **Create Group**. If necessary, specify a login method to allow application access.
 - To delete a group, touch  on top of the screen, touch **Delete Groups**, and then select the group.
 - To edit a contact group, touch **GROUPS >** select a group name >  > select the action you want to make.
- 3 Apply the changes.

Setting up and using the accessibility features

Activating Voice Guidance

From the home screen

- 1 In one motion and using one finger, slowly swipe left then up on the display until you hear a voice message.

Note: For printer models without built-in speakers, use headphones to hear the message.

- 2 Using two fingers, touch **OK**.

Note: If the gesture does not work, then apply more pressure.

From the keyboard

- 1 Press and hold the **5** key until you hear a voice message.

Note: For printer models without built-in speakers, use headphones to hear the message.

- 2 Press **Tab** to navigate the focus cursor to the OK button, and then press **Enter**.

Notes:

- When Voice Guidance is activated, always use two fingers to select any item on the display.
- Voice Guidance has limited language support.

Deactivating Voice Guidance

- 1 In one motion and using one finger, slowly swipe left then up on the display until you hear a voice message.

Note: For printer models without built-in speakers, use headphones to hear the message.

- 2 Using two fingers, do either of the following:

- Touch **Voice Guidance**, then touch **OK**.
- Touch **Cancel**.

Note: If the gesture does not work, then apply more pressure.

You can also deactivate Voice Guidance by doing either of the following:

- Using two fingers, double tap the home screen.
- Press the power button to put the printer in Sleep or Hibernate mode.

Navigating the screen using gestures

Notes:

- Most of the gestures are applicable only when Voice Guidance is activated.
- Enable Magnification to use the zoom and pan gestures.
- Use a physical keyboard to type characters and adjust certain settings.

| Gesture | Function |
|--|---|
| Swipe left then up using one finger | Launch Accessibility mode. Use the same gesture to exit Accessibility mode. Note: This gesture is also applicable when the printer is in normal mode. |
| Double-tap using one finger | Select an option or item on the screen. |
| Double-tap the home icon using two fingers | Deactivate the Accessibility mode. |
| Triple-tap using one finger | Zoom in or zoom out text and images. |
| Swipe right or swipe down using one finger | Move to the next item on the screen. |
| Swipe left or swipe up using one finger | Move to the previous item on the screen. |
| Swipe up then down using one finger | Move to the first item on the screen. |
| Pan | Access parts of the zoomed image that are beyond the limit of the screen. Note: Use two fingers to drag a zoomed image. |
| Swipe up then right using one finger | Increase the volume. Note: This gesture is also applicable when the printer is in normal mode. |
| Swipe down then right using one finger | Decrease the volume. Note: This gesture is also applicable when the printer is in normal mode. |
| Swipe up then left using one finger | Exit an application and return to the home screen. |
| Swipe down then left using one finger | Go back to the previous setting. |

Using the on-screen keyboard

When the on-screen keyboard appears, do one or more of the following:

- Touch a key to announce and type the character in the field.
- Drag a finger across different characters to announce and type the character in the field.
- Touch a text box using two fingers to announce the characters in the field.
- Touch **Backspace** to delete characters.

Enabling Magnification mode

- 1 In one motion and using one finger, slowly swipe left then up on the display until you hear a voice message.

Note: For printer models without built-in speakers, use headphones to hear the message.

- 2 Using two fingers, do the following:

- a Touch **Magnification mode**.
- b Touch **OK**.

Note: If the gesture does not work, then apply more pressure.

For more information on navigating a magnified screen, see [“Navigating the screen using gestures” on page 24](#).

Adjusting the Voice Guidance speech rate

- 1 From the home screen, touch **Settings > Device > Accessibility > Speech Rate**.
- 2 Select the speech rate.

Adjusting the default headphone volume

- 1 From the home screen, touch **Settings > Device > Accessibility**.
- 2 Adjust the headphone volume.

Note: The volume resets to the default value after the user exits Accessibility mode or when the printer wakes from Sleep or Hibernate mode.

Adjusting the default internal speaker volume

- 1 From the home screen, touch .
- 2 Adjust the volume.

Notes:

- If Quiet Mode is enabled, then audible alerts are turned off. This setting also slows the printer performance.
- The volume resets to the default value after the user exits Accessibility mode or when the printer wakes from Sleep or Hibernate mode.

Enabling spoken passwords or personal identification numbers

- 1 From the home screen, touch **Settings > Device > Accessibility > Speak Passwords/PINs**.
- 2 Enable the setting.

Setting up the printer to fax

Setting up the fax function using analog fax

Notes:

- Some connection methods are applicable only in some countries or regions.
- If the fax function is enabled and not fully set up, then the indicator light may blink red.
- If you do not have a TCP/IP environment, then use the control panel to set up fax.

Warning—Potential Damage: To avoid loss of data or printer malfunction, do not touch cables or the printer in the area shown while actively sending or receiving a fax.



Using the control panel

- 1 From the home screen, touch **Settings > Fax > Fax Setup > General Fax Settings**.
- 2 Configure the settings.

Using the Embedded Web Server

- 1 Open a web browser, and then type the printer IP address in the address field.

Notes:

- View the printer IP address on the home screen. The IP address appears as four sets of numbers separated by periods, such as 123.123.123.123.
- If you are using a proxy server, then temporarily disable it to load the web page correctly.

- 2 Click **Settings > Fax > Fax Setup > General Fax Settings**.
- 3 Configure the settings.
- 4 Apply the changes.

Setting up the fax function using fax server

Notes:

- This feature lets you send fax messages to a fax service provider that supports e-mail receiving.
- This feature supports outgoing fax messages only. To support fax receive, make sure that you have a device-based fax, such as analog fax or Fax over IP (FoIP), configured in your printer.

- 1 Open a web browser, and then type the printer IP address in the address field.

Notes:

- View the printer IP address on the home screen. The IP address appears as four sets of numbers separated by periods, such as 123.123.123.123.

- If you are using a proxy server, then temporarily disable it to load the web page correctly.

2 Click **Settings > Fax**.

3 From the Fax Mode menu, select **Fax Server**, and then click **Save**.

4 Click **Fax Server Setup**.

5 In the To Format field, type **[#]@myfax.com**, where **[#]** is the fax number and **myfax.com** is the fax provider domain.

Notes:

- If necessary, configure the Reply Address, Subject, or Message fields.
- To let the printer receive fax messages, enable the device-based fax receive setting. Make sure that you have a device-based fax configured.

6 Click **Save**.

7 Click **Fax Server E-mail Settings**, and then do either of the following:

- Enable **Use E-mail SMTP Server**.

Note: If the E-mail SMTP settings are not configured, then see [“Configuring the e-mail SMTP settings” on page 33](#).

- Configure the SMTP settings. For more information, contact your e-mail service provider.

8 Apply the changes.

Setting up fax using a standard telephone line

Note: These instructions apply only to printers that support analog fax.



CAUTION—SHOCK HAZARD: To avoid the risk of electrical shock, do not set up this product or make any electrical or cabling connections, such as the power cord, fax feature, or telephone, during a lightning storm.



CAUTION—SHOCK HAZARD: To avoid the risk of electrical shock, do not use the fax feature during a lightning storm.



CAUTION—POTENTIAL INJURY: To reduce the risk of fire, use only a 26 AWG or larger telecommunications (RJ-11) cord when connecting this product to the public switched telephone network. For users in Australia, the cord must be approved by the Australian Communications and Media Authority.

Setup 1: Printer is connected to a dedicated fax line

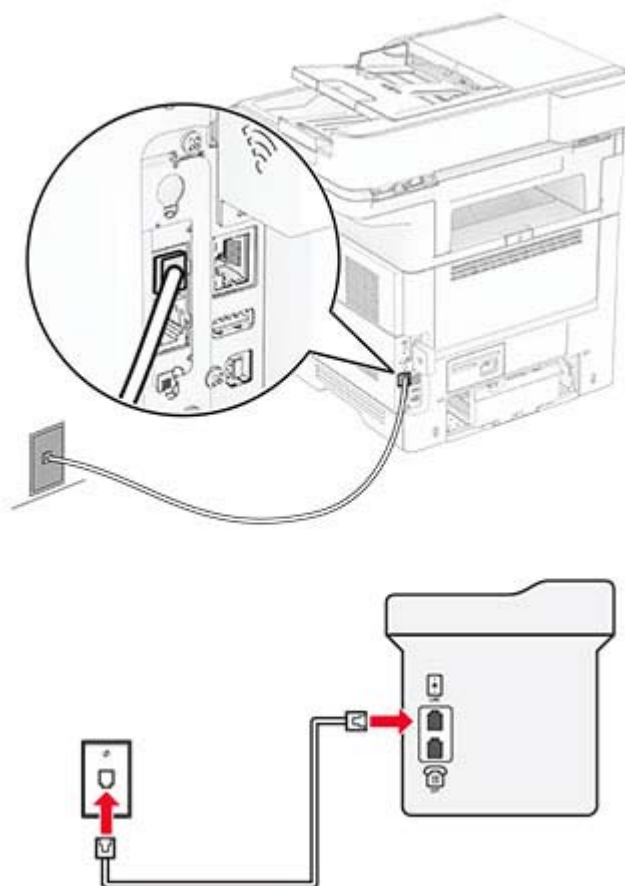

- 1 Connect one end of the telephone cable to the line port of the printer.
- 2 Connect the other end of the cable to an active analog wall jack.

Notes:

- You can set the printer to receive faxes automatically (set Auto Answer to **On**) or manually (set Auto Answer to **Off**).
- If you want to receive faxes automatically, then set the printer to pick up on a specified number of rings.

Setup 2: Printer is sharing the line with an answering machine

Note: If you subscribe to a distinctive ring service, then make sure that you set the correct ring pattern for the printer. Otherwise, the printer does not receive faxes even if you have set it to receive faxes automatically.

Connected to different wall jacks

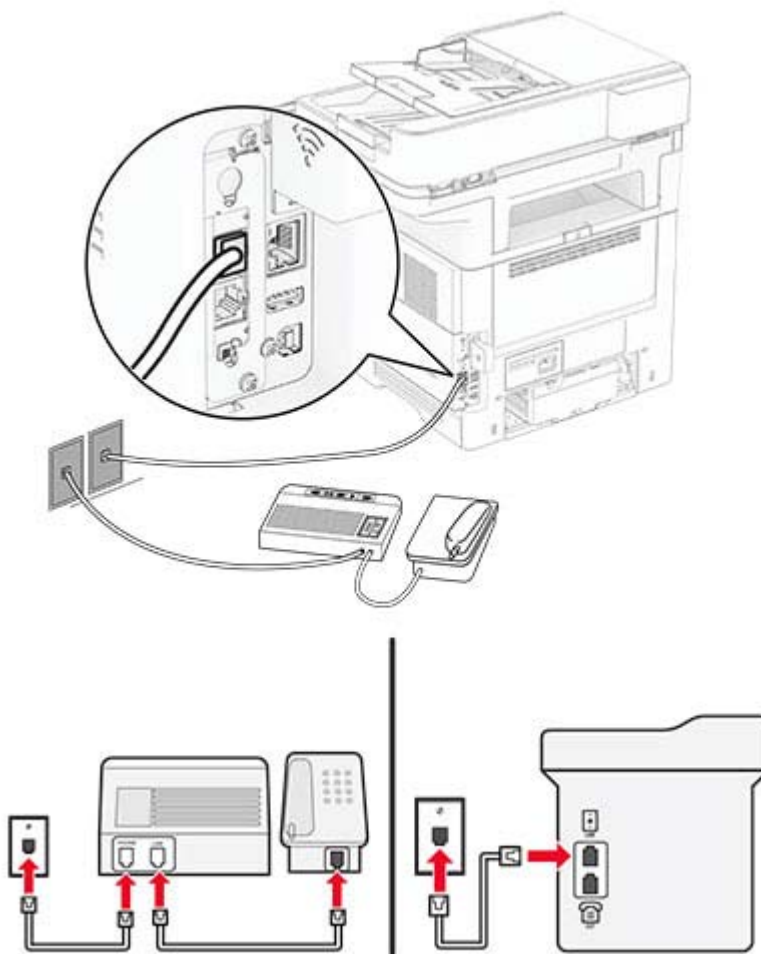

- 1 Connect one end of the telephone cable to the line port of the printer.
- 2 Connect the other end of the cable to an active analog wall jack.

Notes:

- If you have only one telephone number on your line, then set the printer to receive faxes automatically.
- Set the printer to pick up calls two rings after the answering machine. For example, if the answering machine picks up calls after four rings, then set the printer Rings to Answer setting to **6**.

Setting up fax in countries or regions with different telephone wall jacks and plugs

Note: These instructions apply only to printers that support analog fax.

⚠ CAUTION—SHOCK HAZARD: To avoid the risk of electrical shock, do not set up this product or make any electrical or cabling connections, such as the power cord, fax feature, or telephone, during a lightning storm.

 **CAUTION—SHOCK HAZARD:** To avoid the risk of electrical shock, do not use the fax feature during a lightning storm.

 **CAUTION—POTENTIAL INJURY:** To reduce the risk of fire, use only a 26 AWG or larger telecommunications (RJ-11) cord when connecting this product to the public switched telephone network. For users in Australia, the cord must be approved by the Australian Communications and Media Authority.

The standard wall jack adopted by most countries or regions is RJ-11. If the wall jack or equipment in your facility is not compatible with this type of connection, then use a telephone adapter. An adapter for your country or region may not come with your printer, and you may need to purchase it separately.

There may be an adapter plug installed in the telephone port of the printer. Do not remove the adapter plug from the telephone port of the printer if you are connecting to a serial or cascaded telephone system.

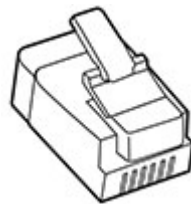

Connecting the printer to a non-RJ-11 wall jack

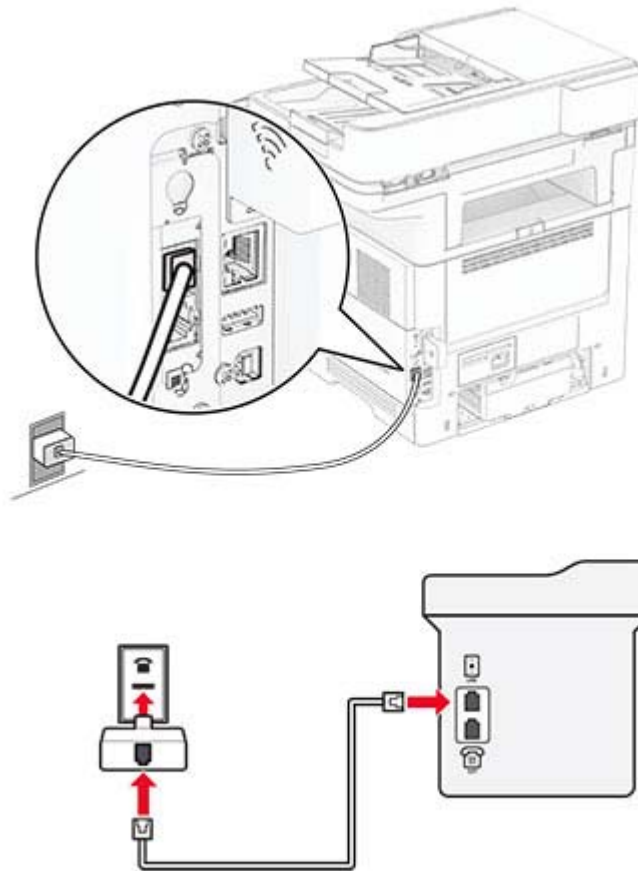

- 1 Connect one end of the telephone cable to the line port of the printer.
- 2 Connect the other end of the cable to the RJ-11 adapter, and then connect the adapter to the wall jack.
- 3 If you want to connect another device with a non-RJ-11 connector to the same wall jack, then connect it directly to the telephone adapter.

Connecting to a distinctive ring service

A distinctive ring service lets you have multiple telephone numbers on one telephone line. Each telephone number is assigned a different ring pattern.

Note: These instructions apply only to printers that support analog fax.

- 1 From the home screen, touch **Settings > Fax > Fax Setup > Fax Receive Settings > Admin Controls > Answer On**.
- 2 Select a ring pattern.

Setting the fax date and time

Note: Make sure that fax is configured. For more information, see the [Setting up the printer to fax](#) section.

- 1 From the home screen, touch **Settings > Device > Preferences > Date and Time > Configure**.
- 2 Configure the settings.

Configuring daylight saving time

Note: Make sure that fax is configured. For more information, see the [Setting up the printer to fax](#) section.

- 1 From the home screen, touch **Settings > Device > Preferences > Date and Time > Configure**.
- 2 In the Time Zone menu, touch **(UTC+user) Custom**.
- 3 Touch **UTC (GMT) Offset**, and then configure the settings.

Configuring the fax speaker settings

Note: Make sure that fax is configured. For more information, see the [Setting up the printer to fax](#) section.

- 1 From the home screen, touch **Settings > Fax > Fax Setup > Speaker Settings**.
- 2 Do the following:
 - Set Speaker Mode to **Always On**.
 - Set Speaker Volume to **High**.
 - Enable Ringer Volume.

Configuring the e-mail SMTP settings

Configure the Simple Mail Transfer Protocol (SMTP) settings to send a scanned document through e-mail. The settings vary with each e-mail service provider.

Before you begin, make sure that the printer is connected to a network and that the network is connected to the Internet.

Using the Embedded Web Server

- 1 Open a web browser, and then type the printer IP address in the address field.

Notes:

- View the printer IP address on the printer home screen. The IP address appears as four sets of numbers separated by periods, such as 123.123.123.123.
- If you are using a proxy server, then temporarily disable it to load the web page correctly.

- 2 Click **Settings > E-mail**.
- 3 From the E-mail Setup section, configure the settings.

Notes:

- For more information, see the list of [e-mail service providers](#).

- For e-mail service providers that are not on the list, contact your provider and ask for the settings.

4 Click **Save**.

Using the Settings menu in the printer

1 From the home screen, touch **Settings > E-mail > E-mail Setup**.

2 Configure the settings.

Notes:

- For more information, see the list of [e-mail service providers](#).
- For e-mail service providers that are not on the list, contact your provider and ask for the settings.

E-mail service providers

- [AOL Mail](#)
- [Comcast Mail](#)
- [Gmail](#)
- [iCloud Mail](#)
- [Mail.com](#)
- [NetEase Mail \(mail.126.com\)](#)
- [NetEase Mail \(mail.163.com\)](#)
- [NetEase Mail \(mail.yeah.net\)](#)
- [Outlook Live or Microsoft 365](#)
- [QQ Mail](#)
- [Sina Mail](#)
- [Sohu Mail](#)
- [Yahoo! Mail](#)
- [Zoho Mail](#)

Notes:

- If you encounter errors using the settings provided, then contact your e-mail service provider.
- For e-mail service providers that are not on the list, contact your provider.

AOL Mail

| Setting | Value |
|------------------------------------|-----------------------------|
| Primary SMTP Gateway | smtp.aol.com |
| Primary SMTP Gateway Port | 587 |
| Use SSL/TLS | Required |
| Require Trusted Certificate | Disabled |
| Reply Address | Your e-mail address |
| SMTP Server Authentication | Login / Plain |
| Device-Initiated E-mail | Use Device SMTP Credentials |

| Setting | Value |
|------------------------|--|
| Device UserID | Your e-mail address |
| Device Password | App password Note: To create an app password, go to the AOL Account Security page, log in to your account, and then click Generate app password . |

Comcast Mail

| Setting | Value |
|------------------------------------|-----------------------------|
| Primary SMTP Gateway | smtp.comcast.net |
| Primary SMTP Gateway Port | 587 |
| Use SSL/TLS | Required |
| Require Trusted Certificate | Disabled |
| Reply Address | Your e-mail address |
| SMTP Server Authentication | Login / Plain |
| Device-Initiated E-mail | Use Device SMTP Credentials |
| Device UserID | Your e-mail address |
| Device Password | Account password |

Note: Make sure that the Third Party Access Security setting is enabled on your account. For more information, go to the [Comcast Xfinity Connect help page](#).

Gmail™

Note: Make sure that two-step verification is enabled on your Google account. To enable two-step verification, go to the [Google Account Security](#) page, log in to your account, and then from the “Signing in to Google” section, click **2-Step Verification**.

| Setting | Value |
|------------------------------------|-----------------------------|
| Primary SMTP Gateway | smtp.gmail.com |
| Primary SMTP Gateway Port | 587 |
| Use SSL/TLS | Required |
| Require Trusted Certificate | Disabled |
| Reply Address | Your e-mail address |
| SMTP Server Authentication | Login / Plain |
| Device-Initiated E-mail | Use Device SMTP Credentials |
| Device UserID | Your e-mail address |

| Setting | Value |
|------------------------|---|
| Device Password | App password Notes: <ul style="list-style-type: none"> To create an app password, go to the Google Account Security page, log in to your account, and then from the “Signing in to Google” section, click App passwords. “App passwords” shows only if two-step verification is enabled. |

iCloud Mail

Note: Make sure that two-step verification is enabled on your account.

| Setting | Value |
|------------------------------------|--|
| Primary SMTP Gateway | smtp.mail.me.com |
| Primary SMTP Gateway Port | 587 |
| Use SSL/TLS | Required |
| Require Trusted Certificate | Disabled |
| Reply Address | Your e-mail address |
| SMTP Server Authentication | Login / Plain |
| Device-Initiated E-mail | Use Device SMTP Credentials |
| Device UserID | Your e-mail address |
| Device Password | App password Note: To create an app password, go to the iCloud Account Management page, log in to your account, and then from the Security section, click Generate Password . |

Mail.com

| Setting | Value |
|------------------------------------|-----------------------------|
| Primary SMTP Gateway | smtp.mail.com |
| Primary SMTP Gateway Port | 587 |
| Use SSL/TLS | Required |
| Require Trusted Certificate | Disabled |
| Reply Address | Your e-mail address |
| SMTP Server Authentication | Login / Plain |
| Device-Initiated E-mail | Use Device SMTP Credentials |
| Device UserID | Your e-mail address |
| Device Password | Account password |

NetEase Mail (mail.126.com)

Note: Make sure that the SMTP service is enabled on your account. To enable the service, from the NetEase Mail home page, click **Settings > POP3/SMTP/IMAP**, and then enable either **IMAP/SMTP service** or **POP3/SMTP service**.

| Setting | Value |
|------------------------------------|---|
| Primary SMTP Gateway | smtp.126.com |
| Primary SMTP Gateway Port | 465 |
| Use SSL/TLS | Required |
| Require Trusted Certificate | Disabled |
| Reply Address | Your e-mail address |
| SMTP Server Authentication | Login / Plain |
| Device-Initiated E-mail | Use Device SMTP Credentials |
| Device UserID | Your e-mail address |
| Device Password | Authorization password Note: The authorization password is provided when IMAP/SMTP service or POP3/SMTP service is enabled. |

NetEase Mail (mail.163.com)

Note: Make sure that the SMTP service is enabled on your account. To enable the service, from the NetEase Mail home page, click **Settings > POP3/SMTP/IMAP**, and then enable either **IMAP/SMTP service** or **POP3/SMTP service**.

| Setting | Value |
|------------------------------------|---|
| Primary SMTP Gateway | smtp.163.com |
| Primary SMTP Gateway Port | 465 |
| Use SSL/TLS | Required |
| Require Trusted Certificate | Disabled |
| Reply Address | Your e-mail address |
| SMTP Server Authentication | Login / Plain |
| Device-Initiated E-mail | Use Device SMTP Credentials |
| Device UserID | Your e-mail address |
| Device Password | Authorization password Note: The authorization password is provided when IMAP/SMTP service or POP3/SMTP service is enabled. |

NetEase Mail (mail.yeah.net)

Note: Make sure that the SMTP service is enabled on your account. To enable the service, from the NetEase Mail home page, click **Settings > POP3/SMTP/IMAP**, and then enable either **IMAP/SMTP service** or **POP3/SMTP service**.

| Setting | Value |
|------------------------------------|---|
| Primary SMTP Gateway | smtp.yeah.net |
| Primary SMTP Gateway Port | 465 |
| Use SSL/TLS | Required |
| Require Trusted Certificate | Disabled |
| Reply Address | Your e-mail address |
| SMTP Server Authentication | Login / Plain |
| Device-Initiated E-mail | Use Device SMTP Credentials |
| Device UserID | Your e-mail address |
| Device Password | Authorization password Note: The authorization password is provided when IMAP/SMTP service or POP3/SMTP service is enabled. |

Outlook Live or Microsoft 365

These settings apply to outlook.com and hotmail.com e-mail domains, and Microsoft 365 accounts.

| Setting | Value |
|------------------------------------|--|
| Primary SMTP Gateway | smtp.office365.com |
| Primary SMTP Gateway Port | 587 |
| Use SSL/TLS | Required |
| Require Trusted Certificate | Disabled |
| Reply Address | Your e-mail address |
| SMTP Server Authentication | Login / Plain |
| Device-Initiated E-mail | Use Device SMTP Credentials |
| Device UserID | Your e-mail address |
| Device Password | Account password or app password Notes: <ul style="list-style-type: none"> • For accounts with two-step verification disabled, use your account password. • For outlook.com or hotmail.com accounts with two-step verification enabled, use an app password. To create an app password, go to the Outlook Live Account Management page, and then log in to your account. |

Note: For additional setup options for business using Microsoft 365, go to the [Microsoft 365 help page](#).

QQ Mail

Note: Make sure that the SMTP service is enabled on your account. To enable the service, from the QQ Mail home page, click **Settings > Account**. From the POP3/IMAP/SMTP/Exchange/CardDAV/CalDAV Service section, enable either **POP3/SMTP service** or **IMAP/SMTP service**.

| Setting | Value |
|------------------------------------|---|
| Primary SMTP Gateway | smtp.qq.com |
| Primary SMTP Gateway Port | 587 |
| Use SSL/TLS | Required |
| Require Trusted Certificate | Disabled |
| Reply Address | Your e-mail address |
| SMTP Server Authentication | Login / Plain |
| Device-Initiated E-mail | Use Device SMTP Credentials |
| Device UserID | Your e-mail address |
| Device Password | Authorization code Note: To generate an authorization code, from the QQ Mail home page, click Settings > Account , and then from the POP3/IMAP/SMTP/Exchange/CardDAV/CalDAV Service section, click Generate authorization code . |

Sina Mail

Note: Make sure that the POP3/SMTP service is enabled on your account. To enable the service, from the Sina Mail home page, click **Settings > More settings > User-end POP/IMAP/SMTP**, and then enable **POP3/SMTP service**.

| Setting | Value |
|------------------------------------|--|
| Primary SMTP Gateway | smtp.sina.com |
| Primary SMTP Gateway Port | 587 |
| Use SSL/TLS | Required |
| Require Trusted Certificate | Disabled |
| Reply Address | Your e-mail address |
| SMTP Server Authentication | Login / Plain |
| Device-Initiated E-mail | Use Device SMTP Credentials |
| Device UserID | Your e-mail address |
| Device Password | Authorization code Note: To create an authorization code, from the e-mail home page, click Settings > More settings > User-end POP/IMAP/SMTP , and then enable Authorization code status . |

Sohu Mail

Note: Make sure that the SMTP service is enabled on your account. To enable the service, from the Sohu Mail home page, click **Options > Settings > POP3/SMTP/IMAP**, and then enable either **IMAP/SMTP service** or **POP3/SMTP service**.

| Setting | Value |
|------------------------------------|---|
| Primary SMTP Gateway | smtp.sohu.com |
| Primary SMTP Gateway Port | 465 |
| Use SSL/TLS | Required |
| Require Trusted Certificate | Disabled |
| Reply Address | Your e-mail address |
| SMTP Server Authentication | Login / Plain |
| Device-Initiated E-mail | Use Device SMTP Credentials |
| Device UserID | Your e-mail address |
| Device Password | Independent password Note: The independent password is provided when IMAP/SMTP service or POP3/SMTP service is enabled. |

Yahoo! Mail

| Setting | Value |
|------------------------------------|--|
| Primary SMTP Gateway | smtp.mail.yahoo.com |
| Primary SMTP Gateway Port | 587 |
| Use SSL/TLS | Required |
| Require Trusted Certificate | Disabled |
| Reply Address | Your e-mail address |
| SMTP Server Authentication | Login / Plain |
| Device-Initiated E-mail | Use Device SMTP Credentials |
| Device UserID | Your e-mail address |
| Device Password | App password Note: To create an app password, go to the Yahoo Account Security page, log in to your account, and then click Generate app password . |

Zoho Mail

| Setting | Value |
|------------------------------------|---------------|
| Primary SMTP Gateway | smtp.zoho.com |
| Primary SMTP Gateway Port | 587 |
| Use SSL/TLS | Required |
| Require Trusted Certificate | Disabled |

| Setting | Value |
|-----------------------------------|---|
| Reply Address | Your e-mail address |
| SMTP Server Authentication | Login / Plain |
| Device-Initiated E-mail | Use Device SMTP Credentials |
| Device UserID | Your e-mail address |
| Device Password | Account password or app password Notes: <ul style="list-style-type: none"> • For accounts with two-step verification disabled, use your account password. • For accounts with two-step verification enabled, use an app password. To create an app password, go to the Zoho Mail Account Security page, log in to your account, and then from the Application-Specific Passwords section, click Generate New Password. |

Loading paper and specialty media

Setting the paper size and type

- 1 From the home screen, touch **Settings** > **Paper** > **Tray Configuration** > **Paper Size/Type** > select a paper source.
- 2 Set the paper size and type.

Configuring Universal paper settings

- 1 From the home screen, touch **Settings** > **Paper** > **Media Configuration** > **Universal Setup**.
- 2 Configure the settings.

Loading trays

 **CAUTION—TIPPING HAZARD:** To reduce the risk of equipment instability, load each tray separately. Keep all other trays closed until needed.

- 1 Remove the tray.

Note: To avoid paper jams, do not remove the tray while the printer is busy.



2 Adjust the guides to match the size of the paper that you are loading.

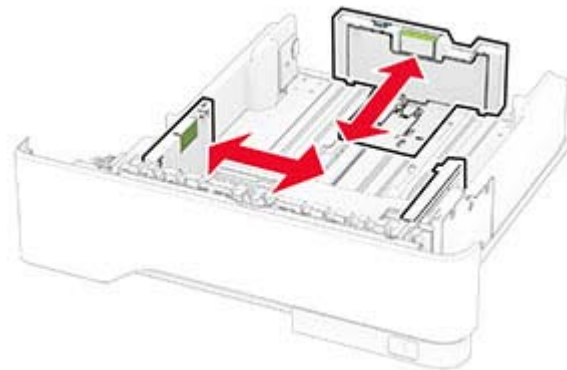

3 Flex, fan, and align the paper edges before loading.



4 Load the paper stack with the printable side facedown, and then make sure that the guides fit snugly against the paper.

Notes:

- Load letterhead facedown with the header toward the front of the tray for one-sided printing.
- Load letterhead faceup with the header toward the back of the tray for two-sided printing.
- Do not slide paper into the tray.
- To avoid paper jams, make sure that the stack height is below the maximum paper fill indicator.

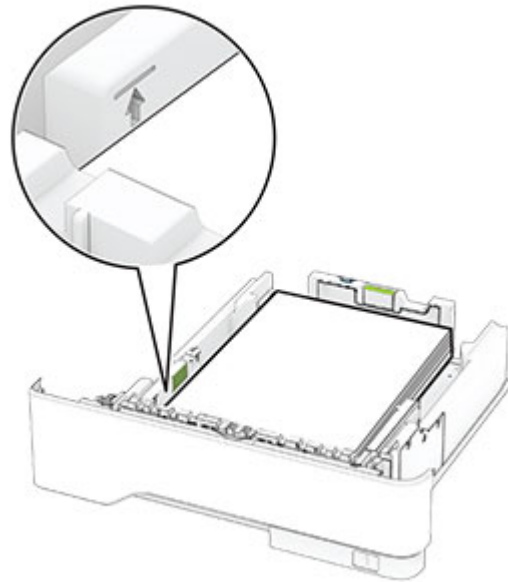

5 Insert the tray.

If necessary, set the paper size and paper type from the control panel to match the paper loaded.

Loading the multipurpose feeder

1 Open the multipurpose feeder.

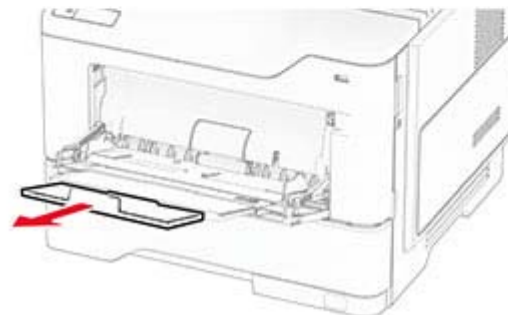
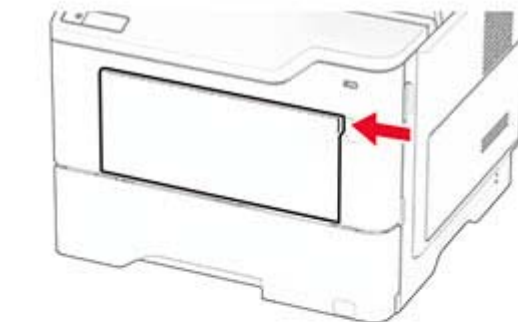

- 2 Flex, fan, and align the paper edges before loading.



- 3 Load paper with the printable side faceup.

Notes:

- Load letterhead faceup with the header toward the rear of the printer for one-sided printing.
- Load letterhead facedown with the header toward the front of the printer for two-sided printing.
- Load envelopes with the flap facedown on the left side.

Warning—Potential Damage: Do not use envelopes with stamps, clasps, snaps, windows, coated linings, or self-stick adhesives.

- 4 Adjust the guide to match the size of the paper that you are loading.

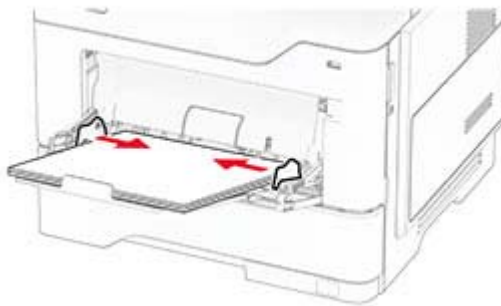

- 5 From the control panel, set the paper size and paper type to match the paper loaded.

Linking trays

- 1 From the home screen, touch **Settings** > **Paper** > **Tray Configuration** > select a paper source.
- 2 Set the same paper size and paper type for the trays that you are linking.
- 3 From the home screen, touch **Settings** > **Device** > **Maintenance** > **Configuration Menu** > **Tray Configuration** > **Tray Linking**.
- 4 Touch **Automatic**.

To unlink trays, make sure that no trays have the same paper size and paper type settings.

Warning—Potential Damage: The temperature of the fuser varies according to the specified paper type. To avoid printing issues, match the paper type setting in the printer with the paper loaded in the tray.

Installing and updating software, drivers, and firmware

Installing the printer software

Notes:

- The print driver is included in the software installer package.
- For Macintosh computers with macOS version 10.7 or later, you do not need to install the driver to print on an AirPrint-certified printer. If you want custom printing features, then download the print driver.

1 Obtain a copy of the software installer package.

- From the software CD that came with your printer.
- From our website or the place where you purchased the printer.

2 Run the installer, and then follow the instructions on the computer screen.

Installing the fax driver

1 Go to our website or the place where you purchased the printer, and then obtain the installer package.

2 Run the installer, and then follow the instructions on the computer screen.

Adding printers to a computer

Before you begin, do one of the following:

- Connect the printer and the computer to the same network. For more information on connecting the printer to a network, see [“Connecting the printer to a Wi-Fi network” on page 71](#).
- Connect the computer to the printer. For more information, see [“Connecting a computer to the printer” on page 73](#).
- Connect the printer to the computer using a USB cable. For more information, see [“Attaching cables” on page 18](#).

Note: The USB cable is sold separately.

For Windows users

1 From a computer, install the print driver.

Note: For more information, see [“Installing the printer software” on page 45](#).

2 Open the printers folder, and then click **Add a printer or scanner**.

3 Depending on your printer connection, do one of the following:

- Select a printer from the list, and then click **Add device**.
- Click **Show Wi-Fi Direct printers**, select a printer, and then click **Add device**.
- Click **The printer that I want isn't listed**, and then from the Add Printer window, do the following:
 - a Select **Add a printer using a TCP/IP address or hostname**, and then click **Next**.
 - b In the “Hostname or IP address” field, type the printer IP address, and then click **Next**.

Notes:

- View the printer IP address on the printer home screen. The IP address appears as four sets of numbers separated by periods, such as 123.123.123.123.
 - If you are using a proxy server, then temporarily disable it to load the web page correctly.
- c** Select a print driver, and then click **Next**.
 - d** Select **Use the print driver that is currently installed (recommended)**, and then click **Next**.
 - e** Type a printer name, and then click **Next**.
 - f** Select a printer sharing option, and then click **Next**.
 - g** Click **Finish**.

For Macintosh users

- 1** From a computer, open **Printers & Scanners**.
- 2** Click **+**, and then select a printer.
- 3** From the Use menu, select a print driver.

Notes:

- To use the Macintosh print driver, select either **AirPrint** or **Secure AirPrint**.
- If you want custom printing features, then select the manufacturer print driver. To install the driver, see [“Installing the printer software” on page 45](#).

- 4** Add the printer.

Updating firmware

To enhance printer performance and fix issues, update the printer firmware regularly.

For more information on updating the firmware, contact your sales representative.

- 1** Open a web browser, and then type the printer IP address in the address field.

Notes:

- View the printer IP address on the printer home screen. The IP address appears as four sets of numbers separated by periods, such as 123.123.123.123.
- If you are using a proxy server, then temporarily disable it to load the web page correctly.

- 2** Click **Settings > Device > Update Firmware**.
- 3** Do either of the following:
 - Click **Check for updates now > I agree, start update**.
 - Upload the flash file.
 - a** Browse to the flash file.
 - b** Click **Upload > Start**.

Exporting or importing a configuration file

You can export the configuration settings of your printer into a text file, and then import the file to apply the settings to other printers.

- 1 Open a web browser, and then type the printer IP address in the address field.

Notes:

- View the printer IP address on the printer home screen. The IP address appears as four sets of numbers separated by periods, such as 123.123.123.123.
- If you are using a proxy server, then temporarily disable it to load the web page correctly.

- 2 From the Embedded Web Server, click **Export Configuration** or **Import Configuration**.

- 3 Follow the instructions on the screen.

- 4 If the printer supports applications, then do the following:

- a Click **Apps** > select the application > **Configure**.
- b Click **Export** or **Import**.

Adding available options in the print driver

For Windows users

- 1 Open the printers folder.
- 2 Select the printer you want to update, and then do either of the following:
 - For Windows 7 or later, select **Printer properties**.
 - For earlier versions, select **Properties**.
- 3 Navigate to the Configuration tab, and then select **Update Now - Ask Printer**.
- 4 Apply the changes.

For Macintosh users

- 1 From System Preferences in the Apple menu, navigate to your printer, and then select **Options & Supplies**.
- 2 Navigate to the list of hardware options, and then add any installed options.
- 3 Apply the changes.

Installing hardware options

Available internal options

- Intelligent storage drive
 - Fonts
 - Simplified Chinese
 - Traditional Chinese
 - Japanese

- Korean
- Arabic
- Mass storage
- Hard disk
- Licensed features
 - IPDS
 - Bar Code
- Internal solutions port
 - RS-232C Serial Interface Card
 - Parallel 1284-B Interface Card
 - MarkNet™ N8230 Fiber Ethernet
- MarkNet N8450 Wireless Print Server
- Trusted Platform Module

Notes:

- An intelligent storage drive or a hard disk is required to activate Forms Merge and some IPDS features.
- Some options are available only in some printer models. For more information, contact your dealer.

Installing optional trays

 **CAUTION—SHOCK HAZARD:** To avoid the risk of electrical shock, if you are accessing the controller board or installing optional hardware or memory devices sometime after setting up the printer, then turn the printer off, and unplug the power cord from the electrical outlet before continuing. If you have any other devices attached to the printer, then turn them off as well, and unplug any cables going into the printer.

- 1 Turn off the printer.
- 2 Unplug the power cord from the electrical outlet, and then from the printer.
- 3 Unpack the optional tray, and then remove all packing material.
- 4 Align the printer with the optional tray, and then lower the printer into place.

 **CAUTION—POTENTIAL INJURY:** If the printer weight is greater than 20 kg (44 lb), then it may require two or more people to lift it safely.

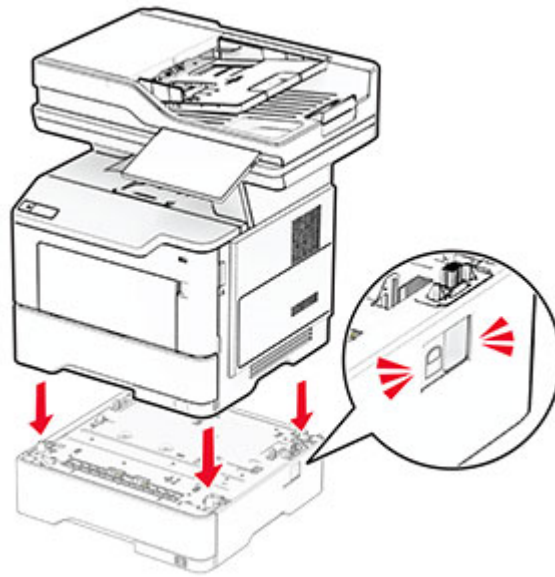

- 5 Connect the power cord to the printer, and then to the electrical outlet.

CAUTION—POTENTIAL INJURY: To avoid the risk of fire or electrical shock, connect the power cord to an appropriately rated and properly grounded electrical outlet that is near the product and easily accessible.

- 6 Turn on the printer.

Add the tray in the print driver to make it available for print jobs. For more information, see [“Adding available options in the print driver” on page 47](#).

Installing the intelligent storage drive

CAUTION—SHOCK HAZARD: To avoid the risk of electrical shock, if you are accessing the controller board or installing optional hardware or memory devices sometime after setting up the printer, then turn the printer off, and unplug the power cord from the electrical outlet before continuing. If you have any other devices attached to the printer, then turn them off as well, and unplug any cables going into the printer.

- 1 Turn off the printer.
- 2 Unplug the power cord from the electrical outlet, and then from the printer.
- 3 Using a flat-head screwdriver, open the controller board access cover.

Warning—Potential Damage: Controller board electronic components are easily damaged by static electricity. Touch a metal surface on the printer before touching any controller board components or connectors.

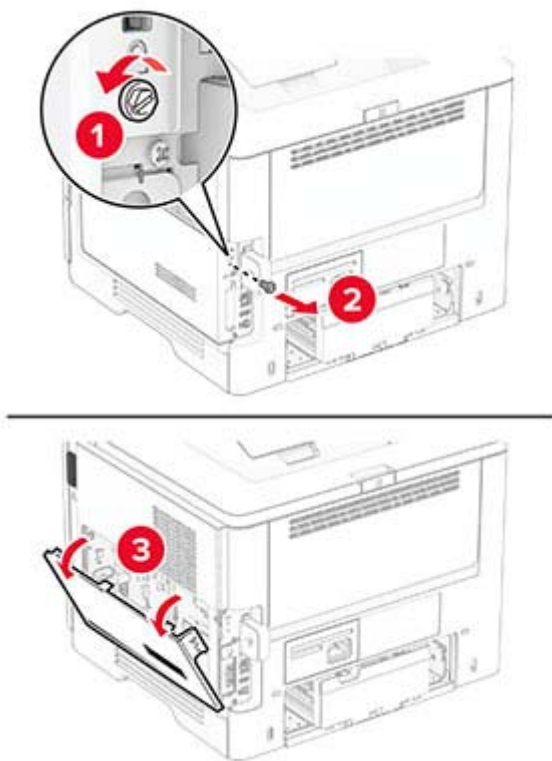

4 Remove the fax card.

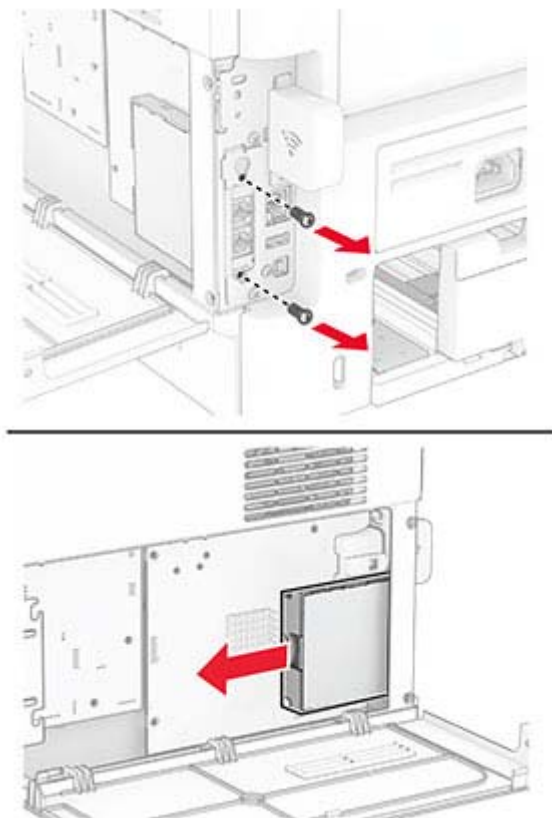

5 Unpack the intelligent storage drive.

Warning—Potential Damage: Avoid touching the connection points along the edge of the storage drive.

6 Locate the ISD connector.

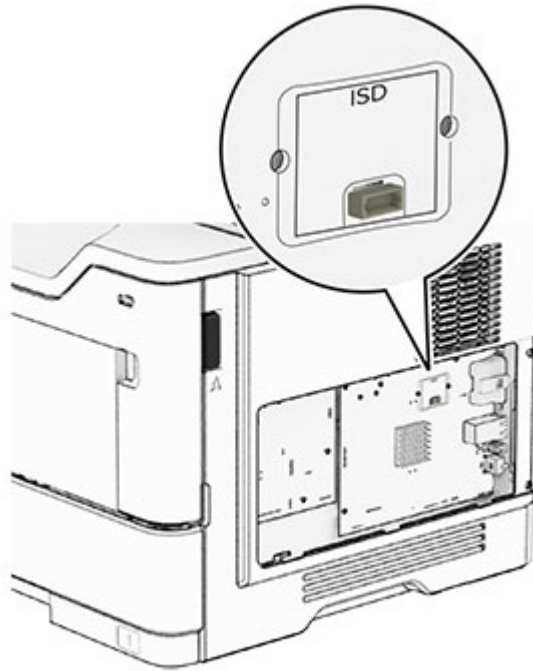

7 Insert the ISD to its connector.

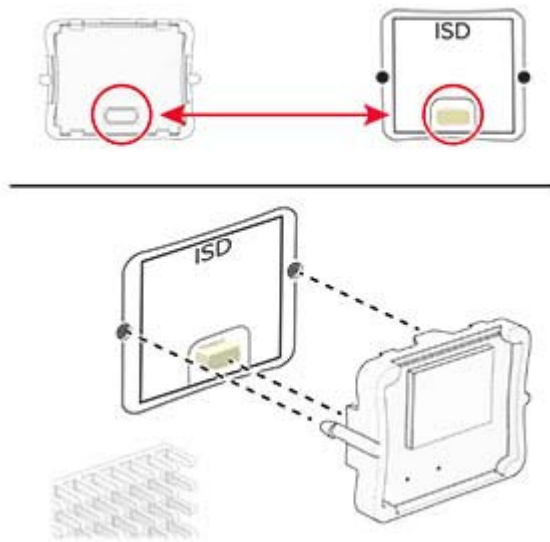

8 Install the fax card, and then install the screws.

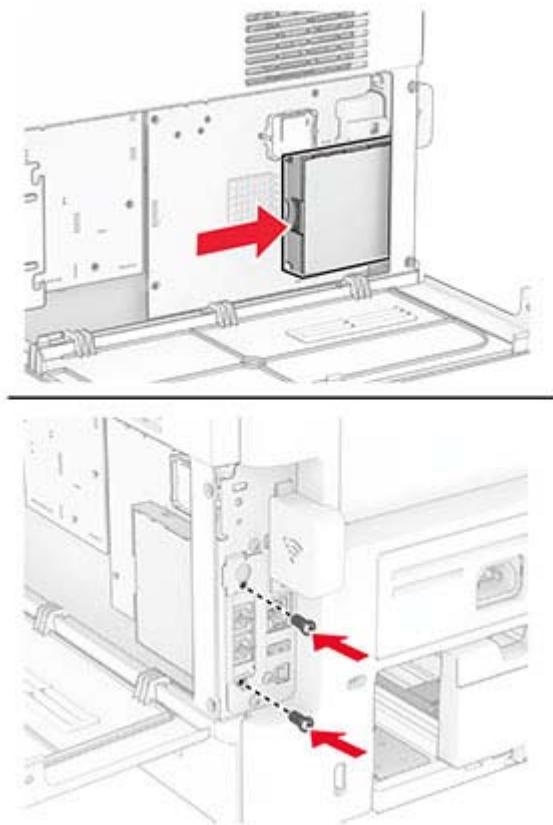

- 9 Close the controller board access cover, and then install the screw.

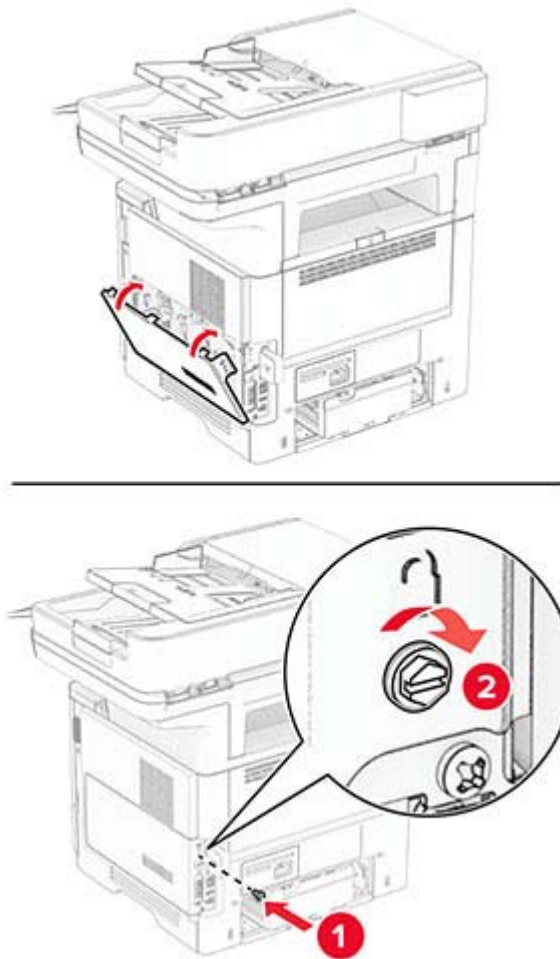

- 10 Connect the power cord to the printer, and then to the electrical outlet.

⚠ CAUTION—POTENTIAL INJURY: To avoid the risk of fire or electrical shock, connect the power cord to an appropriately rated and properly grounded electrical outlet that is near the product and easily accessible.

- 11 Turn on the printer.

Installing a printer hard disk

Note: These instructions apply only to printers that support printer hard disk.

⚠ CAUTION—SHOCK HAZARD: To avoid the risk of electrical shock, if you are accessing the controller board or installing optional hardware or memory devices sometime after setting up the printer, then turn the printer off, and unplug the power cord from the electrical outlet before continuing. If you have any other devices attached to the printer, then turn them off as well, and unplug any cables going into the printer.

- 1 Turn off the printer.
- 2 Unplug the power cord from the electrical outlet, and then from the printer.

- 3** Using a flat-head screwdriver, open the controller board access cover.

Warning—Potential Damage: Controller board electronic components are easily damaged by static electricity. Touch a metal surface on the printer before touching any controller board components or connectors.

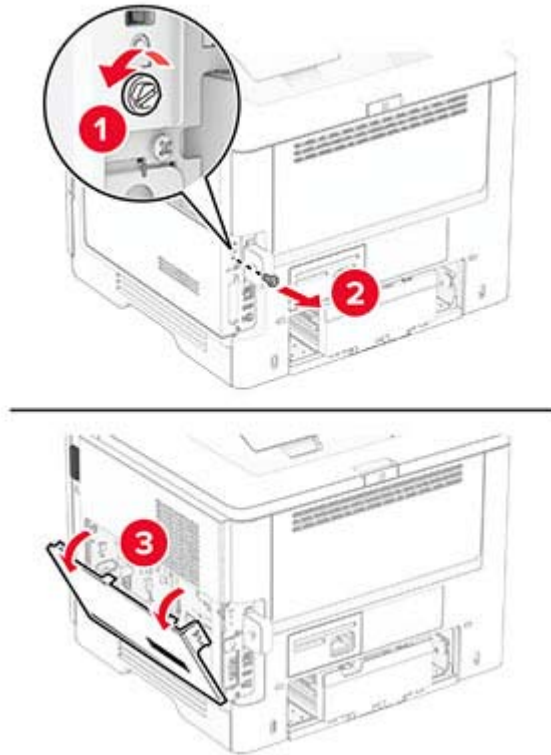

- 4** Unpack the hard disk.
- 5** Attach the hard disk to the controller board, and then install the screws.

Warning—Potential Damage: Do not touch or press the center of the hard disk.

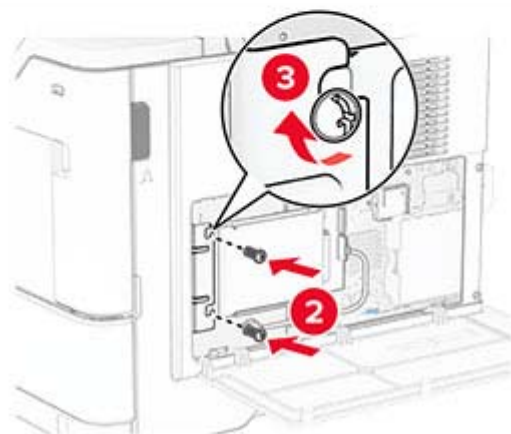
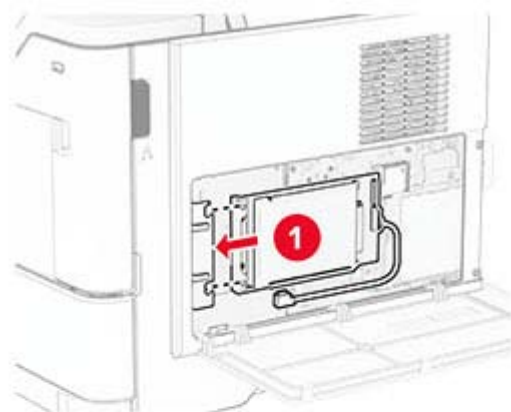

6 Attach the hard disk interface cable to the controller board.

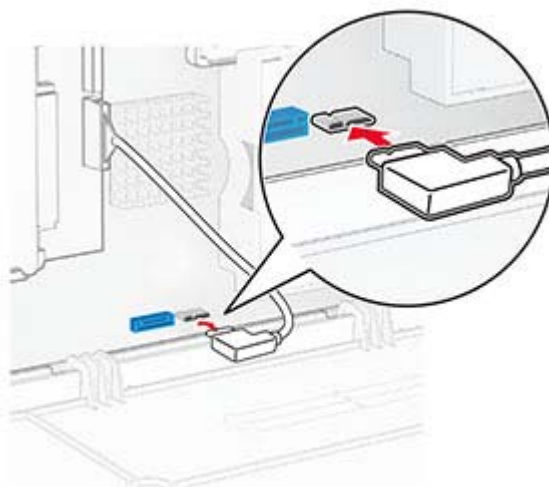

- 7 Close the controller board access cover, and then install the screw.

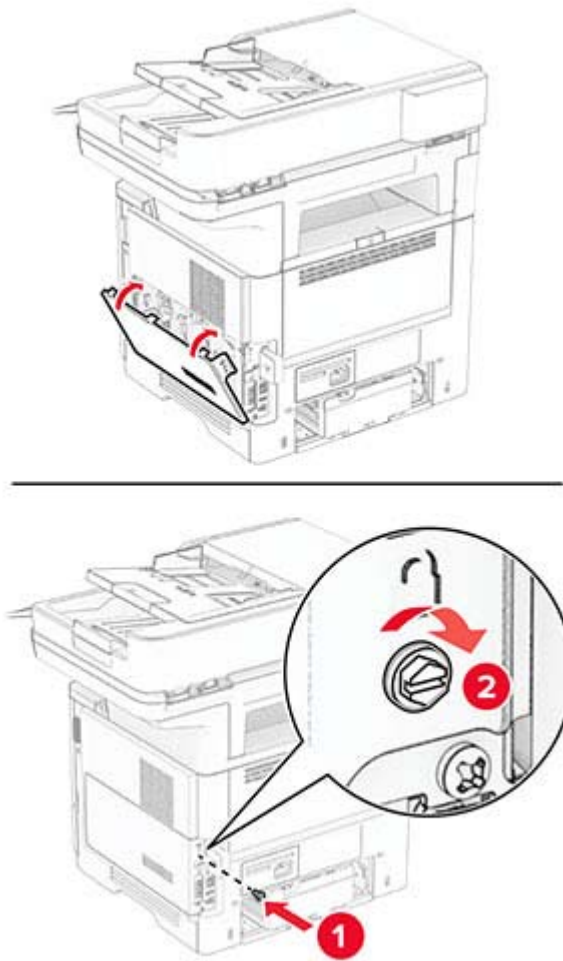

- 8 Connect the power cord to the printer, and then to the electrical outlet.

⚠ CAUTION—POTENTIAL INJURY: To avoid the risk of fire or electrical shock, connect the power cord to an appropriately rated and properly grounded electrical outlet that is near the product and easily accessible.

- 9 Turn on the printer.

Installing an internal solutions port

⚠ CAUTION—SHOCK HAZARD: To avoid the risk of electrical shock, if you are accessing the controller board or installing optional hardware or memory devices sometime after setting up the printer, then turn the printer off, and unplug the power cord from the electrical outlet before continuing. If you have any other devices attached to the printer, then turn them off as well, and unplug any cables going into the printer.

- 1 Turn off the printer.
- 2 Unplug the power cord from the electrical outlet, and then from the printer.

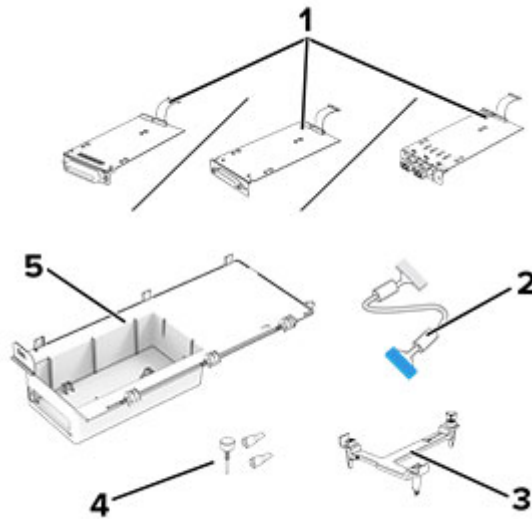
3 Unpack the internal solutions port (ISP) kit.

| | |
|----------|---|
| 1 | ISP <ul style="list-style-type: none">• RS-232C Serial Interface Card• Parallel 1284-B Interface Card• MarkNet N8230 Fiber Ethernet |
| 2 | ISP extended cable |
| 3 | Mounting bracket |
| 4 | Thumbscrews |
| 5 | Housing |

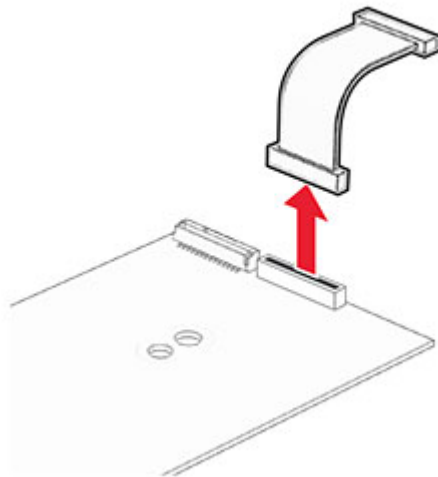
4 Remove the preinstalled interface cable from the ISP.

5 Install the ISP into its housing.

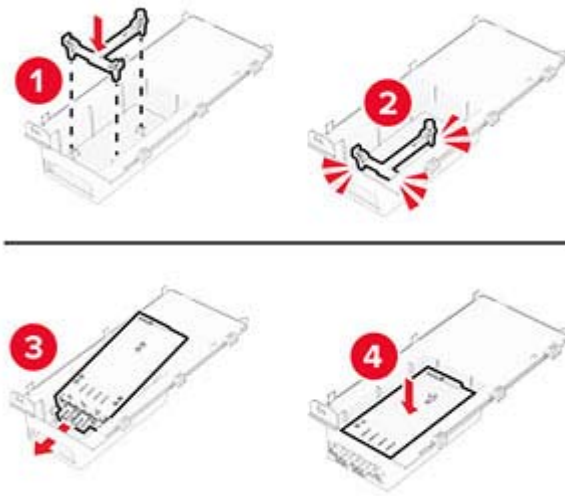

6 Secure the ISP in place, and then attach the ISP extended cable.

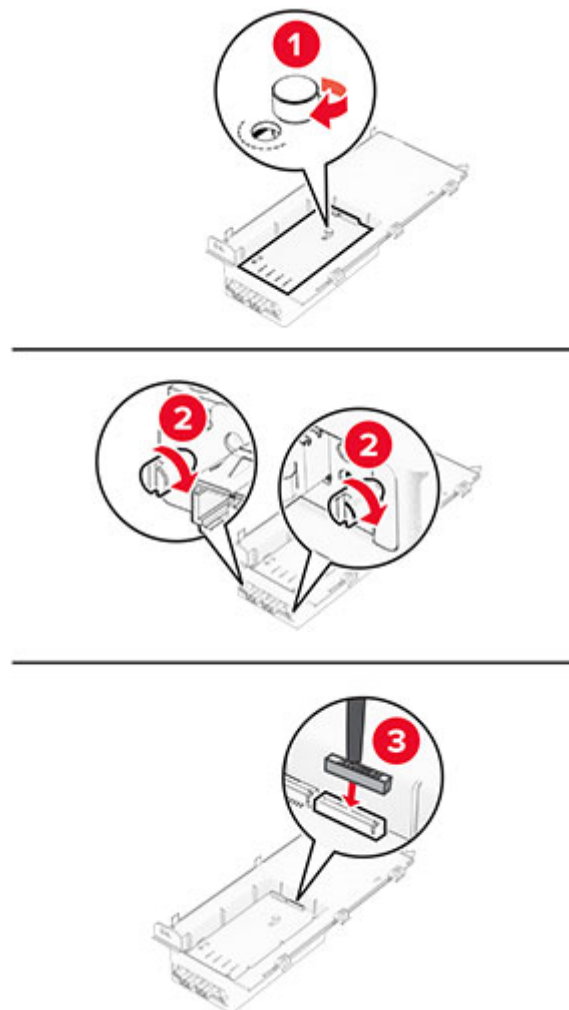

7 Using a flat-head screwdriver, remove the controller board access cover.

Warning—Potential Damage: Controller board electronic components are easily damaged by static electricity. Touch a metal surface on the printer before touching any controller board electronic components or connectors.

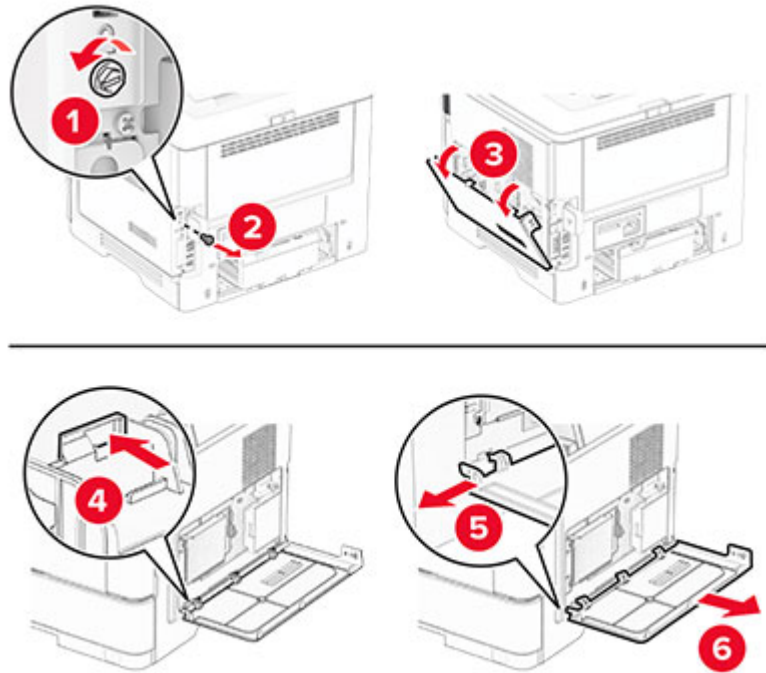

8 Attach the ISP kit to the printer.

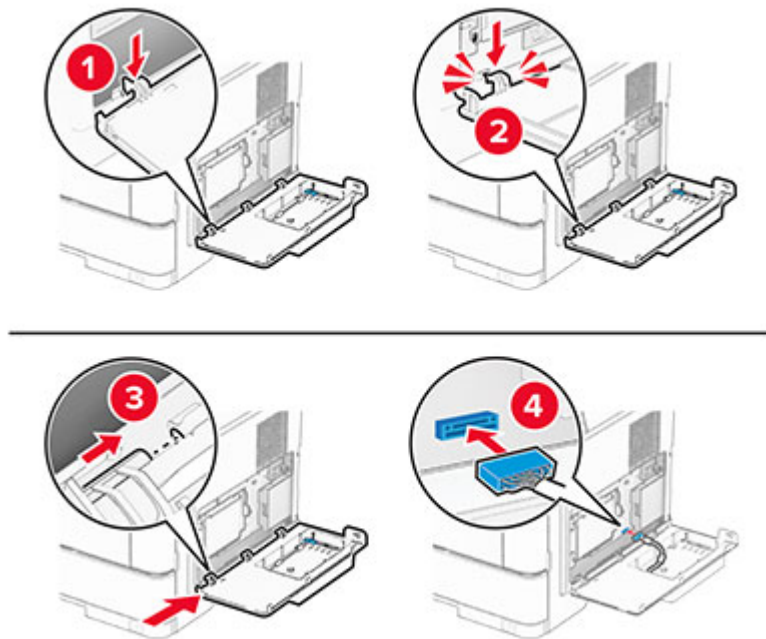

- 9 Close the ISP kit, and then install the screw.

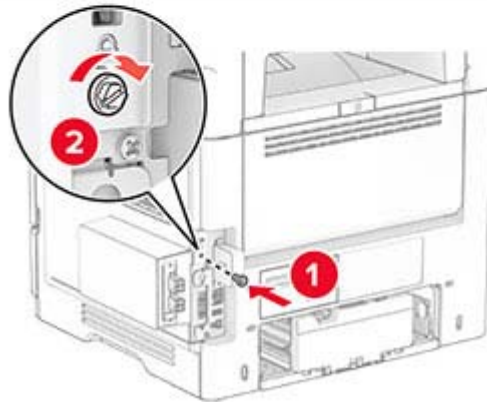

- 10 Connect the power cord to the printer, and then to the electrical outlet.

CAUTION—POTENTIAL INJURY: To avoid the risk of fire or electrical shock, connect the power cord to an appropriately rated and properly grounded electrical outlet that is near the product and easily accessible.

- 11 Turn on the printer.

Installing the Trusted Platform Module

CAUTION—SHOCK HAZARD: To avoid the risk of electrical shock, if you are accessing the controller board or installing optional hardware or memory devices sometime after setting up the printer, then turn the printer off, and unplug the power cord from the electrical outlet before continuing. If you have any other devices attached to the printer, then turn them off as well, and unplug any cables going into the printer.

- 1 Turn off the printer.
- 2 Unplug the power cord from the electrical outlet, and then from the printer.
- 3 Using a flat-head screwdriver, open the controller board access cover.

Warning—Potential Damage: Controller board electronic components are easily damaged by static electricity. Touch a metal surface on the printer before touching any controller board components or connectors.

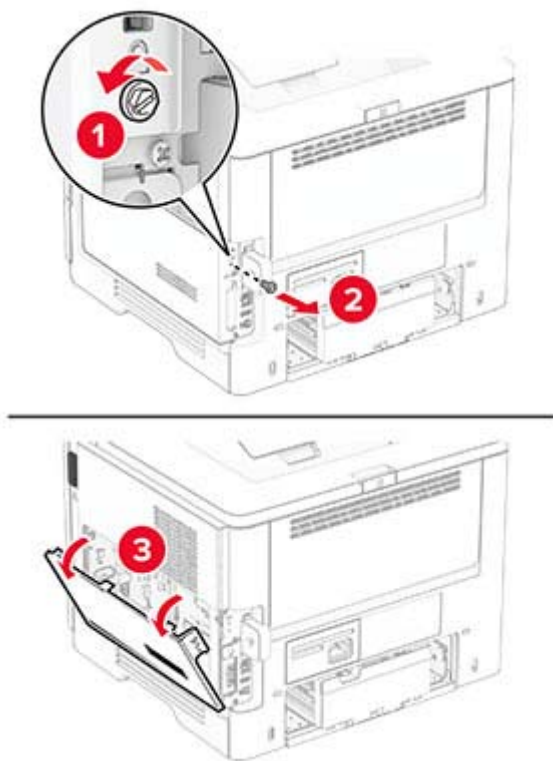

4 Unpack the Trusted Platform Module.

5 Locate the TPM connector.

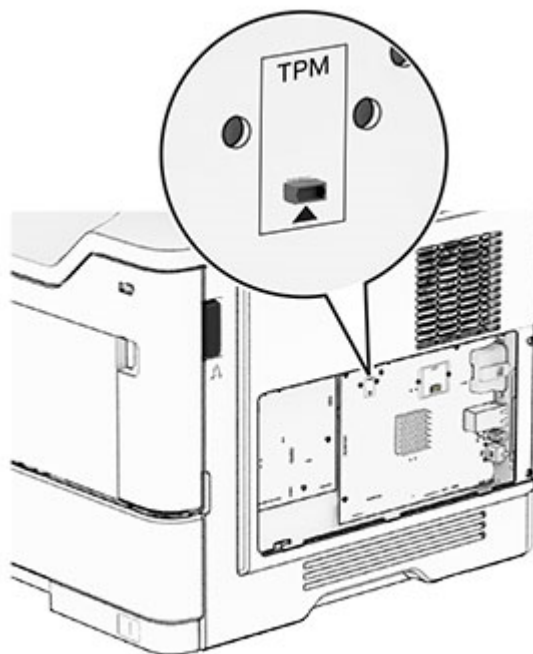

6 Attach the module to the TPM connector.

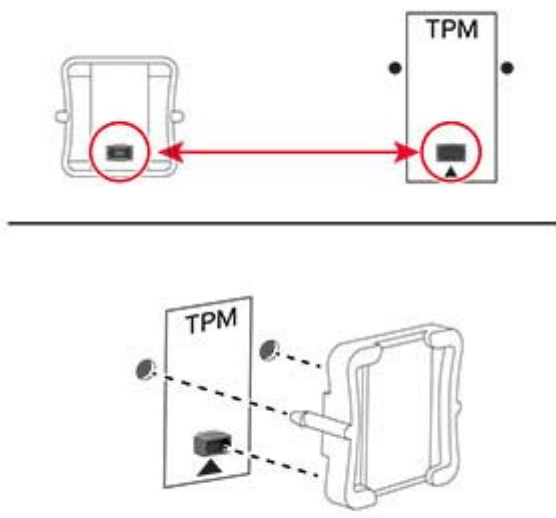

- 7 Close the controller board access cover, and then install the screw.

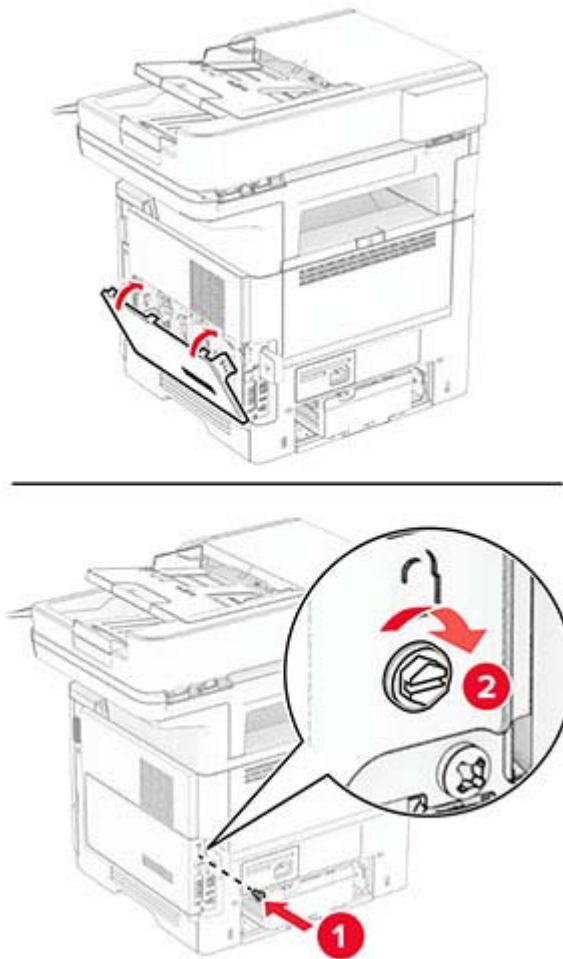

- 8 Connect the power cord to the printer, and then to the electrical outlet.

⚠ CAUTION—POTENTIAL INJURY: To avoid the risk of fire or electrical shock, connect the power cord to an appropriately rated and properly grounded electrical outlet that is near the product and easily accessible.

- 9 Turn on the printer.

Installing MarkNet N8450 Wireless Print Server

⚠ CAUTION—SHOCK HAZARD: To avoid the risk of electrical shock, if you are accessing the controller board or installing optional hardware or memory devices sometime after setting up the printer, then turn the printer off, and unplug the power cord from the electrical outlet before continuing. If you have any other devices attached to the printer, then turn them off as well, and unplug any cables going into the printer.

- 1 Turn off the printer.
- 2 Unplug the power cord from the electrical outlet, and then from the printer.
- 3 Using a flat-head screwdriver, remove the cover for the wireless print server port.

Warning—Potential Damage: Controller board electronic components are easily damaged by static electricity. Touch a metal surface on the printer before touching any controller board components or connectors.

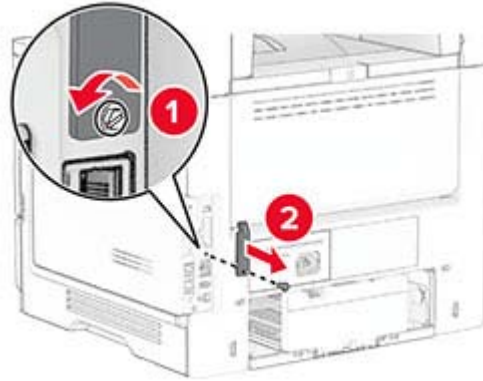

4 Unpack the wireless print server.

5 Insert the wireless print server until it *clicks* into place.

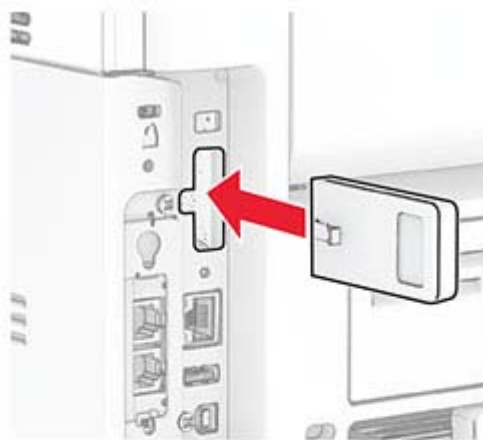

- 6 Attach the cover for the wireless print server.

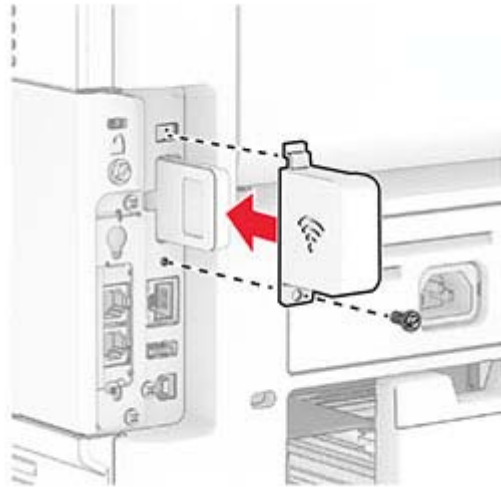

- 7 Connect the power cord to the printer, and then to the electrical outlet.

⚠ CAUTION—POTENTIAL INJURY: To avoid the risk of fire or electrical shock, connect the power cord to an appropriately rated and properly grounded electrical outlet that is near the product and easily accessible.

- 8 Turn on the printer.

Installing the convenience stapler

- 1 Turn off the printer.
- 2 Unplug the power cord from the electrical outlet, and then from the printer.
- 3 Unpack the convenience stapler.
- 4 Remove the column covers.

Note: Do not throw away the column covers.

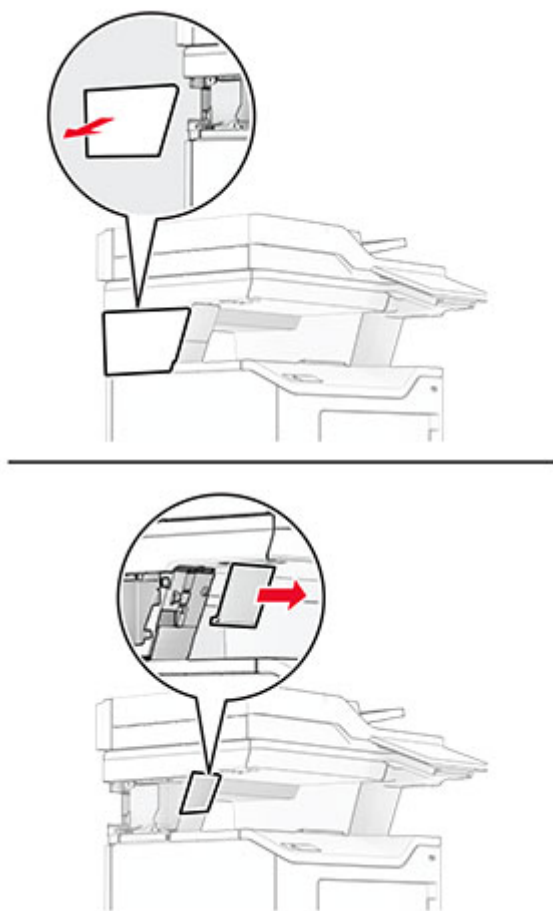

5 Insert the power supply through the printer, and then connect it to the convenience stapler.

Note: To avoid damaging the convenience stapler, use only the power supply that came with it.

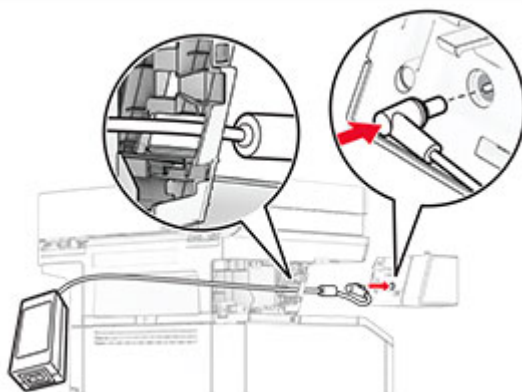
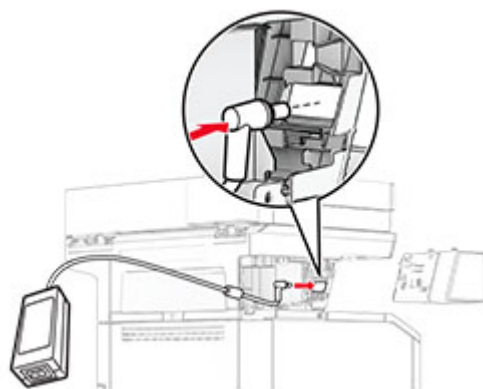

6 Install the convenience stapler.

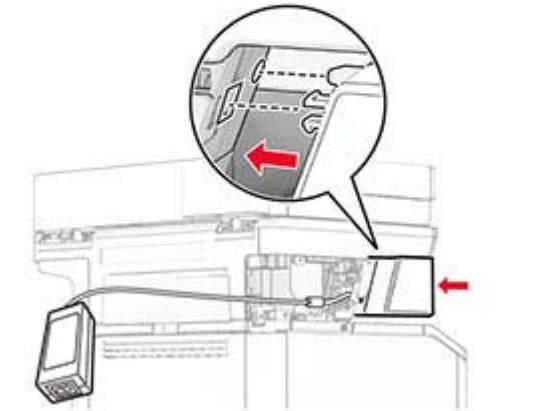
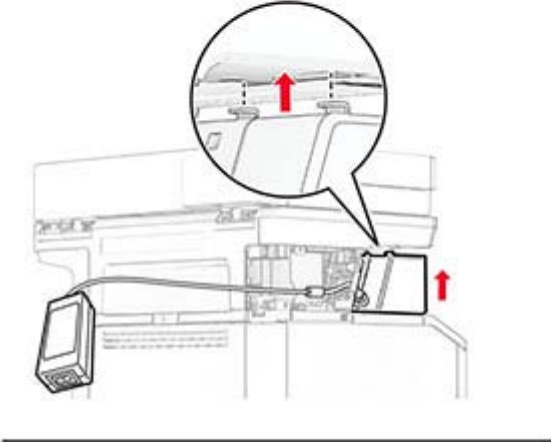
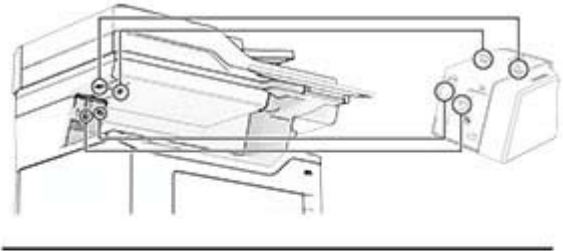

7 Position the power supply properly.

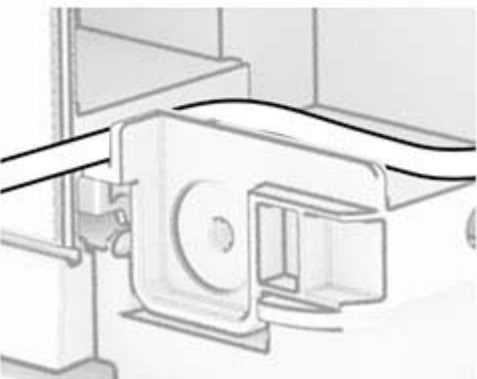
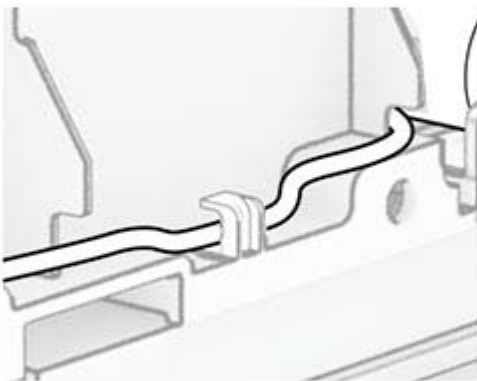
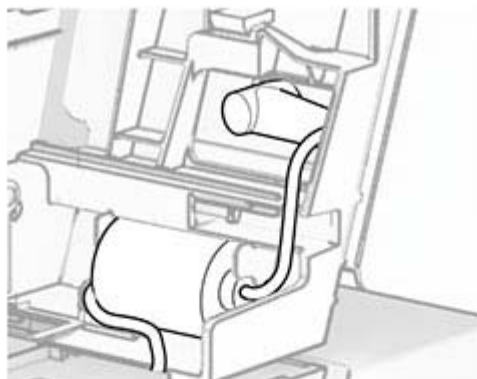

- 8** Attach the column cover.

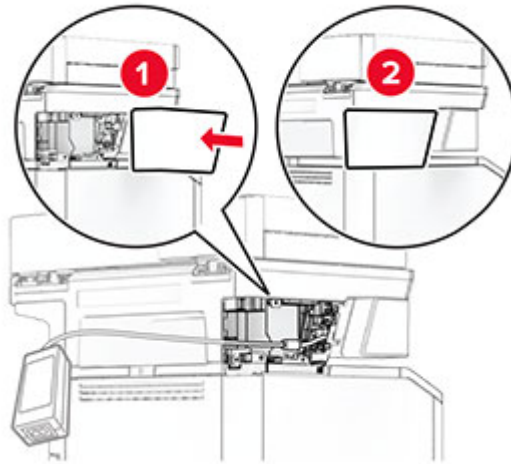

Note: Secure the power supply properly.



- 9** Connect one end of the stapler power cord to the power supply, and then the other end to the electrical outlet.
- 10** Connect one end of the printer power cord to the printer, and then the other end to the electrical outlet.
- ⚠ CAUTION—POTENTIAL INJURY:** To avoid the risk of fire or electrical shock, connect the power cord to an appropriately rated and properly grounded electrical outlet that is near the product and easily accessible.
- 11** Turn on the printer.

Networking

Connecting the printer to a Wi-Fi network

Make sure that Active Adapter is set to Auto. From the home screen, touch **Settings > Network/Ports > Network Overview > Active Adapter**.

- 1 From the home screen, touch **Settings > Network/Ports > Wireless > Setup On Printer Panel > Choose Network**.
- 2 Select a Wi-Fi network, and then type the network password.

Note: For Wi-Fi-network-ready printer models, a prompt for Wi-Fi network setup appears during initial setup.

Connecting the printer to a wireless network using Wi-Fi Protected Setup (WPS)

Before you begin, make sure that:

- The access point (wireless router) is WPS-certified or WPS-compatible. For more information, see the documentation that came with your access point.
- A wireless network adapter is installed in your printer. For more information, see the instructions that came with the adapter.
- Active Adapter is set to Auto. From the home screen, touch **Settings > Network/Ports > Network Overview > Active Adapter**.

Using the Push Button method

- 1 From the home screen, touch **Settings > Network/Ports > Wireless > Wi-Fi Protected Setup > Start Push Button Method**.
- 2 Follow the instructions on the display.

Using the personal identification number (PIN) method

- 1 From the home screen, touch **Settings > Network/Ports > Wireless > Wi-Fi Protected Setup > Start PIN Method**.
- 2 Copy the eight-digit WPS PIN.
- 3 Open a web browser, and then type the IP address of your access point in the address field.

Notes:

- To know the IP address, see the documentation that came with your access point.
 - If you are using a proxy server, then temporarily disable it to load the web page correctly.
- 4 Access the WPS settings. For more information, see the documentation that came with your access point.
 - 5 Enter the eight-digit PIN, and then save the changes.

Configuring Wi-Fi Direct

Wi-Fi Direct® is a Wi-Fi-based peer-to-peer technology that allows wireless devices to connect directly to a Wi-Fi Direct-enabled printer without using an access point (wireless router).

Make sure that Active Adapter is set to Auto. From the home screen, touch **Settings > Network/Ports > Network Overview > Active Adapter**.

- 1 From the home screen, touch **Settings > Network/Ports > Wi-Fi Direct**.
- 2 Configure the settings.
 - **Enable Wi-Fi Direct**—Enables the printer to broadcast its own Wi-Fi Direct network.
 - **Wi-Fi Direct Name**—Assigns a name for the Wi-Fi Direct network.
 - **Wi-Fi Direct Password**—Assigns the password for negotiating the wireless security when using the peer-to-peer connection.
 - **Show Password on Setup Page**—Shows the password on the Network Setup Page.
 - **Auto-Accept Push Button Requests**—Lets the printer accept connection requests automatically.

Note: Accepting push-button requests automatically is not secured.

Notes:

- By default, the Wi-Fi Direct network password is not visible on the printer display. To show the password, enable the password peek icon. From the home screen, touch **Settings > Security > Miscellaneous > Enable Password/PIN Reveal**.
- You can see the password of the Wi-Fi Direct network without showing it on the printer display. From the home screen, touch **Settings > Reports > Network > Network Setup Page**.

Connecting a mobile device to the printer

Before connecting your mobile device, make sure that Wi-Fi Direct has been configured. For more information, see [“Configuring Wi-Fi Direct” on page 72](#).

Connecting using Wi-Fi Direct

Note: These instructions apply only to Android mobile devices.

- 1 From the mobile device, go to the settings menu.
- 2 Enable **Wi-Fi**, and then tap **Wi-Fi Direct**.
- 3 Select the printer Wi-Fi Direct name.
- 4 Confirm the connection on the printer control panel.

Connecting using Wi-Fi

- 1 From the mobile device, go to the settings menu.
- 2 Tap **Wi-Fi**, and then select the printer Wi-Fi Direct name.

Note: The string DIRECT-xy (where x and y are two random characters) is added before the Wi-Fi Direct name.

- 3 Enter the Wi-Fi Direct password.

Connecting a computer to the printer

Before connecting your computer, make sure that Wi-Fi Direct has been configured. For more information, see [“Configuring Wi-Fi Direct” on page 72](#).

For Windows users

- 1 Open the printers folder, and then click **Add a printer or scanner**.
- 2 Click **Show Wi-Fi Direct printers**, and then select the printer Wi-Fi Direct name.
- 3 From the printer display, take note of the eight-digit PIN of the printer.
- 4 Enter the PIN on the computer.

Note: If the print driver is not already installed, then Windows downloads the appropriate driver.

For Macintosh users

- 1 Click the wireless icon, and then select the printer Wi-Fi Direct name.

Note: The string DIRECT-xy (where x and y are two random characters) is added before the Wi-Fi Direct name.

- 2 Type the Wi-Fi Direct password.

Note: Switch your computer back to its previous network after disconnecting from the Wi-Fi Direct network.

Deactivating the Wi-Fi network

- 1 From the home screen, touch **Settings > Network/Ports > Network Overview > Active Adapter > Standard Network**.
- 2 Follow the instructions on the display.

Checking the printer connectivity

- 1 From the home screen, touch **Settings > Reports > Network > Network Setup Page**.
- 2 Check the first section of the network setup page, and confirm that the status is connected.
If the status is not connected, then the LAN drop may be inactive, or the network cable may be malfunctioning. Contact your administrator for assistance.

Secure the printer

Locating the security slot

The printer is equipped with a security lock feature. Attach a security lock compatible with most laptop computers in the location shown to secure the printer in place.

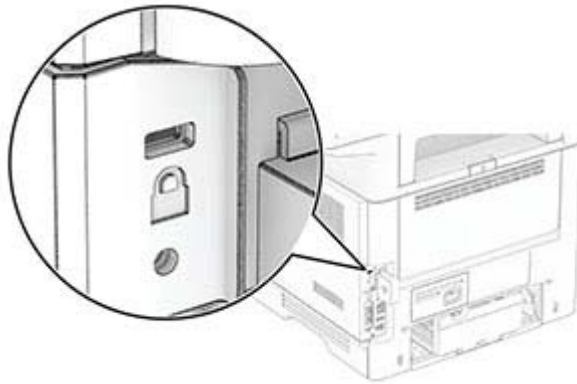

Erasing printer memory

To erase volatile memory or buffered data in your printer, turn off the printer.

To erase nonvolatile memory, device and network settings, security settings, and embedded solutions, do the following:

- 1 From the home screen, touch **Settings** > **Device** > **Maintenance** > **Out of Service Erase**.
- 2 Touch the **Sanitize all information on nonvolatile memory** check box, and then touch **ERASE**.
- 3 Touch **Start initial setup wizard** or **Leave printer offline**, and then touch **Next**.
- 4 Start the operation.

Note: This process also destroys the encryption key that is used to protect user data. Destroying the encryption key makes the data irrecoverable.

Erasing printer storage drive

- 1 From the home screen, touch **Settings** > **Device** > **Maintenance** > **Out of Service Erase**.
- 2 Depending on the storage drive that is installed on your printer, do either of the following:
 - For hard disk, touch the **Sanitize all information on hard disk** check box, touch **ERASE**, and then select a method to erase data.
Note: The process to sanitize the hard disk can take from several minutes to more than an hour, making the printer unavailable for other tasks.
 - For intelligent storage drive (ISD), touch **Erase Intelligent Storage Drive**, and then touch **ERASE** to erase all user data.
- 3 Start the operation.

Restoring factory default settings

- 1 From the home screen, touch **Settings** > **Device** > **Restore Factory Defaults**.
- 2 Touch **Restore Settings** > select the settings that you want to restore > **RESTORE**.
- 3 Start the operation.

Statement of Volatility

| Type of memory | Description |
|---------------------------------|---|
| Volatile memory | The printer uses standard random access memory (RAM) to buffer temporarily user data during simple print and copy jobs. |
| Nonvolatile memory | The printer may use two forms of non-volatile memory: EEPROM and NAND (flash memory). Both types store the operating system, printer settings, and network information. They also store scanner and bookmark settings and embedded solutions. |
| Hard disk storage drive | Some printers may have a hard disk drive installed. The printer hard disk is designed for printer-specific functionality. The hard disk lets the printer retain buffered user data from complex print jobs, form data, and font data. |
| Intelligent storage drive (ISD) | Some printers may have an ISD installed. ISD uses non-volatile flash memory to store user data from complex print jobs, form data, and font data. |

Erase the content of any installed printer memory in the following circumstances:

- The printer is decommissioned.
- The printer hard disk or ISD is replaced.
- The printer is moved to a different department or location.
- The printer is serviced by someone from outside your organization.
- The printer is removed from your premises for service.
- The printer is sold to another organization.

Note: To dispose a storage drive, follow the policies and procedures of your organization.

Print

Printing from a computer

Note: For labels, card stock, and envelopes, set the paper size and type in the printer before printing the document.

- 1 From the document that you are trying to print, open the Print dialog.
- 2 If necessary, adjust the settings.
- 3 Print the document.

Printing from a mobile device

Printing from a mobile device using AirPrint



The AirPrint software feature is a mobile printing solution that allows you to print directly from Apple devices to an AirPrint-certified printer.



Notes:

- Make sure that the Apple device and the printer are connected to the same network. If the network has multiple wireless hubs, then make sure that both devices are connected to the same subnet.
 - This application is supported only in some Apple devices.
- 1 From your mobile device, select a document from your file manager or launch a compatible application.
 - 2 Tap the share icon, and then tap **Print**.
 - 3 Select a printer.
If necessary, adjust the settings.
 - 4 Print the document.

Printing from a mobile device using Wi-Fi Direct®

Wi-Fi Direct® is a printing service that lets you print to any Wi-Fi Direct-ready printer.

Note: Make sure that the mobile device is connected to the printer wireless network. For more information, see [“Connecting a mobile device to the printer” on page 72](#).

- 1 From your mobile device, launch a compatible application or select a document from your file manager.
- 2 Depending on your mobile device, do one of the following:
 - Tap  > **Print**.
 - Tap  > **Print**.
 - Tap **...** > **Print**.
- 3 Select a printer, and then adjust the settings, if necessary.
- 4 Print the document.

Printing from a flash drive

- 1 Insert the flash drive.

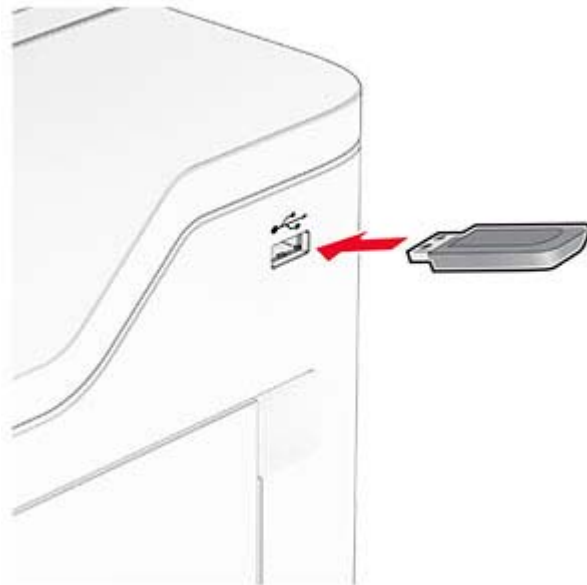

Notes:

- If you insert the flash drive when an error message appears, then the printer ignores the flash drive.
 - If you insert the flash drive while the printer is processing other print jobs, then **Busy** appears on the display.
- 2 From the display, touch the document that you want to print.
If necessary, configure the print settings.
 - 3 Print the document.
To print another document, touch **USB Drive**.

Warning—Potential Damage: To avoid loss of data or printer malfunction, do not touch the flash drive or the printer in the area shown while actively printing, reading, or writing from the memory device.



Supported flash drives and file types

Flash drives

- Flash drives that support USB 2.0 or lower.
- Flash drives that support a New Technology File System (NTFS) or the File Allocation Table (FAT32) file system.

File types

| Documents | Images |
|--|---|
| <ul style="list-style-type: none"> • PDF (version 1.7 or earlier) • Microsoft file formats (DOC, DOCX, XLS, XLSX, PPT, PPTX) | <ul style="list-style-type: none"> • JPEG or JPG • TIFF or TIF • GIF • BMP • PNG • PCX • DCX |

Configuring confidential jobs

- 1 From the home screen, touch **Settings** > **Security** > **Confidential Print Setup**.
- 2 Configure the settings.

| Setting | Description |
|-----------------------------|---|
| Max Invalid PIN | Set the limit for entering an invalid PIN. Note: When the limit is reached, the print jobs for that user name are deleted. |
| Confidential Job Expiration | Set an individual expiration time for each held job before it is automatically deleted from the printer memory, hard disk, or intelligent storage drive. Note: A held job is either Confidential, Repeat, Reserve, or Verify. |
| Repeat Job Expiration | Set the expiration time for print jobs that you want to repeat. |
| Verify Job Expiration | Set the expiration time for printing a copy of a job for you to check its quality before printing the remaining copies. |
| Reserve Job Expiration | Set the expiration time for jobs that you want to store in the printer for printing later. |
| Require All Jobs to be Held | Set the printer to hold all print jobs. |
| Keep duplicate documents | Set the printer to keep all documents with the same file name. |

Printing confidential and other held jobs

For Windows users

- 1 With a document open, click **File > Print**.
- 2 Select a printer, and then click **Properties, Preferences, Options, or Setup**.
- 3 Click **Print and Hold**.
- 4 Select **Use Print and Hold**, and then assign a user name.
- 5 Select the print job type (Confidential, Repeat, Reserve, or Verify).
If you select **Confidential**, then secure the print job with a personal identification number (PIN).
- 6 Click **OK** or **Print**.
- 7 From the printer home screen, release the print job.
 - For confidential print jobs, touch **Held jobs** > select your user name > **Confidential** > enter the PIN > select the print job > configure the settings > **Print**.
 - For other print jobs, touch **Held jobs** > select your user name > select the print job > configure the settings > **Print**.

For Macintosh users

Using AirPrint

- 1 With a document open, choose **File > Print**.
- 2 Select a printer, and then from the drop-down menu following the Orientation menu, choose **PIN Printing**.
- 3 Enable **Print with PIN**, and then enter a four-digit PIN.

- 4 Click **Print**.
- 5 From the printer home screen, release the print job. Touch **Held jobs** > select your computer name > **Confidential** > enter the PIN > select the print job > **Print**.

Using the print driver

- 1 With a document open, choose **File** > **Print**.
- 2 Select a printer, and then from the drop-down menu following the Orientation menu, choose **Print and Hold**.
- 3 Choose **Confidential Print**, and then enter a four-digit PIN.
- 4 Click **Print**.
- 5 From the printer home screen, release the print job. Touch **Held jobs** > select your computer name > **Confidential** > select the print job > enter the PIN > **Print**.

Printing a font sample list

- 1 From the home screen, touch **Settings** > **Reports** > **Print** > **Print Fonts**.
- 2 Touch **PCL Fonts** or **PS Fonts**.

Printing a directory list

From the home screen, touch **Settings** > **Reports** > **Print** > **Print Directory**.

Placing separator sheets between copies

- 1 From the home screen, touch **Settings** > **Print** > **Layout** > **Separator Sheets** > **Between Copies**.
- 2 Print the document.

Canceling a print job

- 1 From the home screen, touch .
- 2 Select the job to cancel.



Note: You can also cancel a job by touching **Job Queue**.

Adjusting toner darkness

- 1 From the home screen, touch **Settings** > **Print** > **Quality** > **Toner Darkness**.
- 2 Adjust the setting.

Copy

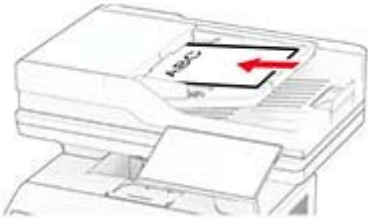
Using the automatic document feeder and scanner glass

| Automatic document feeder (ADF) | Scanner glass |
|---|--|
|  <ul style="list-style-type: none"> • Use the ADF for multiple-page or two-sided documents. • Load an original document faceup. For multiple-page documents, make sure to align the leading edge before loading. • Make sure to adjust the ADF guides to match the width of the paper that you are loading. |  <ul style="list-style-type: none"> • Use the scanner glass for single-page documents, book pages, small items (such as postcards or photos), transparencies, photo paper, or thin media (such as magazine clippings). • Place the document facedown in the corner with the arrow. |

Making copies

- 1 Load an original document into the ADF tray or on the scanner glass.

Note: To avoid a cropped image, make sure that the original document and output have the same paper size.

- 2 From the home screen, touch **Copy**, and then specify the number of copies.
If necessary, adjust the copy settings.
- 3 Copy the document.

Note: To make a quick copy, from the home screen, touch .

Copying photos

- 1 Place a photo on the scanner glass.
- 2 From the home screen, touch **Copy** > **Settings** > **Content** > **Content Type** > **Photo**.
- 3 Touch **Content Source**, and then select the setting that best matches the original photo.
- 4 Copy the photo.

Copying on letterhead

- 1 Load an original document into the ADF tray or on the scanner glass.
- 2 From the home screen, touch **Copy** > **Copy From** > select the size of the original document.
- 3 Touch **Copy To**, and then select the paper source that contains the letterhead.
If you loaded the letterhead into the multipurpose feeder, then touch **Copy To** > **Multipurpose Feeder** > select a paper size > **Letterhead**.
- 4 Copy the document.

Copying on both sides of the paper

- 1 Load an original document into the ADF tray or on the scanner glass.
- 2 From the home screen, touch **Copy** > **Settings** > **Sides**.
- 3 Touch **1 sided to 2 sided** or **2 sided to 2 sided**.
- 4 Copy the document.

Reducing or enlarging copies

- 1 Load an original document into the ADF tray or on the scanner glass.
- 2 From the home screen, touch **Copy** > **Settings** > **Scale** > select a scale value.
Note: Changing the size of the original document or output after setting Scale restores the scale value to Auto.
- 3 Copy the document.

Collating copies

- 1 Load an original document into the ADF tray or on the scanner glass.
- 2 From the home screen, touch **Copy** > **Collate** > **On [1,2,1,2,1,2]**.
- 3 Copy the document.

Placing separator sheets between copies

- 1 Load an original document into the ADF tray or on the scanner glass.
- 2 From the control panel, navigate to:
Copy > **Settings** > **Separator Sheets** > adjust the settings
- 3 Copy the document.

Copying multiple pages onto a single sheet

- 1 Load an original document into the ADF tray or on the scanner glass.
- 2 From the home screen, touch **Copy** > **Settings** > **Pages per Side**.
- 3 Enable the setting, and then select the number per side and page orientation.
- 4 Copy the document.

Copying cards

- 1 Load a card on the scanner glass.
- 2 From the home screen, touch **Card Copy**.
Note: If necessary, adjust the scan settings.
- 3 Touch **Scan**.



Note: If you want multiple copies of the card, then touch **Print a Copy**.

Creating a copy shortcut

- 1 From the home screen, touch **Copy**.
- 2 Configure the settings, and then touch .
- 3 Create a shortcut.

E-mail

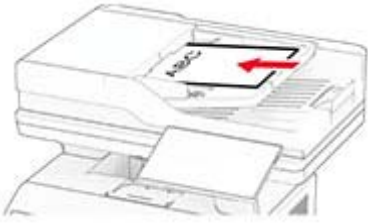
Using the automatic document feeder and scanner glass

| Automatic document feeder (ADF) | Scanner glass |
|---|--|
|  <ul style="list-style-type: none"> • Use the ADF for multiple-page or two-sided documents. • Load an original document faceup. For multiple-page documents, make sure to align the leading edge before loading. • Make sure to adjust the ADF guides to match the width of the paper that you are loading. |  <ul style="list-style-type: none"> • Use the scanner glass for single-page documents, book pages, small items (such as postcards or photos), transparencies, photo paper, or thin media (such as magazine clippings). • Place the document facedown in the corner with the arrow. |

Sending an e-mail

Before you begin, make sure that the SMTP settings are configured. For more information, see [“Configuring the e-mail SMTP settings” on page 33](#).



- 1 Load an original document into the ADF tray or on the scanner glass.
- 2 From the home screen, touch **E-mail**, and then enter the needed information.
- 3 If necessary, configure the scan settings.
- 4 Send the e-mail.

Creating an e-mail shortcut

- 1 From the home screen, touch **E-mail**.
- 2 Configure the settings, and then touch .
- 3 Create a shortcut.

Fax

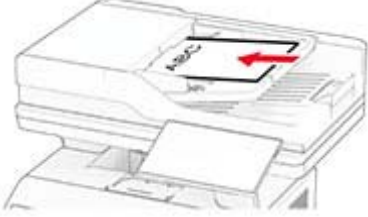
Using the automatic document feeder and scanner glass

| Automatic document feeder (ADF) | Scanner glass |
|---|--|
|  <ul style="list-style-type: none"> • Use the ADF for multiple-page or two-sided documents. • Load an original document faceup. For multiple-page documents, make sure to align the leading edge before loading. • Make sure to adjust the ADF guides to match the width of the paper that you are loading. |  <ul style="list-style-type: none"> • Use the scanner glass for single-page documents, book pages, small items (such as postcards or photos), transparencies, photo paper, or thin media (such as magazine clippings). • Place the document facedown in the corner with the arrow. |

Sending a fax

Note: Make sure that fax is configured. For more information, see the [Setting up the printer to fax](#) section.

Using the control panel

- 1 Load an original document into the ADF tray or on the scanner glass.
- 2 From the home screen, touch **Fax**, and then enter the needed information.
If necessary, adjust the settings.
- 3 Send the fax.

Using the computer

Before you begin, make sure that the fax driver is installed. For more information, see [“Installing the fax driver” on page 45](#).

For Windows users

- 1 From the document that you are trying to fax, open the Print dialog.
- 2 Select the printer, and then click **Properties**, **Preferences**, **Options**, or **Setup**.

- 3 Click **Fax** > **Enable fax** > **Always display settings prior to faxing**, and then enter the recipient number.
If necessary, configure other fax settings.
- 4 Send the fax.

For Macintosh users

- 1 With a document open, choose **File** > **Print**.
- 2 Select the printer that has - **Fax** added after its name.
- 3 In the To field, enter the recipient number.
If necessary, configure other fax settings.
- 4 Send the fax.

Scheduling a fax

Note: Make sure that fax is configured. For more information, see the [Setting up the printer to fax](#) section.

- 1 Load an original document into the ADF tray or on the scanner glass.
- 2 From the home screen, touch **Fax** > **To** > enter the fax number > **Done**.
- 3 Touch **Send Time**, configure the date and time, and then touch **Done**.
- 4 Send the fax.

Creating a fax destination shortcut

Note: Make sure that fax is configured. For more information, see the [Setting up the printer to fax](#) section.

- 1 From the home screen, touch **Fax** > **To**.
- 2 Enter the recipient number, and then touch **Done**.
- 3 Configure the settings, and then touch .
- 4 Create a shortcut.

Changing the fax resolution

Note: Make sure that fax is configured. For more information, see the [Setting up the printer to fax](#) section.

- 1 Load an original document into the ADF tray or on the scanner glass.
- 2 From the home screen, touch **Fax**, and then enter the needed information.
- 3 Touch **Settings** > **Resolution** > select a setting.
- 4 Send the fax.

Adjusting the fax darkness

Note: Make sure that fax is configured. For more information, see the [Setting up the printer to fax](#) section.

- 1 Load an original document into the ADF tray or on the scanner glass.
- 2 From the home screen, touch **Fax**, and then enter the needed information.
- 3 Touch **Settings** > **Darkness** > adjust the setting.
- 4 Send the fax.

Printing a fax log

Note: Make sure that fax is configured. For more information, see the [Setting up the printer to fax](#) section.

- 1 From the home screen, touch **Settings** > **Reports** > **Fax**.
- 2 Touch **Fax Job Log** or **Fax Call Log**.

Blocking junk faxes

Note: Make sure that fax is configured. For more information, see the [Setting up the printer to fax](#) section.

- 1 From the home screen, touch **Settings** > **Fax** > **Fax Setup** > **Fax Receive Settings** > **Admin Controls**.
- 2 Set Block No Name Fax to **On**.

Holding faxes

Note: Make sure that fax is configured. For more information, see the [Setting up the printer to fax](#) section.

- 1 From the home screen, touch **Settings** > **Fax** > **Fax Setup** > **Fax Receive Settings** > **Holding Faxes**.
- 2 Select a mode.

Forwarding a fax

Note: Make sure that fax is configured. For more information, see the [Setting up the printer to fax](#) section.

- 1 Create a destination shortcut.
 - a Open a web browser, and then type the printer IP address in the address field.

Notes:

- View the printer IP address on the home screen. The IP address appears as four sets of numbers separated by periods, such as 123.123.123.123.
- If you are using a proxy server, then temporarily disable it to load the web page correctly.

- b Click **Shortcuts** > **Add Shortcut**.

c Select a shortcut type, and then configure the settings.

Note: Take note of the shortcut number.

d Apply the changes.

2 Click **Settings > Fax > Fax Setup > Fax Receive Settings > Admin Controls**.



3 In the Fax Forwarding menu, select **Forward** or **Print and Forward**.

4 In the Forward to menu, select the destination type and then type the shortcut number.

5 Apply the changes.

Scan

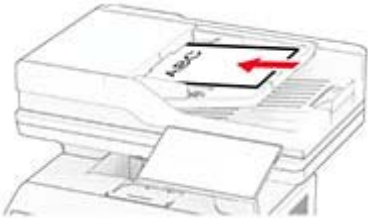
Using the automatic document feeder and scanner glass

| Automatic document feeder (ADF) | Scanner glass |
|---|---|
|  <ul style="list-style-type: none">• Use the ADF for multiple-page or two-sided documents.• Load an original document faceup. For multiple-page documents, make sure to align the leading edge before loading.• Make sure to adjust the ADF guides to match the width of the paper that you are loading. |  <ul style="list-style-type: none">• Use the scanner glass for single-page documents, book pages, small items (such as postcards or photos), transparencies, photo paper, or thin media (such as magazine clippings).• Place the document facedown in the corner with the arrow. |

Scanning to a computer

Before you begin, make sure that the computer and the printer are connected to the same network.

For Windows users

Note: Make sure that the printer is added to the computer. For more information, see [“Adding printers to a computer” on page 45](#).

- 1 Load an original document into the automatic document feeder or on the scanner glass.
- 2 From the computer, open **Windows Fax and Scan**.
- 3 Click **New Scan**, and then select a scanner source.
- 4 If necessary, change the scan settings.
- 5 Scan the document.
- 6 Click **Save as**, type a file name, and then click **Save**.

For Macintosh users

Note: Make sure that the printer is added to the computer. For more information, see [“Adding printers to a computer” on page 45](#).

- 1 Load an original document into the automatic document feeder or on the scanner glass.
- 2 From the computer, do either of the following:
 - Open **Image Capture**.
 - Open **Printers & Scanners**, and then select a printer. Click **Scan** > **Open Scanner**.
- 3 From the Scanner window, do one or more of the following:
 - Select the location that you want to save the scanned document.
 - Select the size of the original document.
 - To scan from the ADF, select **Document Feeder** from the Scan Menu or enable **Use Document Feeder**.
 - If necessary, configure the scan settings.
- 4 Click **Scan**.

Scanning to an FTP server

- 1 Load the original document into the ADF tray or on the scanner glass.
- 2 From the home screen, touch **FTP**, and then enter the needed information.
- 3 If necessary, configure other FTP settings.
- 4 Send the FTP job.

Creating an FTP shortcut

- 1 From the home screen, touch **FTP**.
- 2 Enter the FTP server address, and then touch .
- 3 Create a shortcut.

Scanning to a network folder

- 1 Load the document into the ADF tray or on the scanner glass.
- 2 From the home screen, touch **Scan Center**.

Note: The icon and name may have been changed. For more information, contact your administrator.
- 3 Do either of the following:
 - Select a destination.

Note: For SFTP, set the port number to **22**.
 - Use a shortcut by touching , and then selecting the shortcut from the list.
- 4 Scan the document.

Creating a network folder shortcut

- 1 Open a web browser, and then type the printer IP address in the address field.

Notes:

- View the printer IP address on the printer home screen. The IP address appears as four sets of numbers separated by periods, such as 123.123.123.123.
- If you are using a proxy server, then temporarily disable it to load the web page correctly.

- 2 Click **Shortcuts > Add Shortcut**.
- 3 From the Shortcut Type menu, select **Network Folder**, and then configure the settings.
- 4 Apply the changes.

Scanning to a flash drive

- 1 Load an original document into the ADF tray or on the scanner glass.
- 2 Insert the flash drive.

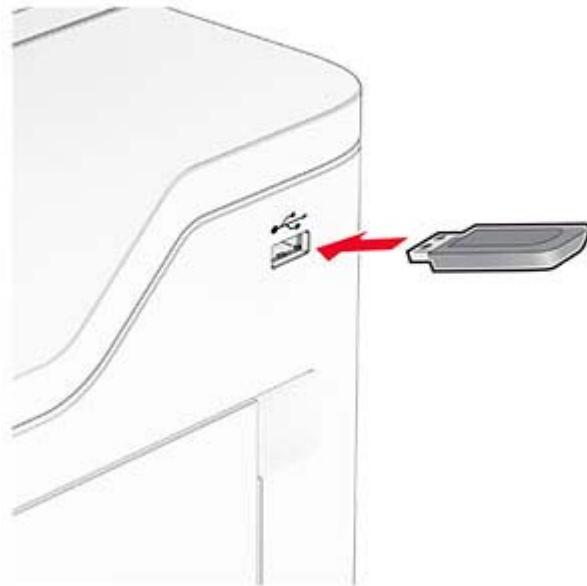

- 3 Touch **Scan to USB** and adjust the settings if necessary.

Notes:

- To save the scanned document to a folder, touch **Scan to**, select a folder, and then touch **Scan Here**.
- If the USB Drive screen does not appear, then touch **USB Drive** on the control panel.

- 4 Scan the document.

Warning—Potential Damage: To avoid loss of data or printer malfunction, do not touch the flash drive or the printer in the area shown while actively printing, reading, or writing from the memory device.



Use printer menus

Menu map

| | | |
|---------------|--|--|
| Device | <ul style="list-style-type: none"> • Preferences • Eco-Mode • Remote Operator Panel • Notifications • Power Management • Anonymous Data Collection | <ul style="list-style-type: none"> • Accessibility • Restore Factory Defaults • Maintenance • Home Screen Customization¹ • Update Firmware • About this Printer |
| Print | <ul style="list-style-type: none"> • Layout • Setup • Quality • Job Accounting | <ul style="list-style-type: none"> • PDF • PostScript • PCL • Image |
| Paper | <ul style="list-style-type: none"> • Tray Configuration | <ul style="list-style-type: none"> • Media Configuration |
| Copy | Copy Defaults | |
| Fax | Fax Defaults | |
| E-mail | <ul style="list-style-type: none"> • E-mail Setup • E-mail Defaults | <ul style="list-style-type: none"> • Web Link Setup |
| FTP | FTP Defaults | |
| USB Drive | <ul style="list-style-type: none"> • Flash Drive Scan | <ul style="list-style-type: none"> • Flash Drive Print |
| Network/Ports | <ul style="list-style-type: none"> • Network Overview • Wireless • Wi-Fi Direct • AirPrint • Mobile Services Management • Ethernet • TCP/IP • SNMP | <ul style="list-style-type: none"> • IPSec • 802.1x • LPD Configuration • HTTP/FTP Settings • ThinPrint • USB • Restrict external network access |
| Security | <ul style="list-style-type: none"> • Login Methods • Schedule USB Devices • Security Audit Log • Login Restrictions • Confidential Print Setup | <ul style="list-style-type: none"> • Disk Encryption • Erase Temporary Data Files • Solutions LDAP Settings • Miscellaneous |
| Reports | <ul style="list-style-type: none"> • Menu Settings Page • Device • Print | <ul style="list-style-type: none"> • Shortcuts • Fax • Network |

¹ Appears only in the Embedded Web Server.

² Appears only when a hard disk or an intelligent storage drive is installed.

| | | |
|---|-----------------------------|----------------------|
| Troubleshooting | Print Quality Test Pages | Cleaning the Scanner |
| Forms Merge² | Forms Merge | |
| ¹ Appears only in the Embedded Web Server. ² Appears only when a hard disk or an intelligent storage drive is installed. | | |

Device

Preferences

| Menu item | Description |
|---|--|
| Display Language [List of languages] | Set the language of the text that appears on the display. |
| Country/Region [List of countries or regions] | Identify the country or region where the printer is configured to operate. |
| Run initial setup Off* On | Run the setup wizard. |
| Keyboard Keyboard Type [List of languages] | Select a language as a keyboard type. Note: All the Keyboard Type values may not appear or may require special hardware to appear. |
| Displayed information Display Text 1 (IP Address*) Display Text 2 (Date/Time*) Custom Text 1 Custom Text 2 | Specify the information to appear on the home screen. |
| Note: An asterisk (*) next to a value indicates the factory default setting. | |

| Menu item | Description |
|--|--|
| <p>Date and Time</p> <ul style="list-style-type: none"> Configure <ul style="list-style-type: none"> Current Date and Time Manually Set Date and Time Date Format (MM-DD-YYYY*) Time Format (12 hour A.M./P.M.*) Time Zone UTC (GMT) Offset DST Start DST End DST Offset Network Time Protocol <ul style="list-style-type: none"> Enable NTP (On*) NTP Server Enable Authentication (None*) Key ID Password | <p>Configure the printer date and time and network time protocol.</p> <p>Notes:</p> <ul style="list-style-type: none"> MM-DD-YYYY is the U.S. factory default setting. DD-MM-YYYY is the international factory default setting. UTC (GMT) Offset, DST Start, DST End, and DST Offset appear only when Time Zone is set to (UTC+user) Custom. Key ID and Password appear only when Enable Authentication is set to MD5 key. |
| <p>Paper Sizes</p> <ul style="list-style-type: none"> U.S.* Metric | <p>Specify the unit of measurement for paper sizes.</p> <p>Note: The country or region selected in the initial setup wizard determines the initial paper size setting.</p> |
| <p>Screen Brightness</p> <p>20–100% (100*)</p> | <p>Adjust the brightness of the display.</p> |
| <p>Flash Drive Access</p> <ul style="list-style-type: none"> Disabled Enabled* | <p>Enable access to the flash drive.</p> |
| <p>Allow Background Removal</p> <ul style="list-style-type: none"> Off On* | <p>Specify whether background removal is allowed.</p> |
| <p>Allow Custom Job scans</p> <ul style="list-style-type: none"> Off On* | <p>Specify whether the Custom Job Scanning setting appears for copy, scan, and fax.</p> <p>Note: This menu item appears only when a hard disk or an intelligent storage drive is installed.</p> |
| <p>One Page Flatbed Scanning</p> <ul style="list-style-type: none"> Off* On | <p>Set the printer to scan any type of job involving the scanner glass as a single page.</p> <p>Note: The printer returns to the home screen after performing a single flatbed scan instead of displaying prompts.</p> |
| <p>Note: An asterisk (*) next to a value indicates the factory default setting.</p> | |

| Menu item | Description |
|--|---|
| Device Sounds Mute All Sounds (Off*) Button Feedback (On*) Volume (5*) ADF Loaded Beep (On*) Alarm Control (Single*) Cartridge Alarm (Off*) Speaker Mode (Always Off*) Ringer Volume (Off*) | Configure the sound settings of the printer. |
| Screen Timeout 5–300 seconds (60*) | Set the idle time in seconds before the display shows the home screen, or before the printer logs out a user account automatically. |
| Note: An asterisk (*) next to a value indicates the factory default setting. | |

Eco-Mode

| Menu item | Description |
|--|---|
| Print Sides 1-Sided* 2-Sided | Specify whether to print on one side or two sides of the paper. |
| Print Pages per Side Off* 2 pages per side 3 pages per side 4 pages per side 6 pages per side 9 pages per side 12 pages per side 16 pages per side | Print multiple page images on one side of a sheet of paper. |
| Print Toner Darkness 1–10 (8*) | Determine the lightness or darkness of text images. |
| Copy Sides 1 sided to 1 sided* 1 sided to 2 sided 2 sided to 1 sided 2 sided to 2 sided | Specify the scanning behavior based on the original document. |
| Note: An asterisk (*) next to a value indicates the factory default setting. | |

| Menu item | Description |
|---|---|
| Copy Pages per Side Off* 2 Portrait pages 4 Portrait pages 2 Landscape pages 4 Landscape pages | Specify the scanning behavior based on the original document. |
| Copy Darkness 1–9 (5*) | Determine the darkness of the scanned text images. |
| Note: An asterisk (*) next to a value indicates the factory default setting. | |

Remote Operator Panel

| Menu item | Description |
|---|---|
| External VNC Connection Don't Allow* Allow | Connect an external Virtual Network Computing (VNC) client to the remote control panel. |
| Authentication Type None* Standard Authentication | Set the authentication type when accessing the VNC client server. |
| VNC Password | Specify the password to connect to the VNC client server. Note: This menu item appears only if Authentication Type is set to Standard Authentication. |
| Note: An asterisk (*) next to a value indicates the factory default setting. | |

Notifications

| Menu item | Description |
|--|--|
| ADF Loaded Beep Off On* | Enable a sound when loading paper into the ADF. |
| Alarm Control Off Single* Continuous | Set the number of times that the alarm sounds when the printer requires user intervention. |
| Supplies Show Supply Estimates Show estimates* Do not show estimates | Show the estimated status of the supplies. |
| Note: An asterisk (*) next to a value indicates the factory default setting. | |

| Menu item | Description |
|---|--|
| Supplies Cartridge Alarm Off* Single Continuous | Set the number of times that the alarm sounds when the toner cartridge is low. |
| Supplies Custom Supply Notifications | Configure notification settings when the printer requires user intervention. Note: This menu item appears only in the Embedded Web Server. |
| E-mail Alerts Setup Primary SMTP Gateway Primary SMTP Gateway Port (25*) Secondary SMTP Gateway Secondary SMTP Gateway Port (25*) SMTP Timeout (30 seconds*) Reply Address Always use SMTP default Reply Address (Off*) Use SSL/TLS (Disabled*) Require Trusted Certificate (On*) SMTP Server Authentication (No authentication required*) Device-Initiated E-mail (None*) User-Initiated E-mail (None*) Use Active Directory Device Credentials (Off*) Device Userid Device Password Kerberos 5 REALM NTLM Domain Disable "SMTP server not set up" error (Off*) | Configure the printer to send e-mail alerts to a list of contacts when the printer requires user intervention. |
| E-mail Alerts Setup Setup E-mail Lists and Alerts E-mail List 1 E-mail List 2 Subject Text E-mail Events | Specify the e-mail addresses and enable the e-mail alert events. Note: This menu item appears only in the Embedded Web Server. |
| Error Prevention Jam Assist Off On* | Set the printer to flush automatically blank pages or pages with partial prints after a jammed page is cleared. |
| Note: An asterisk (*) next to a value indicates the factory default setting. | |

| Menu item | Description |
|---|--|
| Error Prevention Auto Continue Enabled 5–255 (5*) | Let the printer to continue processing or printing a job automatically after clearing certain attendance conditions. |
| Error Prevention Auto Reboot Auto Reboot Reboot when idle Reboot always* Reboot never | Set the printer to restart when an error occurs. |
| Error Prevention Auto Reboot Max Auto Reboots 1–20 (2*) | Set the number of automatic reboots that the printer can perform. |
| Error Prevention Auto Reboot Auto Reboot Window 1–525600 (720*) | Set the number of seconds before the printer performs an automatic reboot. |
| Error Prevention Auto Reboot Auto Reboot Counter | Show a read-only information of the reboot counter. |
| Error Prevention Auto Reboot Reset Auto Reboot Counter Cancel Continue | Reset the values of the Auto Reboot Counter. |
| Error Prevention Display Short Paper Error On Auto-clear* | Set the printer to show a message when a short paper error occurs. Note: Short paper refers to the size of the paper loaded. |
| Error Prevention Page Protect Off* On | Set the printer to process the entire page into the memory before printing it. |
| Jam Content Recovery Jam Recovery Off On Auto* | Set the printer to reprint jammed pages. |
| Note: An asterisk (*) next to a value indicates the factory default setting. | |

| Menu item | Description |
|---|--|
| Jam Content Recovery Scanner Jam Recovery Job level Page level* | Specify how to restart a scan job after resolving a paper jam. |
| Note: An asterisk (*) next to a value indicates the factory default setting. | |

Power Management

| Menu item | Description |
|---|---|
| Sleep Mode Profile Print from Sleep Mode Stay awake after printing Enter Sleep Mode after printing* | Set the printer to stay awake or enter Sleep mode after printing. |
| Sleep Mode Profile Touch to Wake from Deep Sleep Off On* | Wake the printer from Deep Sleep mode by touching the printer display. |
| Timeouts Sleep Mode 1–114 minutes (15*) | Set the idle time before the printer begins operating in Sleep mode. |
| Timeouts Hibernate Timeout Disabled 1 hour 2 hours 3 hours 6 hours 1 day 2 days 3 days* 1 week 2 weeks 1 month | Set the time before the printer turns off. |
| Timeouts Hibernate Timeout on Connection Hibernate Do Not Hibernate* | Set Hibernate Timeout to turn off the printer while an active Ethernet connection exists. |
| Schedule Power Modes Schedules Add New Schedule | Schedule the printer when to enter Sleep or Hibernate mode. |
| Note: An asterisk (*) next to a value indicates the factory default setting. | |

Anonymous Data Collection

| Menu item | Description |
|---|---|
| Anonymous Data Collection Device Usage and Performance Information None* | Send printer usage and performance information to the manufacturer. Note: Anonymous Data Send Time appears only when you set Anonymous Data Collection to Device Usage and Performance Information. |
| Anonymous Data Send Time Start Time Stop Time | |
| Note: An asterisk (*) next to a value indicates the factory default setting. | |

Accessibility

| Menu item | Description |
|---|--|
| Duplicate Key Strike Interval 0–5 (0*) | Set the interval in seconds during which the printer ignores duplicate key presses on an attached keyboard. |
| Key Repeat Initial Delay 0.25–5 (1*) | Set the initial length of delay in seconds before a repeating key starts repeating. |
| Key Repeat Rate 0.5–30 (30*) | Set the number of presses per second for a repeating key. |
| Prolong Screen Timeout Off* On | Let the user remain in the same location and reset the Screen Timeout timer when it expires instead of returning to the home screen. |
| Headphone Volume 1–10 (5*) | Adjust the headphone volume. |
| Enable Voice Guidance When Headphone Is Attached Off* On | Enable Voice Guidance when a headphone is attached to the printer. |
| Speak Passwords/PINs Off* On | Set the printer to read out loud passwords or personal identification numbers. |
| Note: An asterisk (*) next to a value indicates the factory default setting. | |

| Menu item | Description |
|---|-------------------------------------|
| Speech Rate Very Slow Slow Normal* Fast Faster Very Fast Rapid Very Rapid Fastest | Set the Voice Guidance speech rate. |
| Note: An asterisk (*) next to a value indicates the factory default setting. | |

Restore Factory Defaults

| Menu item | Description |
|---|---|
| Restore Settings Restore all settings Restore printer settings Restore network settings Restore fax settings Restore app settings | Restore the printer factory default settings. |

Maintenance

Configuration Menu

| Menu item | Description |
|---|--|
| USB Configuration USB PnP 1* 2 | Change the USB driver mode of the printer to improve its compatibility with a personal computer. |
| USB Configuration USB Scan to Local On* Off | Set whether the USB device driver enumerates as a USB Simple device (single interface) or as a USB Composite device (multiple interfaces). |
| USB Configuration USB Speed Full Auto* | Set the USB port to run at full speed and disable its high-speed capabilities. |
| Note: An asterisk (*) next to a value indicates the factory default setting. | |

| Menu item | Description |
|---|--|
| Tray Configuration Tray Linking Automatic* Off | Set the printer to link the trays that have the same paper type and paper size settings. |
| Tray Configuration Show Tray Insert Message Off Only for unknown sizes* Always | Display a message that lets the user change the paper size and paper type settings after inserting the tray. |
| Tray Configuration A5 Loading Short Edge* Long Edge | Determine the default loading orientation for the A5 size paper in all paper sources. |
| Tray Configuration Paper Prompts Auto* Multipurpose Feeder Manual Paper | Set the paper source that the user fills when a prompt to load paper appears. Note: For Multipurpose Feeder to appear, in the Paper menu, set Configure MP to Cassette. |
| Tray Configuration Envelope Prompts Auto* Multipurpose Feeder Manual Envelope | Set the paper source that the user fills when a prompt to load envelope appears. Note: For Multipurpose Feeder to appear, in the Paper menu, set Configure MP to Cassette. |
| Tray Configuration Action for Prompts Prompt user* Continue Use current | Set the printer to resolve paper- or envelope-related change prompts. |
| Tray Configuration Multiple Universal Sizes Off* On | Set the tray to support multiple universal paper sizes. |
| Reports Menu Settings Page Event Log Event Log Summary | Print reports about printer menu settings, status, and event logs. |
| Supply Usage And Counters Clear Supply Usage History | Reset the supply usage history, such as number of pages and days remaining, to the factory shipped level. |
| Supply Usage And Counters Reset Maintenance Counter | Reset the counter after installing a new maintenance kit. |
| Note: An asterisk (*) next to a value indicates the factory default setting. | |

| Menu item | Description |
|--|--|
| Printer Emulations PPDS Emulation Off* On | Set the printer to recognize and use the PPDS data stream. |
| Printer Emulations PS Emulation Off On* | Set the printer to recognize and use the PS data stream. |
| Printer Emulations Use Native ISD Fonts Off* On | Let the printer use the native or free fonts in the intelligent storage drive (ISD) for printing. |
| Printer Emulations Enable Formsmerge Off On* | Activate Forms Merge to store the forms into the hard disk or ISD. Notes: <ul style="list-style-type: none"> • The Forms Merge license must be installed. • This menu item appears only when a hard disk or an ISD is installed. |
| Printer Emulations Enable Prescribe Off* On | Activate Prescribe. Note: The Prescribe license must be installed. |
| Printer Emulations Emulator Security Page Timeout 0–60 (60*) | Set the page time-out during emulation. |
| Printer Emulations Emulator Security Reset Emulator After Job Off* On | Reset the emulator after a print job. |
| Printer Emulations Emulator Security Disable Printer Message Access Off On* | Disable access to printer message during emulation. |
| Fax Configuration Fax Low Power Support Disable Sleep Permit Sleep Auto* | Set fax to enter Sleep mode whenever the printer determines that it must. |
| Note: An asterisk (*) next to a value indicates the factory default setting. | |

| Menu item | Description |
|--|---|
| Fax Configuration Fax Storage Location NAND Disk* | Set the storage location for all faxes. Note: This menu item appears only when an ISD is installed. |
| Print Configuration Font Sharpening 0–150 (24*) | Set a text point-size value below which the high-frequency screens are used when printing font data. For example, if the value is 24, then all fonts sized 24 points or less use the high-frequency screens. |
| Print Configuration Print Density Disabled 1–5 (3*) | Adjust the toner density when printing documents. |
| Print Configuration Copy Density Disabled 1–5 (3*) | Adjust the toner density when copying documents. |
| Device Operations Quiet Mode Off* On | Set the printer to operate in Quiet Mode. Note: Enabling this setting slows down the overall performance of the printer. |
| Device Operations Safe Mode Off* On | Set the printer to operate in a special mode, in which it attempts to continue offering as much functionality as possible, despite known issues. For example, when set to On, and the duplex motor is nonfunctional, the printer performs one-sided printing of the documents even if the job is two-sided printing. |
| Device Operations Minimum Copy Memory 20 MB* 30 MB 50 MB 80 MB 100 MB | Set the minimum memory allocation for storing copy jobs. |
| Device Operations Clear Custom Status | Erase user-defined strings for the Default or Alternate custom messages. |
| Device Operations Clear all remotely-installed messages | Erase messages that were remotely installed. |
| Device Operations Automatically Display Error Screens Off On* | Show existing error messages on the display after the printer remains inactive on the home screen for a length of time. |
| Note: An asterisk (*) next to a value indicates the factory default setting. | |

| Menu item | Description |
|--|--|
| Device Operations Honor orientation on fast path copy Off* On | Enable the printer to use the orientation setting under the Copy menu when sending quick copy jobs. |
| Scanner Configuration Scanner Manual Registration Print Quick Test | Print a Quick Test target page. Note: Make sure that the margin spacing on the target page is uniform all the way around the target. If it is not, then the printer margins must be reset. |
| Scanner Configuration Scanner Manual Registration Front ADF Registration Rear ADF Registration Flatbed Registration | Manually register the flatbed and ADF after replacing the ADF, scanner glass, or controller board. |
| Scanner Configuration Reset Maintenance Counter | Reset the counter after replacing the ADF maintenance kit. |
| Scanner Configuration Edge Erase Flatbed Edge Erase (3*) ADF Edge Erase (3*) | Set the size, in millimeters, of the no-print area around an ADF or flatbed scan job. |
| Scanner Configuration Disable Scanner No* Yes ADF Only | Disable the scanner when it is not working properly. |
| Scanner Configuration Tiff Byte Order CPU Endianness* Little Endian Big Endian | Set the byte order of a TIFF-formatted scan output. |
| Scanner Configuration Exact Tiff Rows Per Strip On* Off | Set the RowsPerStrip tag value of a TIFF-formatted scan output. |
| Note: An asterisk (*) next to a value indicates the factory default setting. | |

Out of Service Erase

| Menu item | Description |
|---|---|
| Out of Service Erase Memory Last Sanitized Hard Disk Last Sanitized ISD last erased | Show a read-only information on when the printer memory or storage drive was last erased. Note: Hard Disk Last Sanitized and ISD last erased appear only when a storage drive is installed. |

| Menu item | Description |
|--|--|
| Out of Service Erase Sanitize all information on nonvolatile memory Erase all printer and network settings Erase all apps and app settings Erase all shortcuts and shortcut settings Sanitize all information on hard disk Erase downloads (Erase all macros, fonts, PFOs, etc.) Erase buffered jobs Erase Held jobs Erase Intelligent Storage Drive | Clear all information on nonvolatile memory and on the storage drive. Note: Sanitize all information on hard disk and Erase Intelligent Storage Drive appear only when a storage drive is installed. |

Home Screen Customization

Note: This menu appears only in the Embedded Web Server.

| Menu | Description |
|---|---|
| Copy E-mail Fax Held Faxes Release Held Faxes Status/Supplies Job Queue Settings Change Language Address Book Bookmarks Held Jobs USB Drive FTP Scan Profiles Lock Device Scan Center Card Copy Shortcut Center | Specify which icons to show on the home screen. |

Update firmware

| Menu item | Description |
|-------------------------------|--|
| Current Version | Show the current firmware version installed on the printer. |
| Check for updates now | Check for firmware updates. |
| Auto check for updates | Set the printer to check for firmware updates automatically. |

About this Printer

| Menu item | Description |
|---|---|
| Asset Tag | Specify the identity of the printer. The maximum length is 32 characters. |
| Printer's Location | Specify the printer location. The maximum length is 63 characters. |
| Contact | Specify the contact information for the printer. The maximum length is 63 characters. |
| Firmware Version | Show the firmware version installed on the printer. |
| Engine | Show the engine number of the printer. |
| Serial Number | Show the serial number of the printer. |
| Export Configuration File to USB | Export the configuration file to a flash drive. |
| Export Compressed Logs to USB | Export the compressed log files to a flash drive. |

Print

Layout

| Menu item | Description |
|---|---|
| Sides 1-Sided* 2-Sided | Specify whether to print on one side or both sides of the paper. |
| Flip Style Long Edge* Short Edge | Determine which side of the paper is bound when performing two-sided printing. |
| Blank Pages Print Do Not Print* | Print blank pages that are included in a print job. |
| Collate Off (1,1,1,2,2,2) On (1,2,1,2,1,2)* | Keep the pages of a print job stacked in sequence, particularly when printing multiple copies of the job. |
| Separator Sheets None* Between Copies Between Jobs Between Pages | Insert blank separator sheets when printing. |
| Separator Sheet Source Tray [x] (1*) Multipurpose Feeder | Specify the paper source for the separator sheet. |
| Note: An asterisk (*) next to a value indicates the factory default setting. | |

| Menu item | Description |
|---|---|
| Pages per Side Off* 2 pages per side 3 pages per side 4 pages per side 6 pages per side 9 pages per side 12 pages per side 16 pages per side | Print multiple page images on one side of a sheet of paper. |
| Pages per Side Ordering Horizontal* Reverse Horizontal Vertical Reverse Vertical | Specify the positioning of multiple page images when using the Pages per Side menu. |
| Pages per Side Orientation Auto* Landscape Portrait | Specify the orientation of multiple page images when using the Pages per Side menu. |
| Pages per Side Border None* Solid | Print a border around each page image when using the Pages per Side menu. |
| Copies 1–9999 (1*) | Specify the number of copies for each print job. |
| Print Area Normal* Whole Page | Set the printable area on a sheet of paper. |
| Note: An asterisk (*) next to a value indicates the factory default setting. | |

Setup

| Menu item | Description |
|---|--|
| Printer Language PCL Emulation* PS Emulation | Set the printer language. Note: Setting a printer language default does not prevent a software program from sending print jobs that use another printer language. |
| Job Waiting Off* On | Preserve print jobs requiring supplies so that jobs not requiring the missing supplies can print. Note: This menu item appears only when a hard disk or an intelligent storage drive (ISD) is installed. |
| Note: An asterisk (*) next to a value indicates the factory default setting. | |

| Menu item | Description |
|---|---|
| Job Hold Timeout 0–255 (30*) | Set the time in seconds that the printer waits for user intervention before it holds jobs that require unavailable resources. Note: This menu item appears only when a hard disk or an ISD is installed. |
| Download Target RAM* Disk | Specify where to save all permanent resources that have been downloaded to the printer. Note: This menu item appears only when a hard disk or an ISD is installed. |
| Resource Save Off* On | Determine what the printer does with downloaded resources when it receives a job that requires more than the available memory. Notes: <ul style="list-style-type: none"> When set to Off, the printer retains downloaded resources only until memory is needed. Resources associated with the inactive printer language are deleted. When set to On, the printer preserves all the permanent downloaded resources across all language switches. When necessary, the printer shows memory full messages instead of deleting permanent resources. |
| Print All Order Alphabetical* Newest First Oldest First | Specify the order when you choose to print all held and confidential jobs. |
| Note: An asterisk (*) next to a value indicates the factory default setting. | |

Quality

| Menu item | Description |
|--|--|
| Print Resolution 600 dpi 1200 Image Q* 2400 Image Q 1200 dpi 300 dpi | Set the resolution for the printed output. |
| Pixel Boost Off* Fonts* Horizontally Vertically Both directions | Enable more pixels to print in clusters for clarity, to enhance images horizontally or vertically or to enhance fonts. |
| Toner Darkness 1 to 10 (8*) | Determine the lightness or darkness of text images. |
| Note: An asterisk (*) next to a value indicates the factory default setting. | |

| Menu item | Description |
|---|--|
| Halftone Normal* Detail | Enhance the printed output to have smoother lines with sharper edges. |
| Brightness -6 to 6 (0*) | Adjust the printed output either by lightening or darkening it. |
| Contrast 0 to 5 (0*) | Adjust the contrast of printed objects. |
| Gray Correction Off Auto* | Enable the gray correction algorithm of the printer on printed images in mid-gray level. |
| Note: An asterisk (*) next to a value indicates the factory default setting. | |

Job Accounting

| Menu item | Description |
|--|--|
| Job Accounting Off* On | Set the printer to create a log of the print jobs that it receives. |
| Accounting Log Frequency Daily Weekly Monthly* | Specify how often the printer creates a log file. |
| Log Action at End of Frequency None* E-mail Current Log E-mail & Delete Current Log Post Current Log Post & Delete Current Log | Specify how the printer responds when the frequency threshold expires. Note: The value defined in Accounting Log Frequency determines when this action is triggered. |
| Log Near Full Level Off On* (5) | Specify the maximum size of the log file before the printer executes Log Action at Near Full. Note: This menu item appears only when a hard disk or an ISD is installed. |
| Note: An asterisk (*) next to a value indicates the factory default setting. | |

| Menu item | Description |
|---|---|
| Log Action at Near Full None* E-mail Current Log E-mail & Delete Current Log E-mail & Delete Oldest Log Post Current Log Post & Delete Current Log Post & Delete Oldest Log Delete Current Log Delete Oldest Log Delete All But Current Delete All Logs | Specify how the printer responds when the hard disk or ISD is nearly full. Note: The value defined in Log Near Full Level determines when this action is triggered. |
| Log Action at Full None* E-mail & Delete Current Log E-mail & Delete Oldest Log Post & Delete Current Log Post & Delete Oldest Log Delete Current Log Delete Oldest Log Delete All But Current Delete All Logs | Specify how the printer responds when hard disk or ISD usage reaches the maximum limit (100MB). |
| URL to Post Log | Specify where the printer posts job accounting logs. |
| E-mail Address to Send Logs | Specify the email address to which the printer sends job accounting logs. |
| Log File Prefix | Specify the prefix for the log files. Note: The current host name defined in the TCP/IP menu is used as the default log file prefix. |
| Note: An asterisk (*) next to a value indicates the factory default setting. | |

PDF

| Menu item | Description |
|---|--|
| Scale To Fit Off* On | Scale the page content to fit the selected paper size. |
| Annotations Print Do Not Print* | Specify whether to print annotations in the PDF. |
| Print PDF Error Off On* | Enable the printing of PDF error. |
| Note: An asterisk (*) next to a value indicates the factory default setting. | |

PostScript

| Menu item | Description |
|---|--|
| Print PS Error Off* On | Print a page that describes the PostScript® error. Note: When an error occurs, processing of the job stops, the printer prints an error message, and the rest of the print job is flushed. |
| Minimum Line Width 1–30 (2*) | Set the minimum stroke width. Note: Jobs printed in 1200 dpi use the value directly. |
| Lock PS Startup Mode Off On* | Disable the SysStart file. Note: Enabling the SysStart file exposes your printer or network to a security risk. |
| Font Priority Resident* Flash/Disk | Establish the font search order. Notes: <ul style="list-style-type: none"> Resident sets the printer to search its memory for the requested font before searching the hard disk or intelligent storage drive (ISD). Flash/Disk sets the printer to search the hard disk or ISD for the requested font before searching the printer memory. This menu item appears only when a hard disk or an ISD is installed. |
| Wait Timeout Off On* (40 seconds) | Enable the printer to wait for more data before canceling a print job. |
| Note: An asterisk (*) next to a value indicates the factory default setting. | |

PCL

| Menu item | Description |
|---|---|
| Font Source Resident* Disk Download Flash Font Card All | Select the source which contains the default font selection. Notes: <ul style="list-style-type: none"> Disk and Flash appear only when a hard disk or an intelligent storage drive (ISD) that contains fonts is installed. Download appears only if downloaded fonts exist in the printer memory. Font Card appears only when an ISD is installed. |
| Font Name [List of available fonts] (Courier*) | Select a font from the specified font source. |
| Symbol Set [List of available symbol set] (10U PC-8*) | Specify the symbol set for each font name. Note: A symbol set is a set of alphabetic and numeric characters, punctuation, and special symbols. Symbol sets support the different languages or specific programs such as math symbols for scientific text. |
| Note: An asterisk (*) next to a value indicates the factory default setting. | |

| Menu item | Description |
|--|---|
| Pitch 0.08–100.00 (10.00*) | Specify the pitch for fixed or monospaced fonts. Note: Pitch refers to the number of fixed-space characters in a horizontal inch of type. |
| Orientation Portrait* Landscape Reverse Portrait Reverse Landscape | Specify the orientation of text and graphics on the page. |
| Lines per Page 1–255 | Specify the number of lines of text for each page printed through the PCL® data stream. Notes: <ul style="list-style-type: none"> This menu item activates vertical escapement that causes the selected number of requested lines to print between the default margins of the page. 60 is the U.S. factory default setting. 64 is the international factory default setting. |
| PCL5 Minimum Line Width 1–30 (2*) | Set the initial minimum stroke width. |
| PCLXL Minimum Line Width 1–30 (2*) | |
| A4 Width 198 mm* 203 mm | Set the width of the logical page on A4-size paper. Note: Logical page is the space on the physical page where data is printed. |
| Auto CR after LF On Off* | Set the printer to perform a carriage return after a line feed control command. Note: Carriage return is a mechanism that commands the printer to move the position of the cursor to the first position on the same line. |
| Auto LF after CR On Off* | Set the printer to perform a line feed after a carriage return control command. |
| Tray Renumber Assign MP Feeder Assign Tray [x] Assign Manual Paper Assign Manual Envelope | Configure the printer to work with a different print driver or custom application that uses a different set of source assignments to request a given paper source. Choose from the following options: Off*—The printer uses the factory default paper source assignments. None—The paper source ignores the Select Paper Feed command. 0–199—Select a numeric value to assign a custom value to a paper source. |
| Tray Renumber View Factory Defaults | Show the factory default value assigned for each paper source. |
| Note: An asterisk (*) next to a value indicates the factory default setting. | |

| Menu item | Description |
|---|--|
| Tray Renumber Restore Defaults | Restore the tray renumber values to their factory defaults. |
| Print Timeout Off On* (90 seconds) | Set the printer to end a print job after it has been idle for the specified amount of time. Note: Print Timeout Time appears only when Print Timeout is enabled. |
| Note: An asterisk (*) next to a value indicates the factory default setting. | |

Image

| Menu item | Description |
|--|---|
| Auto Fit On Off* | Select the best available paper size and orientation setting for an image. Note: When set to On, this menu item overrides the scaling and orientation settings for the image. |
| Invert Off* On | Invert bitonal monochrome images. Note: This menu item does not apply to GIF or JPEG image formats. |
| Scaling Anchor Top Left Best Fit* Anchor Center Fit Height/Width Fit Height Fit Width | Adjust the image to fit the printable area. Note: When Auto Fit is set to On, Scaling is automatically set to Best Fit. |
| Orientation Portrait* Landscape Reverse Portrait Reverse Landscape | Specify the orientation of text and graphics on the page. |
| Note: An asterisk (*) next to a value indicates the factory default setting. | |

Paper

Tray Configuration

| Menu item | Description |
|--|---|
| Default Source Tray [x] (1*) Multipurpose Feeder Manual Paper Manual Envelope | Set the paper source for all print jobs. |
| Paper Size/Type Tray [x] Multipurpose Feeder Manual Paper Manual Envelope | Specify the paper size or paper type loaded in each paper source. |
| Substitute Size Off Letter/A4 All Listed* | Set the printer to substitute a specified paper size if the requested size is not loaded in any paper source. Notes: <ul style="list-style-type: none"> • Off prompts the user to load the required paper size. • All Listed allows all available substitutions. |
| Configure MP Cassette* Manual First | Determine the behavior of the multipurpose feeder. Notes: <ul style="list-style-type: none"> • Cassette configures the multipurpose feeder as the automatic paper source. • Manual sets the multipurpose feeder only for manual-feed print jobs. • First configures the multipurpose feeder as the primary paper source. |
| Note: An asterisk (*) next to a value indicates the factory default setting. | |

Media Configuration

Universal Setup

| Menu item | Description |
|---|--|
| Units of Measure Inches Millimeters | Specify the unit of measurement for the universal paper. Note: Inches is the U.S. factory default setting. Millimeters is the international factory default setting. |
| Portrait Width 3.5–19 inches (8.5*) 88.9–482.6 mm (216*) | Set the portrait width of the universal paper. |
| Note: An asterisk (*) next to a value indicates the factory default setting. | |

| Menu item | Description |
|---|--|
| Portrait Height 3.5–19 inches (14*) 88.9–482.6 mm (356*) | Set the portrait height of the universal paper. |
| Feed Direction Short Edge* Long Edge | Set the printer to pick paper from the short edge or long edge direction. Note: Long Edge appears only when the longest edge is shorter than the maximum width supported. |
| Multiple Universal Sizes Tray [x] Multipurpose Feeder | Assign a unique dimension for multiple universal sizes that are loaded in each paper source. Note: This setting appears only when enabled in the Device menu. From the home screen, touch Settings > Device > Maintenance > Configuration Menu > Tray Configuration > Multiple Universal Sizes . |
| Note: An asterisk (*) next to a value indicates the factory default setting. | |

Custom Scan Sizes

| Menu item | Description |
|---|--|
| Custom Scan Size [x] Scan Size Name Width 1–8.5 inches (8.5*) 25.4–215.9 mm (215.9*) Height 1–25 inches (11*) 25.4–635 mm (279.4*) Orientation Portrait* Landscape 2 scans per side Off* On | Assign a scan size name and configure the scan settings. |

Media Types

| Menu item | Description |
|---|--|
| Plain Paper Card Stock Recycled Labels Bond Envelope Rough Envelope Letterhead Preprinted Colored Paper Light Paper Heavy Paper Rough/Cotton Custom Type [X] | Specify the texture, weight, and orientation of the paper. |

Copy

Copy Defaults

| Menu item | Description |
|---|--|
| Content Type Text Text/Photo* Photo Graphics | Improve the output result based on the content of the original document. |
| Content Source Black and White Laser* Color Laser Inkjet Photo/Film Magazine Newspaper Press Other | Improve the output result based on the source of the original document. |
| Sides 1 sided to 1 sided* 1 sided to 2 sided 2 sided to 1 sided 2 sided to 2 sided | Specify the scanning behavior based on the original document. |
| Note: An asterisk (*) next to a value indicates the factory default setting. | |

| Menu item | Description |
|---|---|
| Separator Sheets None* Between Copies Between Jobs Between Pages | Specify whether to insert blank separator sheets when printing. |
| Separator Sheet Source Tray [x] (1*) Multipurpose Feeder | Specify the paper source for the separator sheet. |
| Color Off On* Auto | Set the printer to generate color output from a scan job. |
| Pages per Side Off* 2 Portrait pages 4 Portrait pages 2 Landscape pages 4 Landscape pages | Specify the number of page images to print on one side of a sheet of paper. |
| Print Page Borders Off* On | Place a border around each image when printing multiple pages on a single page. |
| Collate Off [1,1,1,2,2,2] On [1,2,1,2,1,2]* | Print multiple copies in sequence. |
| “Copy from” Size [List of paper sizes] | Set the paper size of the original document. Note: Letter is the U.S. factory default setting. A4 is the international factory default setting. |
| “Copy to” Source Tray [x] (1*) Multipurpose Feeder Auto Size Match | Specify the paper source for the copy job. |
| Temperature -4 to 4 (0*) | Specify whether to generate a cooler or warmer output. |
| Darkness 1 to 9 (5*) | Adjust the darkness of the scanned image. |
| Number of Copies 1–9999 (1*) | Specify the number of copies. |
| Note: An asterisk (*) next to a value indicates the factory default setting. | |

| Menu item | Description |
|--|--|
| Header/Footer Left Header Middle Header Right Header Left Footer Middle Footer Right Footer | Specify the header or footer information on the scanned image. |
| Overlay Confidential Copy Draft Urgent Custom Off* | Specify the overlay text to print on each copy. |
| Custom overlay | Type the text for the Custom choice in the Overlay menu. |
| Note: An asterisk (*) next to a value indicates the factory default setting. | |

Advanced Imaging

| Menu item | Description |
|---|--|
| Color Balance Cyan - Red (0*) Magenta - Green (0*) Yellow - Blue (0*) | Adjust the color intensity for cyan, magenta, and yellow. |
| Color Dropout Color Dropout (None*) Default Red Threshold (128*) Default Green Threshold (128*) Default Blue Threshold(128*) | Specify which color to drop during scanning, and adjust the dropout setting for that color. |
| Auto Color Detect Color Sensitivity (5*) Area Sensitivity (5*) | Configure the auto color detection setting. |
| Contrast Best for content* 0–5 | Specify the contrast for the scanned image. |
| Background Removal Background Detection (Content-based*) Level (0*) | Remove the background color or image noise from the original document. Notes: <ul style="list-style-type: none"> • Content-based removes the background color from the original document . • Fixed removes image noise from a photo. |
| Note: An asterisk (*) next to a value indicates the factory default setting. | |

| Menu item | Description |
|---|--|
| Auto Center Off* On | Align the content at the center of the page. |
| Mirror Image Off* On | Create a mirror image of the original document. |
| Negative Image Off* On | Create a negative image of the original document. |
| Shadow Detail -4 to 4 (0*) | Adjust the shadow detail in the original document. |
| Scan Edge to Edge Off* On | Scan the original document from edge to edge. |
| Sharpness 1–5 (3*) | Adjust the sharpness of the scanned image. |
| Note: An asterisk (*) next to a value indicates the factory default setting. | |

Admin Controls

| Menu item | Description |
|---|--|
| Allow Color Copies Off On* | Print copies in color. |
| Allow Priority Copies Off On* | Interrupt a print job to make copies. |
| Custom Job Scanning Off* On | Set the printer to scan the first set of original documents using the specified settings, and then scan the next set with the same or different settings. Note: This menu item appears only when a hard disk or an intelligent storage drive (ISD) is installed. |
| Allow Save as Shortcut Off On* | Save copy settings as a shortcut. |
| Adjust ADF Skew Off On* | Set the printer to adjust the skewed images from documents that are scanned from the ADF. |
| Sample copy Off* On | Print a sample copy to check the quality before printing the remaining copies. Note: This menu item appears only when a hard disk or an ISD is installed. |
| Note: An asterisk (*) next to a value indicates the factory default setting. | |

Fax

Fax Defaults

Fax Mode

| Menu item | Description |
|---|--------------------|
| Fax Mode Fax* Fax Server Disabled | Select a fax mode. |

Fax Setup

General Fax Settings

| Menu item | Description |
|---|--|
| Fax Name | Specify your fax ID. |
| Fax Number | Specify your fax number. |
| Fax ID Fax Name Fax Number* | Set the fax ID to use during fax negotiation. |
| Enable Manual Fax Off* On | Turn on the manual fax function in the printer. Notes: <ul style="list-style-type: none"> This menu item requires a line splitter and a telephone handset. Use a regular telephone line to answer an incoming fax job and to dial a fax number. To go directly to the manual fax function, touch # and 0 on the keypad. |
| Memory Use All receive Mostly receive Equal* Mostly send All send | Set the amount of internal printer memory allocated for faxing. Note: This menu item prevents memory buffer conditions and failed faxes. |
| Cancel Faxes Allow* Don't Allow | Cancel outgoing or incoming faxes. |
| Note: An asterisk (*) next to a value indicates the factory default setting. | |

| Menu item | Description |
|---|--|
| Fax Number Masking Off* From Left From Right | Specify the format for masking an outgoing fax number. |
| Digits to Mask 0–58 (0*) | Specify the number of digits to mask in an outgoing fax number. |
| Enable Line Connected Detection Off On* | Determine whether a telephone line is connected to the printer. Note: Events are detected immediately. |
| Enable Line In Wrong Jack Detection Off On* | Determine whether a telephone line is connected to the correct port on the printer. Note: Events are detected immediately. |
| Enable Extension in Use Support Off On* | Determine whether a telephone line is used by another device, such as another phone on the same line. Note: Events are detected immediately. |
| Optimize Fax Compatibility | Configure the printer fax functionality for optimal compatibility with other fax machines. |
| Fax Transport T.38 Analog G.711 | Set the fax transport method. Note: This menu item appears only if Fax over IP (FoIP) license bundle is installed in the printer. |
| Note: An asterisk (*) next to a value indicates the factory default setting. | |

Fax Send Settings

| Menu item | Description |
|---|--|
| Resolution Standard* Fine Super Fine Ultra Fine | Set the resolution of the scanned image. Note: A higher resolution increases fax transmission time and requires more memory. |
| Original Size [List of paper sizes] (Mixed Sizes*) | Specify the size of the original document. |
| Orientation Portrait* Landscape | Specify the orientation of the original document. |
| Sides Off* Short Edge Long Edge | Specify the orientation of the original document when scanning on both sides of the document. |
| Note: An asterisk (*) next to a value indicates the factory default setting. | |

| Menu item | Description |
|---|---|
| Content Type Text* Text/Photo Photo Graphics | Improve the output result based on the content of the original document. |
| Content Source Black and White Laser* Color Laser Inkjet Photo/Film Magazine Newspaper Press Other | Improve the output result based on the source of the original document. |
| Darkness 1–9 (5*) | Adjust the darkness of the scanned image. |
| Behind a PABX On Off* | Set the printer to dial a fax number without waiting to recognize the dial tone. Note: Private Automated Branch Exchange (PABX) is a telephone network that allows a single access number to offer multiple lines to outside callers. |
| Dial Mode Tone* Pulse | Specify the dial mode for incoming or outgoing faxes. |
| Note: An asterisk (*) next to a value indicates the factory default setting. | |

Advanced Imaging

| Menu item | Description |
|--|---|
| Color Balance Cyan - Red (0*) Magenta - Green (0*) Yellow - Blue (0*) | Adjust the color intensity during scanning. |
| Color Dropout Color Dropout (None*) Default Red Threshold (128*) Default Green Threshold (128*) Default Blue Threshold (128*) | Specify which color to drop during scanning, and adjust the dropout setting for that color. |
| Note: An asterisk (*) next to a value indicates the factory default setting. | |

| Menu item | Description |
|---|--|
| Contrast Best for Content* 0 1 2 3 4 5 | Set the contrast of the output. |
| Background Removal Level -4 to 4 (0*) | Adjust the amount of background visible on a scanned image. |
| Mirror Image Off* On | Create a mirror image of the original document. |
| Negative Image Off* On | Create a negative image of the original document. |
| Shadow Detail -4 to 4 (0*) | Adjust the amount of shadow detail visible on a scanned image. |
| Scan Edge to Edge On Off* | Allow edge-to-edge scanning of the original document. |
| Sharpness 1–5 (3*) | Adjust the sharpness of the scanned image. |
| Temperature -4 to 4 (0*) | Specify whether to generate a cooler or warmer output. |
| Note: An asterisk (*) next to a value indicates the factory default setting. | |

Admin Controls

| Menu item | Description |
|---|---|
| Automatic Redial 0–9 (5*) | Specify the number of attempts that the printer redials before it cancels sending the fax to a specified destination. |
| Redial Frequency 1–200 minutes (3*) | Increase the time between redial attempts to increase the chance of sending fax successfully. |
| Enable ECM On* Off | Activate Error Correction Mode (ECM) for fax jobs. Note: ECM detects and corrects errors in the fax transmission process caused by telephone line noise and poor signal strength. |
| Note: An asterisk (*) next to a value indicates the factory default setting. | |

| Menu item | Description |
|--|--|
| Enable Fax Scans On* Off | Create faxes using the printer scanner. |
| Driver to Fax On* Off | Allow the print driver to send fax. |
| Allow Save as Shortcut On* Off | Save fax numbers as shortcuts on the printer. |
| Max Speed 33600* 14400 9600 4800 2400 | Set the maximum speed for sending fax. |
| Custom Job Scanning Off* On | Turn on scanning of custom jobs by default. Note: This menu item appears only when a hard disk or an intelligent storage drive (ISD) is installed. |
| Scan Preview Off* On | Show a preview of the scan on the display. Note: This menu item appears only when a hard disk or an ISD is installed. |
| Adjust ADF Skew Off On* | Correct slight skew in the scanned image. |
| Enable Color Fax Scans Off by Default* On by Default Never Use Always Use | Enable color scans for fax. |
| Auto Convert Color Faxes to Mono Faxes On* Off | Convert all outgoing color faxes to black and white. |
| Confirm Fax Number Off* On | Ask the user to confirm the fax number. |
| Dial Prefix | Set a dialing prefix. |
| Dialing Prefix Rules | Establish a dialing prefix rule. |
| Note: An asterisk (*) next to a value indicates the factory default setting. | |

Fax Receive Settings

| Menu item | Description |
|---|--|
| Fax Job Waiting None* Toner Toner and Supplies | Remove fax jobs that request specific unavailable resources from the print queue. Note: This menu item appears only when a hard disk is installed. |
| Rings to Answer 1–25 (3*) | Set the number of rings required before the printer answers the incoming calls. |
| Auto Reduction On* Off | Scale incoming fax to fit on the page. |
| Paper Source Tray [X] Multipurpose Feeder Auto* | Set the paper source for printing incoming fax. |
| Sides On Off* | Print on both sides of the paper. |
| Separator Sheets None* Before Job After Job | Specify whether to insert blank separator sheets when printing. |
| Separator Sheet Source Tray [X] (1*) Multipurpose Feeder | Specify the paper source for the separator sheet. |
| Output Bin Standard Bin | Specify the output bin for received faxes. |
| Fax Footer On Off* | Print the transmission information at the bottom of each page from a received fax. |
| Fax Footer Time Stamp Receive* Print | Print the time stamp at the bottom of each page from a received fax. |
| Holding Faxes Held Fax Mode Off* Always On Manual Scheduled | Hold received faxes from printing until they are released. |

Note: An asterisk (*) next to a value indicates the factory default setting.

| Menu item | Description |
|---|--|
| Holding Faxes Fax Holding Schedule | Assign a schedule for holding faxes. Note: This menu item appears only if Held Fax Mode is set to Scheduled. |
| Note: An asterisk (*) next to a value indicates the factory default setting. | |

Admin Controls

| Menu item | Description |
|---|--|
| Enable Fax Receive On* Off | Set the printer to receive fax. |
| Enable Color Fax Receive On* Off | Set the printer to receive fax in color. |
| Enable Caller ID On Off* | Show the caller ID information of the incoming call on the printer display. |
| Block No Name Fax On Off* | Block incoming faxes without fax IDs. |
| Banned Fax List Add Banned Fax | Specify the phone numbers that you want to block. |
| Answer On All Rings* Single Ring Only Double Ring Only Triple Ring Only Single or Double Rings Only Single or Triple Rings Only Double or Triple Rings Only | Set a distinctive ring pattern for incoming fax. |
| Auto Answer On* Off | Set the printer to receive fax automatically. |
| Manual Answer Code 0–9 (9*) | Manually enter a code on the telephone number pad to begin receiving fax. Notes: <ul style="list-style-type: none"> This menu item appears only when the printer shares a line with a telephone. This menu item appears only when you set the printer to receive fax manually. |
| Note: An asterisk (*) next to a value indicates the factory default setting. | |

| Menu item | Description |
|---|---|
| Fax Forwarding Print* Print and Forward Forward | Specify whether to forward received fax. |
| Forward To Destination 1 Destination 2 | Specify where to forward received fax. Note: This menu item appears only when Fax Forwarding is set to Print and Forward or Forward. |
| Confirmation E-mail | Specify the email address to receive faxes through FTP or network folder. Note: This menu item appears only when Fax Forwarding is set to Print and Forward or Forward. |
| Max Speed 33600* 14400 9600 4800 2400 | Set the maximum speed for transmitting fax. |
| Note: An asterisk (*) next to a value indicates the factory default setting. | |

Fax Cover Page

| Menu item | Description |
|--|--|
| Fax Cover Page Off by Default* On by Default Never Use Always Use | Configure the settings for the fax cover page. |
| Include To field Off* On | |
| Include From field Off* On | |
| From | |
| Include Message Field Off* On | |
| Message: | |
| Include Logo Off* On | |
| Include Footer [x] Off* On | |
| Footer [x] | |
| Note: An asterisk (*) next to a value indicates the factory default setting. | |

Fax Log Settings

| Menu item | Description |
|---|---|
| Transmission Log Frequency Always* Never Only for Error | Specify how often the printer creates a transmission log. |
| Transmission Log Action Print Off On* E-mail Off* On | |
| Note: An asterisk (*) next to a value indicates the factory default setting. | |

| Menu item | Description |
|---|---|
| Receive Error Log Print Never* Print on Error | Print a log for fax-receive failures. |
| Auto Print Logs On* Off | Print all fax activity. |
| Log Paper Source Tray [x] (1*) Multipurpose Feeder | Specify the paper source for printing logs. |
| Logs Display Remote Fax Name* Dialed Number | Identify the sender by remote fax name or fax number. |
| Enable Job Log On* Off | View a summary of all fax jobs. |
| Enable Call Log On* Off | View a summary of the fax call history. |
| Log Output Bin Standard Bin* Bin [x] | Specify the output bin for printed logs. |
| Note: An asterisk (*) next to a value indicates the factory default setting. | |

Speaker Settings

| Menu item | Description |
|---|--------------------------------|
| Speaker Mode Always Off* Always On On until Connected | Set the fax speaker mode. |
| Speaker Volume Low* High | Adjust the fax speaker volume. |
| Ringer Volume Off* On | Enable the ringer volume. |
| Note: An asterisk (*) next to a value indicates the factory default setting. | |

VoIP Settings

| Menu item | Description |
|---|--|
| VoIP Protocol SIP* H.323 | Set the Voice over Internet Protocol (VoIP) protocol. |
| STUN Server | Specify the STUN server to traverse a firewall. |
| Force Fax Mode Off On* | Switch VoIP gateway from analog to T.38 at the beginning of a fax call. |
| Force Fax Mode Delay 0–15 (7*) | Set the time delay in seconds when sending another invite of Force Fax Mode. |
| Note: An asterisk (*) next to a value indicates the factory default setting. | |

SIP Settings

| Menu item | Description |
|---|---|
| Proxy | Specify the IP address of the system that converts the phone number to an IP address where the fax is sent. |
| Registrar | Specify a name or IP address of the system that handles the registration of Session Initiation Protocol (SIP) clients. |
| User | Specify the name of the user for SIP. |
| Password | Specify the password that is used in registering with the SIP Registrar. |
| Auth ID | The username that is used when registering. Note: If the Auth ID setting is not set, the setting uses the username of the User field instead. |
| Transport For Registration UDP* TCP | Set the SIP transport type for registration. |
| Transport For Incoming Calls UDP* TCP UDP And TCP | Set the SIP transport type for incoming calls. |
| Transport For Outgoing Calls UDP* TCP | Set the SIP transport type for outgoing calls. |
| Outbound Proxy | Specify an outbound proxy to forward all SIP communication. |
| Contact | Specify a contact name for SIP. |
| Note: An asterisk (*) next to a value indicates the factory default setting. | |

| Menu item | Description |
|---|--|
| Realm | Specify a realm name for SIP. Note: If the Realm setting is not set, the setting uses the name of the Contact instead. |
| SIP Registration Status | Show the status of the SIP Registration. |
| Note: An asterisk (*) next to a value indicates the factory default setting. | |

H.323 Settings

| Menu item | Description |
|---|---|
| Gateway | Specify the H.323 gateway IP address. |
| Gatekeeper | Specify the H.323 gatekeeper. |
| User | Specify the username used with the H.323 gateway. |
| Password | Specify the password for the H.323 gateway. |
| Enable Fast Start Off* On | Enable Fast Start. |
| Disable H.245 Tunneling Off* On | Disable H.323 Tunneling. |
| Disable Gatekeeper Discovery Off On* | Disable H.323 Gatekeeper Discovery. |
| Note: An asterisk (*) next to a value indicates the factory default setting. | |

T.38 Settings

| Menu item | Description |
|---|---|
| Indicator Redundancy 0–5 (3*) | Set the number of times that a fax indicator is repeated in the T.38 communication. |
| Low Speed Redundancy 0–5 (3*) | Set the number of times that low speed data is repeated in the T.38 communication. |
| High Speed Redundancy 0–5 (1*) | Set the number of times that high-speed data is repeated in the T.38 communication. |
| Note: An asterisk (*) next to a value indicates the factory default setting. | |

Fax Server Setup

General Fax Settings

| Menu item | Description |
|---|--|
| To Format | Specify a fax recipient. Note: If you want to use the fax number, then type the number sign (#) before a number. |
| Reply Address | Specify a reply address for sending fax. |
| Subject | Specify the fax subject and message. |
| Message | |
| Enable analog receive Off* On | Set the printer to receive analog faxes. |
| Note: An asterisk (*) next to a value indicates the factory default setting. | |

Fax Server E-mail Settings

| Menu item | Description |
|---|--|
| Use E-mail SMTP Server On Off* | Use the Simple Mail Transfer Protocol (SMTP) settings for email in receiving and sending faxes. Note: When set to On, all other settings of the Fax Server E-mail Settings menu are not shown. |
| Primary SMTP Gateway | Type the IP address or host name of the primary SMTP server. |
| Primary SMTP Gateway Port 1–65535 (25*) | Enter the port number of the primary SMTP server. |
| Secondary SMTP Gateway | Type the server IP address or host name of your secondary or backup SMTP server. |
| Secondary SMTP Gateway Port 1–65535 (25*) | Enter the server port number of your secondary or backup SMTP server. |
| SMTP Timeout 5–30 (30*) | Set the time before the printer times out if the SMTP server does not respond. |
| Reply Address | Specify a reply address for sending fax. |
| Use SSL/TLS Disabled* Negotiate Required | Specify whether to send fax using an encrypted link. |
| Require Trusted Certificate Off On* | Specify a trusted certificate when accessing the SMTP server. |
| Note: An asterisk (*) next to a value indicates the factory default setting. | |

| Menu item | Description |
|--|---|
| SMTP Server Authentication No authentication required* Login / Plain NTLM CRAM-MD5 Digest-MD5 Kerberos 5 | Set the authentication type for the SMTP server. |
| Device-Initiated E-mail None* Use Device SMTP Credentials | Specify whether credentials are required for device-initiated email. |
| User-Initiated E-mail None* Use Device SMTP Credentials Use Session User ID and Password Use Session E-mail address and Password Prompt user | Specify whether credentials are required for user-initiated email. |
| Use Active Directory Device Credentials Off* On | Enable user credentials and group destinations to connect to the SMTP server. |
| Device Userid | Specify the user ID and password to connect to the SMTP server. |
| Device Password | |
| Kerberos 5 REALM | Specify the realm for the Kerberos 5 authentication protocol. |
| NTLM Domain | Specify the domain name for the NTLM security protocol. |
| Disable "SMTP server not set up" error Off* On | Hide the "SMTP server not set up" error message. |
| Note: An asterisk (*) next to a value indicates the factory default setting. | |

Fax Server Scan Settings

| Menu item | Description |
|---|--|
| Image Format TIFF (.tif) PDF (.pdf)* XPS (.xps) TXT (.txt) RTF (.rtf) DOCX (.docx) XLSX (.xlsx) CSV (.csv) | Specify the file format for the scanned image. Note: TXT (.txt), RTF (.rtf), DOCX (.docx), XLSX (.xlsx), and CSV (.csv) appear only if you have purchased and installed an OCR solution. |
| Content Type Text* Text/Photo Photo Graphics | Improve the output result based on the content of the original document. |
| Content Source Black and White Laser* Color Laser Inkjet Photo/Film Magazine Newspaper Press Other | Improve the output result based on the source of the original document. |
| Fax Resolution Standard* Fine Super Fine Ultra Fine | Set the fax resolution. |
| Sides Off* Short Edge Long Edge | Specify the orientation of the original document when scanning on both sides of the document. |
| Darkness 1–9 (5*) | Set the darkness of the output. |
| Orientation Portrait* Landscape | Specify the orientation of text and graphics on the page. |
| Note: An asterisk (*) next to a value indicates the factory default setting. | |

| Menu item | Description |
|---|---|
| Original Size [List of paper sizes] | Set the paper size of the original document. Notes: <ul style="list-style-type: none"> • Mixed Sizes is the U.S. factory default setting. A4 is the international factory default setting. • This setting may vary depending on your printer model. |
| Use Multi-Page TIFF Off On* | Choose between single- and multiple-page TIFF files. |
| Note: An asterisk (*) next to a value indicates the factory default setting. | |

E-mail

E-mail Setup

| Menu item | Description |
|---|--|
| Primary SMTP Gateway | Type the IP address or host name of the primary SMTP server for sending e-mail. |
| Primary SMTP Gateway Port 1–65535 (25*) | Enter the port number of the primary SMTP server. |
| Secondary SMTP Gateway | Type the server IP address or host name of your secondary or backup SMTP server. |
| Secondary SMTP Gateway Port 1–65535 (25*) | Enter the server port number of your secondary or backup SMTP server. |
| SMTP Timeout 5–30 seconds (30*) | Set the time before the printer times out if the SMTP server does not respond. |
| Reply Address | Specify a reply address in the e-mail. |
| Always use SMTP default Reply Address On Off* | Always use the default reply address in the SMTP server. |
| Use SSL/TLS Disabled* Negotiate Required | Specify whether to send e-mail using an encrypted link. |
| Require Trusted Certificate Off On* | Require a trusted certificate when accessing the SMTP server. |
| Note: An asterisk (*) next to a value indicates the factory default setting. | |

| Menu item | Description |
|--|---|
| SMTP Server Authentication No authentication required* Login / Plain NTLM CRAM-MD5 Digest-MD5 Kerberos 5 | Set the authentication type for the SMTP server. |
| Device-Initiated E-mail None* Use Device SMTP Credentials | Specify whether credentials are required for device-initiated e-mail. |
| User-Initiated E-mail None* Use Device SMTP Credentials Use Session User ID and Password Use Session E-mail address and Password Prompt user | Specify whether credentials are required for user-initiated e-mail. |
| Use Active Directory Device Credentials Off* On | Specify whether credentials are required for user-initiated e-mail. |
| Device Userid | Specify the user ID and password to connect to the SMTP server. |
| Device Password | |
| Kerberos 5 REALM | Specify the realm for the Kerberos 5 authentication protocol. |
| NTLM Domain | Specify the domain name for the NTLM security protocol. |
| Disable "SMTP server not set up" error Off* On | Hide the "SMTP server not set up" error message. |
| Note: An asterisk (*) next to a value indicates the factory default setting. | |

E-mail Defaults

| Menu item | Description |
|---|--|
| Subject: | Specify the e-mail subject and message. |
| Message: | |
| File Name | Specify the filename for the scanned document. |
| Note: An asterisk (*) next to a value indicates the factory default setting. | |

| Menu item | Description |
|--|--|
| Format JPEG (.jpg) PDF (.pdf)* TIFF (.tif) XPS (.xps) TXT (.txt) RTF (.rtf) DOCX (.docx) XLSX (.xlsx) CSV (.csv) | Specify the file format of the scanned document. Note: TXT (.txt), RTF (.rtf), DOCX (.docx), XLSX (.xlsx), and CSV (.csv) appear only if you have purchased and installed an OCR solution. |
| Global OCR Settings Recognized Languages Auto Rotate (Off*) Despeckle (Off*) Auto Contrast Enhance (Off*) | Configure the settings for optical character recognition (OCR). Note: This menu item appears only if you have purchased and installed an OCR solution. |
| PDF Settings PDF Version (1.5*) Archival Version (A-1a*) Highly Compressed (Off*) Secure (Off*) Searchable (Off*) Archival (PDF/A) (Off*) | Configure the PDF settings of the scanned document. Notes: <ul style="list-style-type: none"> • Archival Version and Archival (PDF/A) are supported only when PDF Version is set to 1.4. • Highly Compressed appears only when a hard disk or an intelligent storage drive (ISD) is installed. • Searchable appears only if you have purchased and installed an OCR solution. |
| Content Type Text Text/Photo* Photo Graphics | Improve the output result based on the content type of the original document. |
| Content Source Black and White Laser* Color Laser Inkjet Photo/Film Magazine Newspaper Press Other | Improve the output result based on the content source of the original document. |
| Color Black and White Gray Color* Auto | Set the printer to capture file content in color or in mono. |
| Note: An asterisk (*) next to a value indicates the factory default setting. | |

| Menu item | Description |
|---|---|
| Resolution 75 dpi 150 dpi* 200 dpi 300 dpi 400 dpi 600 dpi | Set the resolution of the scanned image. |
| Darkness 1–9 (5*) | Adjust the darkness of the scanned image. |
| Orientation Portrait* Landscape | Specify the orientation of the original document. |
| Original Size Mixed Sizes* | Set the paper size of the original document. |
| Sides Off* Short Edge Long Edge | Specify the orientation of the original document when scanning on both sides of the document. |
| Note: An asterisk (*) next to a value indicates the factory default setting. | |

Advanced Imaging

| Menu item | Description |
|--|---|
| Color Balance Cyan - Red (0*) Magenta - Green (0*) Yellow - Blue (0*) | Adjust the color intensity for cyan, magenta, and yellow. |
| Color Dropout Color Dropout (None*) Default Red Threshold (128*) Default Green Threshold (128*) Default Blue Threshold (128*) | Specify which color to drop during scanning, and adjust the dropout setting for that color. |
| Auto Color Detect Color Sensitivity (5*) Area Sensitivity (5*) E-mail Bit Depth (1 bit*) Minimum Scan Resolution (300 dpi*) | Configure the auto color detection setting. |
| JPEG Quality Best for content* 5–95 | Set the JPEG quality of the scanned image. |
| Note: An asterisk (*) next to a value indicates the factory default setting. | |

| Menu item | Description |
|--|---|
| Contrast Best for content* 0–5 | Specify the contrast for the scanned image. |
| Background Removal Background Detection (Content-based*) Level (0*) | Remove the background color or image noise from the original document. Notes: <ul style="list-style-type: none"> • Content-based removes the background color from the original document. • Fixed removes image noise from a photo. |
| Mirror Image Off* On | Create a mirror image of the original document. |
| Negative Image Off* On | Create a negative image of the original document. |
| Shadow Detail -4 to 4 (0*) | Adjust the shadow detail in the scanned image. |
| Scan Edge to Edge Off* On | Scan the original document from edge to edge. |
| Sharpness 1–5 (3*) | Adjust the sharpness in the scanned image. |
| Temperature -4 to 4 (0*) | Generate a bluer or redder output of the original document. |
| Blank Pages Blank Page Removal (Do Not Remove*) Blank Page Sensitivity (5*) | Set the sensitivity of scans in relation to blank pages in the original document. |
| Note: An asterisk (*) next to a value indicates the factory default setting. | |

Admin Controls

| Menu item | Description |
|---|---|
| Max E-mail Size 0–65535 (0*) | Set the allowable file size for each e-mail. |
| Size Error Message | Specify an error message that the printer sends when an e-mail exceeds its allowable file size. Note: You can type up to 1024 characters. |
| Limit Destinations | Limit sending of e-mail only to the specified list of domain name. Note: Use a comma to separate each domain. |
| Note: An asterisk (*) next to a value indicates the factory default setting. | |

| Menu item | Description |
|---|--|
| Send Me a Copy Never appears* On by Default Off by Default Always On | Send a copy of the e-mail to yourself. |
| Allow self e-mails only Off* On | Set the printer to send e-mails to yourself only. |
| Use cc:/bcc: Off* On | Enable carbon copy and blind carbon copy in e-mail. |
| Use Multi-Page TIFF Off On* | Enable scanning of multiple TIFF images in one TIFF file. |
| TIFF Compression JPEG LZW* | Specify the compression type for TIFF files. |
| Text Default 5–95 (75*) | Set the text quality in the content being scanned. |
| Text/Photo Default 5–95 (75*) | Set the text and photo quality in the content being scanned. |
| Photo Default 5–95 (50*) | Set the photo quality of the content being scanned. |
| Adjust ADF Skew Off On* | Set the printer to adjust the skewed images from documents that are scanned from the ADF. |
| Transmission Log Print log* Do Not Print Log Print Only For Error | Print a transmission log for e-mail scans. |
| Log Paper Source Tray [x] (1*) Multipurpose Feeder | Specify the paper source for printing e-mail logs. |
| Custom Job Scanning Off* On | Set the printer to scan the first set of original documents using the specified settings, and then scan the next set with the same or different settings. Note: This menu item appears only when a hard disk or an ISD is installed. |
| Note: An asterisk (*) next to a value indicates the factory default setting. | |

| Menu item | Description |
|---|--|
| Scan Preview Off* On | Show a scan preview of the original document. Note: This menu item appears only when a hard disk or an ISD is installed. |
| Allow Save as Shortcut Off On* | Save an e-mail address as a shortcut. |
| E-mail Images Sent As Attachment* Web Link | Specify how to send the images that are included in the e-mail. |
| Reset E-mail Information After Sending Off On* | Reset the To, Subject, Message, and Filename fields to their default values after sending an e-mail. |
| Note: An asterisk (*) next to a value indicates the factory default setting. | |

Web Link Setup

| Menu item | Description |
|------------------|---|
| Server | Specify the credentials of the server that is hosting the images that are included in the e-mail. |
| Login | |
| Password | |
| Path | |
| File Name | |
| Web Link | |

FTP

FTP Defaults

| Menu item | Description |
|--|--|
| Format JPEG (.jpg) PDF (.pdf)* TIFF (.tif) XPS (.xps) TXT (.txt) RTF (.rtf) DOCX (.docx) XLSX (.xlsx) CSV (.csv) | Specify the file format for the scanned image. Note: TXT (.txt), RTF (.rtf), DOCX (.docx), XLSX (.xlsx), and CSV (.csv) appear only if you have purchased and installed an OCR solution. |
| Global OCR Settings Recognized Languages Auto Rotate (Off*) Despeckle (Off*) Auto Contrast Enhance (Off*) | Configure the settings for optical character recognition (OCR). Note: This menu item appears only if you have purchased and installed an OCR solution. |
| PDF Settings PDF Version (1.5*) Archival Version (A-1a*) Highly Compressed (Off*) Secure (Off*) Searchable (Off*) Archival (PDF/A) (Off*) | Configure the PDF settings for the scanned image. Notes: <ul style="list-style-type: none"> • Archival Version and Archival (PDF/A) are supported only when PDF Version is set to 1.4. • Highly Compressed appears only when a hard disk or an intelligent storage drive (ISD) is installed. • Searchable appears only if you have purchased and installed an OCR solution. |
| Content Type Text Text/Photo* Graphics Photo | Improve the output result based on the content type of the original document. |
| Content Source Black and White Laser* Color Laser Inkjet Photo/Film Magazine Newspaper Press Other | Improve the output result based on the content source of the original document. |
| Note: An asterisk (*) next to a value indicates the factory default setting. | |

| Menu item | Description |
|---|--|
| Color Black and White Gray Color* Auto | Set the printer to capture file content in color or in mono. |
| Resolution 75 dpi 150 dpi* 200 dpi 300 dpi 400 dpi 600 dpi | Set the resolution of the scanned image. |
| Darkness 1–9 (5*) | Adjust the darkness of the scanned image. |
| Orientation Portrait* Landscape | Specify the orientation of the original document. |
| Original Size Mixed Sizes* | Set the paper size of the original document. |
| Sides Off* Long Edge Short Edge | Specify the orientation when scanning on both sides of the document. |
| File Name | Specify the file name of the scanned image. |
| Note: An asterisk (*) next to a value indicates the factory default setting. | |

Advanced Imaging

| Menu item | Description |
|--|---|
| Color Balance Cyan - Red (0*) Magenta - Green (0*) Yellow - Blue (0*) | Adjust the color intensity for cyan, magenta, and yellow. |
| Color Dropout Color Dropout (None*) Default Red Threshold (128*) Default Green Threshold (128*) Default Blue Threshold (128*) | Specify which color to drop during scanning, and adjust the dropout setting for that color. |
| Note: An asterisk (*) next to a value indicates the factory default setting. | |

| Menu item | Description |
|---|---|
| Auto Color Detect Color Sensitivity (5*) Area Sensitivity (5*) FTP Bit Depth (1 bit*) Minimum Scan Resolution (300 dpi*) | Configure the auto color detection setting. |
| JPEG Quality Best for content* 5–95 | Set the JPEG quality of the scanned image. |
| Contrast Best for content* 0 1 2 3 4 5 | Specify the contrast for the scanned image. |
| Background Removal Background Detection (Content-based*) Level (0*) | Remove the background color or image noise from the original document. Notes: <ul style="list-style-type: none"> • Content-based removes the background color from the original document. • Fixed removes image noise from a photo. |
| Mirror Image Off* On | Create a mirror image of the original document. |
| Negative Image Off* On | Create a negative image of the original document. |
| Shadow Detail -4 to 4 (0*) | Adjust the shadow detail in the scanned image. |
| Scan Edge to Edge Off* On | Allow edge-to-edge scanning of the original document. |
| Sharpness 1–5 (3*) | Adjust the sharpness in the scanned image. |
| Temperature -4 to 4 (0*) | Generate a bluer or redder output of the original document. |
| Blank Pages Blank Page Removal (Do Not Remove*) Blank Page Sensitivity (5*) | Set the sensitivity of scans in relation to blank pages in the original document. |
| Note: An asterisk (*) next to a value indicates the factory default setting. | |

Admin Controls

| Menu item | Description |
|---|--|
| Text Default 5–95 (75*) | Set the quality of text on the scanned image. |
| Text/Photo Default 5–95 (75*) | Set the quality of text and photo on the scanned image. |
| Photo Default 5–95 (50*) | Set the quality of photo on the scanned image. |
| Use Multi-Page TIFF On* Off | Enable scanning of multiple TIFF images in one TIFF file. |
| TIFF Compression LZW* JPEG | Specify the compression type for TIFF files. |
| Transmission Log Print Log* Do Not Print Log Print Only For Error | Print a transmission log for FTP scans. |
| Log Paper Source Tray [x] (1*) Multipurpose Feeder | Specify the paper source for printing FTP logs. |
| Custom Job Scanning Off* On | Set the printer to scan the first set of original documents using the specified settings, and then scan the next set with the same or different settings. Note: This menu item appears only when a hard disk or an ISD is installed. |
| Scan Preview Off* On | Show a preview of the original document. Note: This menu item appears only when a hard disk or an ISD is installed. |
| Allow Save as Shortcut Off On* | Save an FTP address as a shortcut. |
| Adjust ADF Skew Off* On | Set the printer to adjust the skewed images from documents that are scanned from the ADF. |
| Use Passive FTP Off* On | Let the FTP server specify the data port that the printer connects to. |
| Note: An asterisk (*) next to a value indicates the factory default setting. | |

USB Drive

Flash Drive Scan

| Menu item | Description |
|--|---|
| Format JPEG (.jpg) PDF (.pdf)* TIFF (.tif) XPS (.xps) TXT (.txt) RTF (.rtf) DOCX (.docx) XLSX (.xlsx) CSV (.csv) | Specify the file format for the scanned image. Note: TXT (.txt), RTF (.rtf), DOCX (.docx), XLSX (.xlsx), and CSV (.csv) appear only if you have purchased and installed an OCR solution. |
| Global OCR Settings Recognized Languages Auto Rotate (Off*) Despeckle (Off*) Auto Contrast Enhance (Off*) | Configure the settings for optical character recognition (OCR). Note: This menu item appears only if you have purchased and installed an OCR solution. |
| PDF Settings PDF Version (1.5*) Archival Version (A-1a*) Highly Compressed (Off*) Secure (Off*) Searchable (Off*) Archival (PDF/A) (Off*) | Configure the PDF settings of the scanned image. Notes: <ul style="list-style-type: none"> • Archival Version and Archival (PDF/A) are supported only when PDF Version is set to 1.4. • Highly Compressed appears only when a hard disk or an intelligent storage drive (ISD) is installed. • Searchable appears only if you have purchased and installed an OCR solution. |
| Content Type Text Text/Photo* Graphics Photo | Improve the output result based on the content type of the original document. |
| Content Source Black and White Laser* Color Laser Inkjet Photo/Film Magazine Newspaper Press Other | Improve the output result based on the content source of the original document. |
| Note: An asterisk (*) next to a value indicates the factory default setting. | |

| Menu item | Description |
|---|---|
| Color Black and White Gray Color* Auto | Set the printer to capture file content in color or in mono. |
| Resolution 75 dpi 150 dpi* 200 dpi 300 dpi 400 dpi 600 dpi | Set the resolution of the scanned image. |
| Darkness 1–9 (5*) | Adjust the darkness of the scanned image. |
| Orientation Portrait* Landscape | Specify the orientation of the original document. |
| Original Size Mixed Sizes* | Set the paper size of the original document. |
| Sides Off* Long edge Short edge | Specify the orientation of the original document when scanning on both sides of the document. |
| File Name | Specify the file name of the scanned image. |
| Note: An asterisk (*) next to a value indicates the factory default setting. | |

Advanced Imaging

| Menu item | Description |
|--|---|
| Color Balance Cyan - Red (0*) Magenta - Green (0*) Yellow - Blue (0*) | Adjust the color intensity for cyan, magenta, and yellow. |
| Color Dropout Color Dropout (None*) Default Red Threshold (128*) Default Green Threshold (128*) Default Blue Threshold (128*) | Specify which color to drop during scanning, and adjust the dropout setting for that color. |
| Note: An asterisk (*) next to a value indicates the factory default setting. | |

| Menu item | Description |
|--|---|
| Auto Color Detect Color Sensitivity (5*) Area Sensitivity (5*) Scan Bit Depth (1 bit*) Minimum Scan Resolution (300 dpi*) | Configure the auto color detection setting. |
| JPEG Quality Best for content* 5–95 | Set the JPEG quality of the scanned image. |
| Contrast Best for content* 0–5 | Specify the contrast for the scanned image. |
| Background Removal Background Detection (Content-based*) Level (0*) | Remove the background color or image noise from the original document. Notes: <ul style="list-style-type: none"> • Content-based removes the background color from the original document. • Fixed removes image noise from a photo. |
| Mirror Image Off* On | Create a mirror image of the original document. |
| Negative Image Off* On | Create a negative image of the original document. |
| Shadow Detail -4 to 4 (0*) | Adjust the shadow detail in the scanned image. |
| Scan Edge to Edge Off* On | Scan the original document from edge to edge. |
| Sharpness 1–5 (3*) | Adjust the sharpness in the scanned image. |
| Temperature -4 to 4 (0*) | Generate a bluer or redder output of the original document. |
| Blank Pages Blank Page Removal (Do Not Remove*) Blank Page Sensitivity (5*) | Set the sensitivity of scans in relation to blank pages in the original document. |
| Note: An asterisk (*) next to a value indicates the factory default setting. | |

Admin Controls

| Menu item | Description |
|---|--|
| Text Default 5–95 (75*) | Set the quality of text on the scanned image. |
| Text/Photo Default 5–95 (75*) | Set the quality of text and photo on the scanned image. |
| Photo Default 5–95 (50*) | Set the quality of a photo on the scanned image. |
| Use Multi-Page TIFF Off On* | Enable scanning of multiple TIFF images in one TIFF file. |
| TIFF Compression LZW* JPEG | Specify the compression type for TIFF files. |
| Custom Job Scanning Off* On | Set the printer to scan the first set of original documents using the specified settings, and then scan the next set with the same or different settings. Note: This menu item appears only when a hard disk or an ISD is installed. |
| Scan Preview Off* On | Show a scan preview of the original document. Note: This menu item appears only when a hard disk or an ISD is installed. |
| Adjust ADF Skew Off* On | Set the printer to adjust the skewed images from documents that are scanned from the ADF. |
| Note: An asterisk (*) next to a value indicates the factory default setting. | |

Flash Drive Print

| Menu item | Description |
|--|---|
| Number of Copies 1–9999 (1*) | Set the number of copies. |
| Paper Source Tray [x] (1*) Multipurpose Feeder Manual Paper Manual Envelope | Set the paper source for the print job. |
| Collate Off [1,1,1,2,2,2] On [1,2,1,2,1,2]* | Keep the pages of a print job stacked in sequence, particularly when printing multiple copies of the job. |
| Note: An asterisk (*) next to a value indicates the factory default setting. | |

| Menu item | Description |
|---|---|
| Sides 1-Sided* 2-Sided | Specify whether to print on one side or both sides of the paper. |
| Flip Style Long Edge* Short Edge | Determine which side of the paper is bound when performing two-sided printing. |
| Pages per Side Off* 2 pages per side 3 pages per side 4 pages per side 6 pages per side 9 pages per side 12 pages per side 16 pages per side | Print multiple page images on one side of a sheet of paper. |
| Pages per Side Ordering Horizontal* Reverse Horizontal Reverse Vertical Vertical | Specify the positioning of multiple page images when using Pages per Side menu. |
| Pages per Side Orientation Auto* Landscape Portrait | Specify the orientation of multiple page images when using Pages per Side menu. |
| Pages per Side Border None* Solid | Print a border around each page image when using Pages per Side menu. |
| Separator Sheets Off* Between Copies Between Jobs Between Pages | Insert blank separator sheets when printing. |
| Separator Sheet Source Tray [x] (1*) Multipurpose Feeder | Specify the paper source for the separator sheet. |
| Blank Pages Do Not Print* Print | Print blank pages in a print job. |
| Note: An asterisk (*) next to a value indicates the factory default setting. | |

Network/Ports

Network Overview

| Menu item | Description |
|---|---|
| Active Adapter Auto* Standard Network Wireless | Specify the type of the network connection. Note: Wireless is available only in printers connected to a wireless network. |
| Network Status | Show the connectivity status of the printer network. |
| Display Network Status on Printer Off On* | Show the network status on the display. |
| Speed, Duplex | Show the speed of the currently active network card. |
| IPv4 | Show the IPv4 address. |
| All IPv6 Addresses | Show all IPv6 addresses. |
| Reset Print Server | Reset all active network connections to the printer. Note: This setting removes all network configuration settings. |
| Network Job Timeout Off On* (90 seconds) | Set the time before the printer cancels a network print job. |
| Banner Page Off* On | Print a banner page. |
| Scan to PC Port Range | Specify a valid port range for printers that are behind a port blocking firewall. |
| Enable Network Connections Off On* | Enable the printer to connect to a network. |
| Enable LLDP Off* On | Enable Link Layer Discovery Protocol (LLDP) in the printer. |
| Note: An asterisk (*) next to a value indicates the factory default setting. | |

Wireless

Note: This menu is available only in printers connected to a Wi-Fi network or printers that have a wireless network adapter.

| Menu item | Description |
|---|--|
| Setup On Printer Panel Choose Network Add Wi-Fi Network Network Name Network Mode Infrastructure Wireless Security Mode Disabled* WPA2/WPA - Personal WPA2 - Personal WPA2/WPA3 - Personal WPA3 - Personal 802.1x - RADIUS | Configure the Wi-Fi connection using the control panel. Note: This menu item appears as <i>Wireless Connection Setup</i> in the Embedded Web Server. |
| Wi-Fi Protected Setup Start Push Button Method Start PIN Method | Establish a Wi-Fi network and enable network security. Notes: <ul style="list-style-type: none"> • Start Push Button Method connects the printer to a Wi-Fi network when buttons on both the printer and the access point (wireless router) are pressed within a given time. • Start PIN Method connects the printer to a Wi-Fi network when a PIN on the printer is entered into the wireless settings of the access point. |
| Compatibility 802.11b/g/n (2.4GHz)* 802.11a/b/g/n/ac (2.4GHz/5GHz) 802.11a/n/ac (5GHz) | Specify the standard for the Wi-Fi network. Note: 802.11a/b/g/n/ac (2.4GHz/5GHz) and 802.11a/n/ac (5GHz) only appear when a Wi-Fi option is installed. |
| Wireless Security Mode Disabled* WPA2/WPA-Personal WPA2-Personal WPA2/WPA3 - Personal WPA3 - Personal 802.1x - RADIUS | Set the security mode for connecting the printer to Wi-Fi devices. |
| WPA2/WPA Personal AES* | Enable Wi-Fi security through Wi-Fi Protected Access (WPA). Note: This menu item appears only when the Wireless Security Mode is set to WPA2/WPA-Personal. |
| Set PSK | Set the password for secure Wi-Fi connection. |
| WPA2-Personal AES* | Enable Wi-Fi security through WPA2. Note: This menu item appears only when the Wireless Security Mode is set to WPA2-Personal. |

| Menu item | Description |
|--|--|
| 802.1x Encryption Mode WPA+ WPA2* WPA2 + PMF* | Enable Wi-Fi security through 802.1x standard. Note: This menu item appears only when the Wireless Security Mode is set to 802.1x - RADIUS. |
| IPv4 Enable DHCP On* Off Set Static IP Address IP Address Netmask Gateway | Enable and configure IPv4 settings in the printer. |
| IPv6 Enable IPv6 On* Off Enable DHCPv6 On Off* Stateless Address Autoconfiguration On* Off DNS Server Address Manually Assigned IPv6 Address Manually Assigned IPv6 Router Address Prefix All IPv6 Addresses All IPv6 Router Addresses | Enable and configure IPv6 settings in the printer. |
| Network Address UAA LAA | View the network addresses. |
| PCL SmartSwitch On* Off | Set the printer to switch automatically to PCL emulation when a print job requires it, regardless of the default printer language. Note: If PCL SmartSwitch is off, then the printer does not examine incoming data and uses the default printer language specified in the Setup menu. |
| PS SmartSwitch On* Off | Set the printer to switch automatically to PS emulation when a print job requires it, regardless of the default printer language. Note: If PS SmartSwitch is off, then the printer does not examine incoming data and uses the default printer language specified in the Setup menu. |

| Menu item | Description |
|--|---|
| Job Buffering On Off* | Temporarily store print jobs in the hard disk or intelligent storage drive (ISD) before printing. Note: This menu item appears only when a hard disk or an ISD is installed. |
| Mac Binary PS Auto* On Off | Set the printer to process Macintosh binary PostScript print jobs. Notes: <ul style="list-style-type: none"> • On processes raw binary PostScript print jobs. • Off filters print jobs using the standard protocol. |

Wi-Fi Direct

Note: This menu is available only in printers connected to a Wi-Fi network or printers that have a wireless network adapter.

| Menu item | Description |
|---|--|
| Enable Wi-Fi Direct On Off* | Set the printer to connect directly to Wi-Fi devices. |
| Wi-Fi Direct Name | Specify the name of the Wi-Fi Direct network. |
| Wi-Fi Direct Password | Set the password to authenticate and validate users on a Wi-Fi connection. |
| Show Password on Setup Page Off On* | Show the Wi-Fi Direct Password on the Network Setup Page. |
| Preferred Channel Number 1–11 Auto* | Set the preferred channel of the Wi-Fi network. |
| Group Owner IP Address | Specify the IP address of the group owner. |
| Auto-Accept Push Button Requests Off* On | Accept requests to connect to the network automatically. Note: Accepting clients automatically is not secured. |
| Note: An asterisk (*) next to a value indicates the factory default setting. | |

AirPrint

Note: This menu appears only in the Embedded Web Server.

| Menu item | Description |
|---|---|
| All AirPrint Functions | Show the AirPrint status of the printer. |
| Enable AirPrint On* Off | Enable the AirPrint feature. Note: This menu item appears only if Internet Printing Protocol (IPP) or mDNS is disabled. |
| Enable iBeacon On Off* | Enable the iBeacon feature. |
| Bonjour Name | Identify printer designation and location. |
| Organization Name | |
| Organizational Unit | |
| Printer Location | |
| Printer's Latitude | |
| Printer's Longitude | |
| Printer's Altitude | |
| More Options | |
| Note: An asterisk (*) next to a value indicates the factory default setting. | |

Mobile Services Management

| Menu item | Description |
|---|--|
| Enable IPP Print On* Off | Allow printing from mobile devices using Internet Printing Protocol (IPP). |
| Enable IPP Fax On* Off | Allow sending faxes using Internet Printing Protocol (IPP). |
| Enable IPP Over USB On* Off | Allow print or scan jobs using USB connection. |
| Enable Scan On* Off | Allow scanning using eSCL protocol. |
| Note: An asterisk (*) next to a value indicates the factory default setting. | |

Ethernet

| Menu item | Description |
|---|---|
| Network Speed | Show the speed of the active network adapter. |
| IPv4 Enable DHCP (On*) Set Static IP Address | Configure the IPv4 settings. |
| IPv6 Enable IPv6 (On*) Enable DHCPv6 (Off*) Stateless Address Autoconfiguration (On*) DNS Server Address Manually Assigned IPv6 Address Manually Assigned IPv6 Router Address Prefix (64*) All IPv6 Addresses All IPv6 Router Addresses | Configure the IPv6 settings. |
| Network Address UAA LAA | Specify the network address. |
| PCL SmartSwitch Off On* | Set the printer to switch automatically to PCL emulation when a print job requires it, regardless of the default printer language. Note: When this setting is disabled, the printer does not examine incoming data and uses the default printer language specified in the Setup menu. |
| PS SmartSwitch Off On* | Set the printer to switch automatically to PostScript emulation when a print job requires it, regardless of the default printer language. Note: When this setting is disabled, the printer does not examine incoming data and uses the default printer language specified in the Setup menu. |
| Job Buffering Off* On | Temporarily store print jobs in the hard disk or intelligent storage drive (ISD) before printing. Note: This menu item appears only when a hard disk or an ISD is installed. |
| Mac Binary PS Auto* On Off | Set the printer to process Macintosh binary PostScript print jobs. Notes: <ul style="list-style-type: none"> • Auto processes print jobs from computers using either Windows or Macintosh operating systems. • Off filters PostScript print jobs using the standard protocol. |
| Note: An asterisk (*) next to a value indicates the factory default setting. | |

| Menu item | Description |
|---|--|
| Energy Efficient Ethernet On Off Auto* | Reduce power consumption when the printer does not receive data from the Ethernet network. |
| Note: An asterisk (*) next to a value indicates the factory default setting. | |

TCP/IP

Note: This menu appears only in network printers or printers attached to print servers.

| Menu item | Description |
|---|---|
| Set Hostname | Set the current TCP/IP host name. |
| Domain Name | Set the domain name. |
| Allow DHCP/BOOTP to update NTP server On* Off | Allow the DHCP and BOOTP clients to update the NTP settings of the printer. |
| Zero Configuration Name | Specify a service name for the zero configuration network. |
| Enable Auto IP Off On* | Assign an IP address automatically. |
| DNS Server Address | Specify the current Domain Name System (DNS) server address. |
| Backup DNS Server Address | Specify the backup DNS server addresses. |
| Backup DNS Server Address 2 | |
| Backup DNS Server Address 3 | |
| Domain Search Order | Specify a list of domain names to locate the printer and its resources that reside in different domains on the network. |
| Enable DDNS Off* On | Update the Dynamic DNS settings. |
| DDNS TTL | Specify the current DDNS settings. |
| Default TTL | |
| DDNS Refresh Time | |
| Enable mDNS Off On* | Update the multicast DNS settings. |
| WINS Server Address | Specify a server address for Windows Internet Name Service (WINS). |
| Note: An asterisk (*) next to a value indicates the factory default setting. | |

| Menu item | Description |
|--|--|
| Enable BOOTP Off* On | Allow the BOOTP to assign a printer IP address. |
| Restricted Server List | Specify the IP addresses that are allowed to communicate with the printer over TCP/IP. Notes: <ul style="list-style-type: none"> • Use a comma to separate each IP address. • You can add up to 50 IP addresses. |
| Restricted Server List Options Block All Ports* Block Printing Only Block Printing and HTTP Only | Specify the access option for IP addresses that are not in the list. |
| MTU 256–1500 Ethernet (1500*) | Specify a maximum transmission unit (MTU) parameter for the TCP connections. |
| Raw Print Port 1–65535 (9100*) | Specify a raw port number for printers connected on a network. |
| Outbound Traffic Maximum Speed Off* On | Set the maximum transfer rate of the printer. Note: When enabled, the option for this setting is 100–1000000 Kilobits/second. |
| TLS Support Enable TLSv1.0 (Off) Enable TLSv1.1 (Off*) Enable TLSv1.2 (On*) | Enable the Transport Layer Security protocol. |
| SSL Cipher List | Specify the cipher algorithms to use for the SSL or the TLS connections. |
| TLSv1.3 SSL Cipher List | |
| Note: An asterisk (*) next to a value indicates the factory default setting. | |

SNMP

Note: This menu appears only in network printers or printers that are attached to print servers.

| Menu item | Description |
|---|--|
| SNMP Versions 1 and 2c Enabled Off On* Allow SNMP Set Off On* Enable PPM MIB Off On* SNMP Community | Configure Simple Network Management Protocol (SNMP) versions 1 and 2c to install print drivers and applications. |
| SNMP Version 3 Enabled Off On* Context Name Set Read/Write Credentials User Name Authentication Password Privacy Password Set Read-only Credentials User Name Authentication Password Privacy Password Authentication Hash MD5 SHA1* Minimum Authentication Level No Authentication, No Privacy Authentication, No Privacy Authentication, Privacy* Privacy Algorithm DES AES-128* | Configure SNMP version 3 to install and update the printer security. |
| Note: An asterisk (*) next to a value indicates the factory default setting. | |

IPSec

Note: This menu appears only in network printers or printers that are attached to print servers.

| Menu item | Description |
|--|--|
| Enable IPsec Off* On | Enable Internet Protocol Security (IPsec). |
| Base Configuration Default* Compatibility Secure | Set the IPsec base configuration. Note: This menu item appears only when Enable IPsec is set to On. |
| DH (Diffie-Hellman) Group Proposal modp2048 (14)* modp3072 (15) modp4096 (16) modp6144 (17) | Set the IPsec base configuration. Note: This menu item appears only when Base Configuration is set to Compatibility. |
| Proposed Encryption Method 3DES AES* | Set the encryption method. Note: This menu item appears only when Base Configuration is set to Compatibility. |
| Proposed Authentication Method SHA1 SHA256* SHA512 | Set the authentication method. Note: This menu item appears only when Base Configuration is set to Compatibility. |
| IKE SA Lifetime (Hours) 1 2 4 8 24* | Specify the IKE SA expiry period. Note: This menu item appears only when Base Configuration is set to Secure. |
| IPsec SA Lifetime (Hours) 1 2 4 8* 24 | Specify the IPsec SA expiry period. Note: This menu item appears only when Base Configuration is set to Secure. |
| IPsec Device Certificate | Specify an IPsec certificate. Note: This menu item appears only when Enable IPsec is set to On. |
| Pre-Shared Key Authenticated Connections Host [x] | Configure the authenticated connections of the printer. Note: These menu items appear only when Enable IPsec is set to On. |
| Certificate Authenticated Connections Host [x] Address[/subnet] | |
| Note: An asterisk (*) next to a value indicates the factory default setting. | |

802.1x

Note: This menu appears only in network printers or printers that are attached to print servers.

| Menu item | Description |
|--|---|
| Active Off* On | Let the printer join networks that require authentication before allowing access. |
| 802.1x Authentication Device Login Name Device Login Password Validate Serve Certificate (On*) Enable Event Logging (Off*) 802.1x Device Certificate | Configure the settings for authenticating the 802.1x connection. |
| Authentication Mechanisms EAP - MD5 (On*) EAP - MSCHAPv2 (On*) LEAP (On*) PEAP (On*) EAP - TLS (On*) EAP - TTLS (On*) TTLS Authentication Method (MSCHAPv2*) | Configure the allowed authentication mechanisms for the 802.1x connection. |
| Note: An asterisk (*) next to a value indicates the factory default setting. | |

LPD Configuration

Note: This menu appears only in network printers or printers that are attached to print servers.

| Menu item | Description |
|---|---|
| LPD Timeout 0–65535 seconds (90*) | Set the time-out value to stop the Line Printer Daemon (LPD) server from waiting indefinitely for hung or invalid print jobs. |
| LPD Banner Page Off* On | Print a banner page for all LPD print jobs. Note: A banner page is the first page of a print job used as a separator of print jobs and to identify the originator of the print job request. |
| LPD Trailer Page Off* On | Print a trailer page for all LPD print jobs. Note: A trailer page is the last page of a print job. |
| LPD Carriage Return Conversion Off* On | Enable carriage return conversion. Note: Carriage return is a mechanism that commands the printer to move the position of the cursor to the first position on the same line. |
| Note: An asterisk (*) next to a value indicates the factory default setting. | |

HTTP/FTP Settings

| Menu item | Description |
|--|--|
| Proxy HTTP Proxy IP Address HTTP Default IP Port FTP Proxy IP Address FTP Default IP Port Authentication User Name Password Local Domains | Configure the HTTP and FTP server settings. |
| Other Settings Enable HTTP Server (On*) | Access the Embedded Web Server to monitor and manage the printer. |
| Other Settings Enable HTTPS (On*) | Enable Hypertext Transfer Protocol Secure (HTTPS) to encrypt data transferring to and from the print server. |
| Other Settings Force HTTPS Connections (Off*) | Force the printer to use HTTPS connections. |
| Other Settings Enable FTP/TFTP (On*) | Send files using FTP/TFTP. |
| Other Settings HTTPS Device Certificate (default*) | View the HTTP device certificate used on the printer. |
| Other Settings Timeout for HTTP/FTP Requests (30*) | Specify the amount of time before the server connection stops. |
| Other Settings Retries for HTTP/FTP Requests (3*) | Set the number of retries to connect to the HTTP/FTP server. |
| Note: An asterisk (*) next to a value indicates the factory default setting. | |

ThinPrint

| Menu item | Description |
|---|--|
| Enable ThinPrint Off* On | Print using ThinPrint. |
| Port Number 4000–4999 (4000*) | Set the port number for the ThinPrint server. |
| Bandwidth (bits/sec) 100–1000000 (0*) | Set the speed to transmit data in a ThinPrint environment. |
| Packet Size (kbytes) 0–64000 (0*) | Set the packet size for data transmission. |
| Note: An asterisk (*) next to a value indicates the factory default setting. | |

USB

| Menu item | Description |
|---|--|
| PCL SmartSwitch Off On* | Set the printer to switch to PCL emulation when a print job received through a USB port requires it, regardless of the default printer language. Note: When this setting is disabled, the printer does not examine incoming data and uses the default printer language specified in the Setup menu. |
| PS SmartSwitch Off On* | Set the printer to switch to PostScript emulation when a print job received through a USB port requires it, regardless of the default printer language. Note: When this setting is disabled, the printer does not examine incoming data and uses the default printer language specified in the Setup menu. |
| Job Buffering Off* On | Temporarily store print jobs in the hard disk or intelligent storage drive (ISD) before printing. Note: This menu item appears only when a hard disk or an ISD is installed. |
| Mac Binary PS Auto* On Off | Set the printer to process Macintosh binary PostScript print jobs. Notes: <ul style="list-style-type: none"> • Auto processes print jobs from computers using either Windows or Macintosh operating systems. • Off filters PostScript print jobs using the standard protocol. |
| Enable USB Port Off On* | Enable the front USB drive port. |
| Note: An asterisk (*) next to a value indicates the factory default setting. | |

Restrict external network access

| Menu item | Description |
|---|--|
| Restrict external network access Off* On | Restrict access to network sites. |
| External network address | Specify the network addresses with restricted access. |
| E-mail address for notification | Specify an e-mail address to send a notification of logged events. |
| Ping frequency 1–300 (10*) | Specify the network query interval in seconds. |
| Subject | Specify the subject and message of the notification e-mail. |
| Message | |
| Note: An asterisk (*) next to a value indicates the factory default setting. | |

Security

Login Methods

Manage Permissions

| Menu item | Description |
|---|---|
| <p>Function Access</p> <ul style="list-style-type: none"> Access Address Book in Apps Modify Address Book Manage Shortcuts Create Profiles Manage Bookmarks Flash Drive Print Flash Drive Scan Copy Function Color Dropout E-mail Function Fax Function FTP Function Release Held Faxes Held Jobs Access User Profiles Cancel Jobs at the Device Change Language Internet Printing Protocol (IPP) Initiate Scans Remotely B/W Print Network Folder - Scan | <p>Control access to the printer functions.</p> |
| <p>Administrative Menus</p> <ul style="list-style-type: none"> Security Menu Network/Ports Menu Paper Menu Reports Menu Function Configuration Menus Supplies Menu Option Card Menu SE Menu Device Menu | <p>Control access to the printer menu settings.</p> |

| Menu item | Description |
|--|--|
| <p>Device Management</p> <ul style="list-style-type: none"> Remote Management Firmware Updates Apps Configuration Operator Panel Lock Embedded Web Server Access Import / Export All Settings Out of Service Erase | <p>Control access to the printer management options.</p> |
| <p>Apps</p> <ul style="list-style-type: none"> New Apps Scan Center Scan Center Custom [x] | <p>Control access to printer applications.</p> |

Local Accounts

| Menu item | Description |
|---|--|
| <p>Manage Groups/Permissions</p> <ul style="list-style-type: none"> Add Group <ul style="list-style-type: none"> Import Access Controls Function Access Administrative Menus Device Management All Users <ul style="list-style-type: none"> Import Access Controls Function Access Administrative Menus Device Management Admin | <p>Control group or user access to the printer functions, applications, and security settings.</p> |
| <p>Add User</p> <ul style="list-style-type: none"> User Name/Password User Name Password PIN | <p>Create local accounts to manage access to the printer functions.</p> |
| <p>User Name/Password Accounts</p> <ul style="list-style-type: none"> Add User | |
| <p>User Name Accounts</p> <ul style="list-style-type: none"> Add User | |
| <p>Password Accounts</p> <ul style="list-style-type: none"> Add User | |
| <p>PIN Accounts</p> <ul style="list-style-type: none"> Add User | |

Schedule USB Devices

| Menu item | Description |
|--------------------------------------|--|
| Schedules Add New Schedule | Schedule access to the front USB port. |

Security Audit Log

| Menu item | Description |
|---|---|
| Enable Audit Off* On | Record the events in the secure audit log and remote syslog. |
| Enable Remote Syslog Off* On | Send audit logs to a remote server. |
| Remote Syslog Server | Specify the remote syslog server. |
| Remote Syslog Port 1–65535 (514*) | Specify the remote syslog port. |
| Remote Syslog Method Normal UDP* Stunnel | Specify a syslog method to transmit logged events to a remote server. |
| Note: An asterisk (*) next to a value indicates the factory default setting. | |

| Menu item | Description |
|--|--|
| <p>Remote Syslog Facility</p> <ul style="list-style-type: none"> 0 - Kernel Messages 1 - User-Level Messages 2 - Mail System 3 - System Daemons 4 - Security/Authorization Messages* 5 - Messages Generated Internally by Syslogs 6 - Line Printer Subsystem 7 - Network News Subsystem 8 - UUCP Subsystem 9 - Clock Daemon 10 - Security/Authorization Messages 11 - FTP Daemon 12 - NTP Subsystem 13 - Log Audit 14 - Log Alert 15 - Clock Daemon 16 - Local Use 0 (local0) 17 - Local Use 1 (local1) 18 - Local Use 2 (local2) 19 - Local Use 3 (local3) 20 - Local Use 4 (local4) 21 - Local Use 5 (local5) 22 - Local Use 6 (local6) 23 - Local Use 7 (local7) | <p>Specify a facility code that the printer uses when sending log events to a remote server.</p> |
| <p>Severity of Events to Log</p> <ul style="list-style-type: none"> 0 - Emergency 1 - Alert 2 - Critical 3 - Error 4 - Warning* 5 - Notice 6 - Informational 7 - Debug | <p>Specify the priority level cutoff for logging messages and events.</p> |
| <p>Remote Syslog Non-Logged Events</p> <ul style="list-style-type: none"> Off* On | <p>Send all events, regardless of severity level, to the remote server.</p> |
| <p>Admin's E-mail Address</p> | <p>Send e-mail notification of logged events to the administrator.</p> |
| <p>Note: An asterisk (*) next to a value indicates the factory default setting.</p> | |

| Menu item | Description |
|---|---|
| E-mail Log Cleared Alert Off* On | Send e-mail notification to the administrator when a log entry is deleted. |
| E-mail Log Wrapped Alert Off* On | Send e-mail notification to the administrator when the log becomes full and begins to overwrite the oldest entries. |
| Log Full Behavior Wrap Over Oldest Entries* E-mail Log Then Delete All Entries | Resolve log storage issues when the log fills its allotted memory. |
| E-mail % Full Alert Off* On | Send e-mail notification to the administrator when the log fills its allotted memory. |
| % Full Alert Level 1–99 (90*) | |
| E-mail Log Exported Alert Off* On | Send e-mail notification to the administrator when a log is exported. |
| E-mail Log Settings Changed Alert Off* On | Send e-mail notification to the administrator when Enable Audit is set. |
| Log Line Endings LF (\n)* CR (\r) CRLF (\r\n) | Specify how the log file terminates the end of each line. |
| Digitally Sign Exports Off* On | Add a digital signature to each exported log file. |
| Clear Log | Delete all audit logs. |
| Export Log Syslog (RFC 5424) Syslog (RFC 3164) CSV | Export a security log to a flash drive. |
| Note: An asterisk (*) next to a value indicates the factory default setting. | |

Login Restrictions

| Menu item | Description |
|---|---|
| Login failures 1–10 (3*) | Specify the number of failed login attempts before the user gets locked out. |
| Failure time frame 1–60 minutes (5*) | Specify the time frame between failed login attempts before the user gets locked out. |
| Lockout time 1–60 minutes (5*) | Specify the lockout duration. |
| Web Login Timeout 1–120 minutes (10*) | Specify the delay for a remote login before the user is logged off automatically. |
| Note: An asterisk (*) next to a value indicates the factory default setting. | |

Confidential Print Setup

| Menu item | Description |
|---|--|
| Max Invalid PIN 2–10 | Set the limit for entering an invalid PIN. Note: When the limit is reached, the print jobs for that user name are deleted. |
| Confidential Job Expiration Off* 1 Hour 4 Hours 24 Hours 1 Week | Set an individual expiration time for each held job before it is automatically deleted from the hard disk or intelligent storage drive. Note: A held job is either Confidential, Repeat, Reserve, or Verify. |
| Repeat Job Expiration Off* 1 Hour 4 Hours 24 Hours 1 Week | Set the expiration time for a print job that you want to repeat. |
| Verify Job Expiration Off* 1 Hour 4 Hours 24 Hours 1 Week | Set the expiration time for printing a copy of a job for you to check its quality before printing the remaining copies. |
| Reserve Job Expiration Off* 1 Hour 4 Hours 24 Hours 1 Week | Set the expiration time for jobs that you want to store in the printer for printing later. |
| Note: An asterisk (*) next to a value indicates the factory default setting. | |

| Menu item | Description |
|---|--|
| Require All Jobs to be Held Off* On | Set the printer to hold all print jobs. |
| Keep duplicate documents Off* On | Set the printer to keep all documents with the same file name. |
| Note: An asterisk (*) next to a value indicates the factory default setting. | |

Disk Encryption

Note: This menu item appears only when a hard disk or an intelligent storage drive is installed.

| Menu item | Description |
|--|---|
| Hard Disk Intelligent Storage Drive | Show the encryption status of the hard disk or intelligent storage drive. |

Erase Temporary Data Files

| Menu item | Description |
|---|--|
| Stored in onboard memory Off* On | Delete all files stored on the printer memory. |
| Note: An asterisk (*) next to a value indicates the factory default setting. | |

Solutions LDAP Settings

| Menu item | Description |
|--|--|
| Follow LDAP Referrals Off* On | Search the different servers in the domain for the logged-in user account. |
| LDAP Certificate Verification Yes No* | Enable verification of LDAP certificates. |

Miscellaneous

| Menu item | Description |
|---|--|
| Protected Features Show* Hide | Show all the features that Function Access Control (FAC) protects regardless of the security permission that the user has. Note: Hide displays only FAC-protected features that the user has access. |
| Note: An asterisk (*) next to a value indicates the factory default setting. | |

| Menu item | Description |
|---|---|
| Print Permission Off* On | Let the user log in before printing. |
| Default Print Permission Login PIN* User Name/Password User Name | Set the default login for Print Permission. |
| Security Reset Jumper Enable "Guest" access* No Effect | Specify user access to the printer. Notes: <ul style="list-style-type: none"> • Enable "Guest" access allows for device recovery if the admin password is lost. If this issue occurs, then contact customer support. • No effect prevents using the security jumper for device recovery. • This menu item appears only when an actual security jumper hardware is installed. |
| Use Intelligent Storage Drive for User Data Off On* | Enable intelligent storage drive to store user data. Note: This menu item appears only when an intelligent storage drive is installed. |
| Minimum Password Length 0–32 (0*) | Specify the password length. |
| Enable Password/PIN Reveal Off* On | Show the password or personal identification number. |
| Note: An asterisk (*) next to a value indicates the factory default setting. | |

Reports

Menu Settings Page

| Menu item | Description |
|---------------------------|---|
| Menu Settings Page | Print a report that contains the printer menus. |

Device

| Menu item | Description |
|---------------------------|---|
| Device Information | Print a report that contains information about the printer. |
| Device Statistics | Print a report about printer usage and supply status. |
| Profiles List | Print a list of profiles that are stored in the printer. |

| Menu item | Description |
|---------------------|--|
| Asset Report | Print a diagnostic tool for print problems. Note: To avoid clipping the content, print the report on letter- or A4-size paper. |

Print

| Menu item | Description |
|---|---|
| Print Fonts PCL Fonts PS Fonts | Print samples and information about the fonts that are available in each printer language. |
| Print Demo Demo Page | Print a page that shows the printer capabilities and supported solutions. |
| Print Directory | Print the resources that are stored in the flash drive, hard disk, or intelligent storage drive (ISD). Note: This menu item appears only when a flash drive, a hard disk, or an ISD is installed. |

Shortcuts

| Menu item | Description |
|---------------------------------|---|
| All Shortcuts | Print a report that lists the shortcuts that are stored in the printer. |
| Fax Shortcuts | |
| Copy Shortcuts | |
| E-mail Shortcuts | |
| FTP Shortcuts | |
| Network Folder Shortcuts | |

Fax

Note: This menu appears only if Fax is configured, and Enable Job Log and Enable Call Log are set to On.

| Menu item | Description |
|---------------------|---|
| Fax Job Log | Print a report about the last 200 completed fax jobs. |
| Fax Call Log | Print a report about the last 100 attempted, received, and blocked calls. |

Network

| Menu item | Description |
|---------------------------------------|--|
| Network Setup Page | Print a page that shows the configured network and wireless settings on the printer. Note: This menu item appears only in network printers or printers connected to print servers. |
| Wi-Fi Direct Connected Clients | Print a page that shows the list of devices that are connected to the printer using Wi-Fi Direct. Note: This menu item appears only when Enable Wi-Fi Direct is set to On. |

Troubleshooting

| Menu item | Description |
|---------------------------------|---|
| Print Quality Test Pages | Print sample pages to identify and correct print quality defects. |
| Cleaning the Scanner | Print instructions on how to clean the scanner. |

Forms Merge

Note: This menu appears only when a hard disk or an intelligent storage drive is installed.

| Menu item | Description |
|---|--|
| Merge Mode Print* Data Capture Disabled | Specify the mode of operation for Forms Merge. |
| Data Capture Target Flash* | Set the target destination where the captured data is forwarded. Note: This menu item appears only when Merge Mode is set to Data Capture. |
| Print Port and Filter Settings Network Port On* Off | Enable Forms Merge to process all data that are sent to the network port. |
| Note: An asterisk (*) next to a value indicates the factory default setting. | |

| Menu item | Description |
|--|--|
| Print Port and Filter Settings Network Filter Disabled* NULL OFIS OFIS+NULL OFIS+AS400 AS400 PCL ZPL ZPLF | Specify the network filter for all data sent to the printer. |
| Print Port and Filter Settings USB Port On* Off | Enable Forms Merge to process all data that are sent to the USB port. |
| Print Port and Filter Settings USB Filter Disabled* NULL OFIS OFIS+NULL OFIS+AS400 AS400 PCL ZPL ZPLF | Specify the USB filter for all data sent to the printer. |
| Print Port and Filter Settings Local Port Timeout 1–100 (10*) | Specify the time-out value for Forms Merge jobs that are sent to the local port. |
| Miscellaneous Print All Forms | Print all form sets stored in the intelligent storage drive or hard disk of the printer. |
| Miscellaneous Error Page Print On* Off | Enable printing of an error page when an error is encountered in a Forms Merge job. |
| Note: An asterisk (*) next to a value indicates the factory default setting. | |

Printing the Menu Settings Page

From the home screen, touch **Settings > Reports > Menu Settings Page**.

Maintain the printer

Checking the status of parts and supplies

- 1 From the home screen, touch **Status/Supplies**.
- 2 Select the parts or supplies that you want to check.

Note: You can also access this setting by touching the top section of the home screen.

Configuring supply notifications

- 1 Open a web browser, and then type the printer IP address in the address field.

Notes:

- View the printer IP address on the printer home screen. The IP address appears as four sets of numbers separated by periods, such as 123.123.123.123.
- If you are using a proxy server, then temporarily disable it to load the web page correctly.

- 2 Click **Settings > Device > Notifications**.
- 3 From the Supplies menu, click **Custom Supply Notifications**.
- 4 Select a notification for each supply item.
- 5 Apply the changes.

Setting up e-mail alerts

Configure the printer to send e-mail alerts when supplies are low, when paper must be changed or added, or when there is a paper jam.

- 1 Open a web browser, and then type the printer IP address in the address field.

Notes:

- View the printer IP address on the printer home screen. The IP address appears as four sets of numbers separated by periods, such as 123.123.123.123.
- If you are using a proxy server, then temporarily disable it to load the web page correctly.

- 2 Click **Settings > Device > Notifications > E-mail Alert Setup**, and then configure the settings.
Note: For more information on SMTP settings, contact your e-mail provider.
- 3 Apply the changes.
- 4 Click **Setup E-mail Lists and Alerts**, and then configure the settings.
- 5 Apply the changes.

Viewing reports

- 1 From the home screen, touch **Settings** > **Reports**.
- 2 Select the report that you want to view.

Ordering parts and supplies

To order supplies, contact the place where you purchased the printer.

Note: All life estimates for printer supplies assume printing on letter- or A4-size plain paper.

Warning—Potential Damage: Failure to maintain optimum printer performance, or to replace parts and supplies, may cause damage to your printer.

Ordering a toner cartridge

Notes:

- The estimated cartridge yield is based on the ISO/IEC 19752 standard.
- Extremely low print coverage for extended periods of time may negatively affect actual yield.

To order a toner cartridge, contact the place where you purchased the printer.

Ordering an imaging unit

To order an imaging unit, contact the place where you purchased the printer.

Replacing parts and supplies

Replacing the toner cartridge

- 1 Open door A.

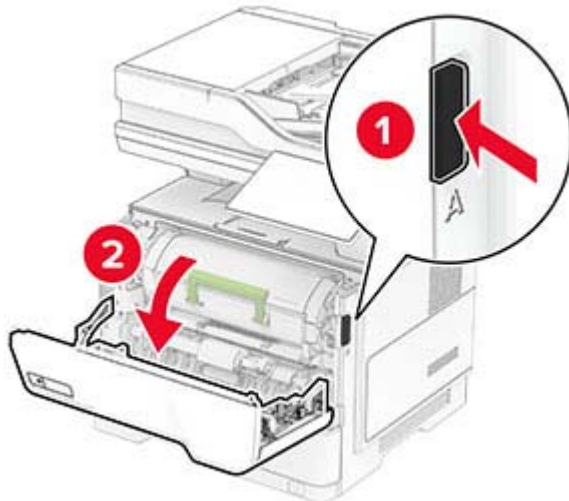

- 2 Remove the used toner cartridge.

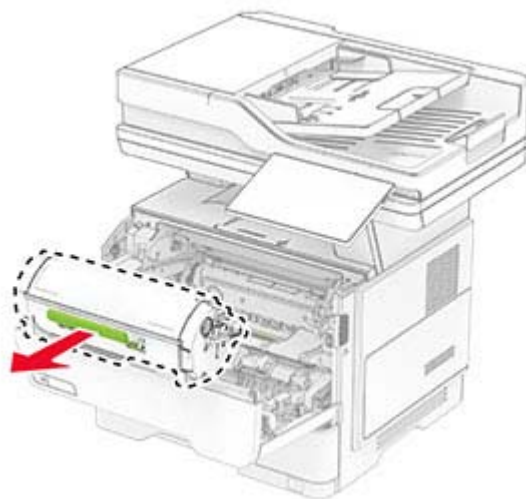

- 3 Unpack the new toner cartridge.

4 Shake the toner cartridge to redistribute the toner.

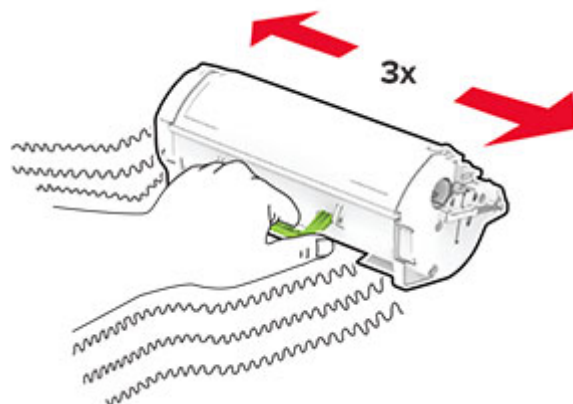

5 Insert the new toner cartridge.

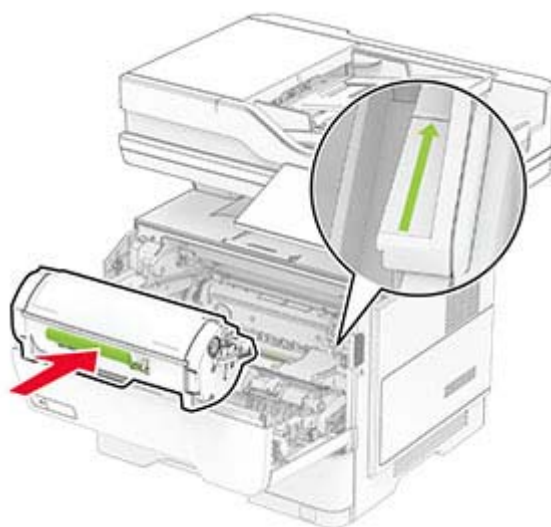

6 Close door A.

Replacing the imaging unit

1 Open door A.

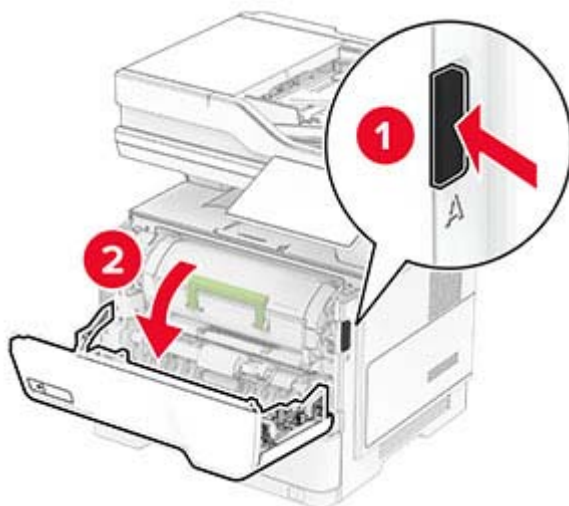

2 Remove the toner cartridge.

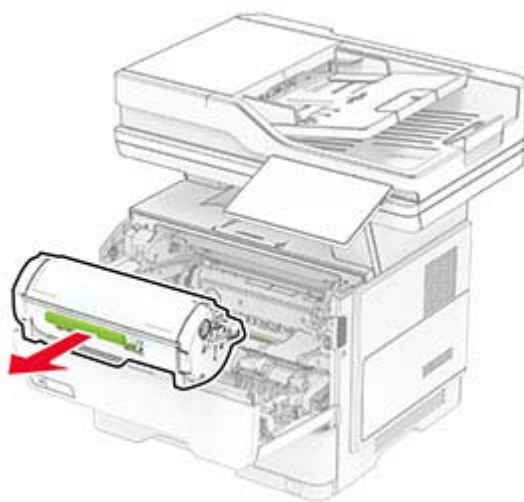

- 3 Remove the used imaging unit.

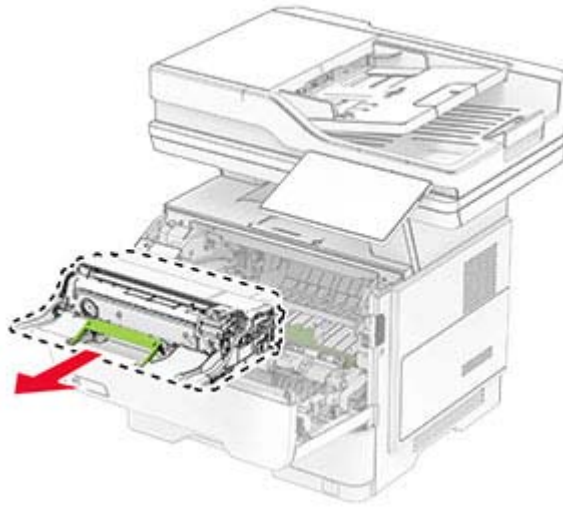

- 4 Unpack the new imaging unit.
- 5 Shake the imaging unit to redistribute the toner.

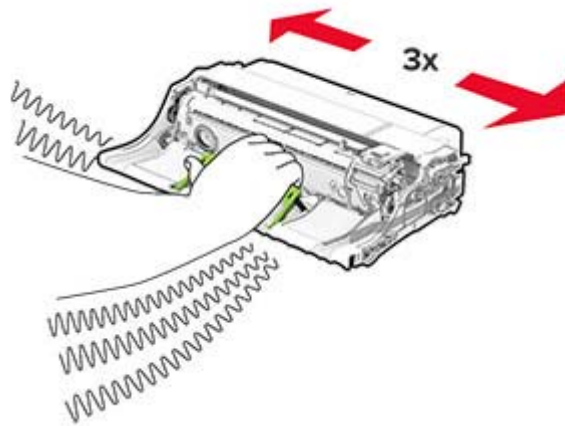

Warning—Potential Damage: Do not expose the imaging unit to direct light for more than 10 minutes. Extended exposure to light may cause print quality problems.

Warning—Potential Damage: Do not touch the photoconductor drum. Doing so may affect the quality of future print jobs.



6 Insert the new imaging unit.

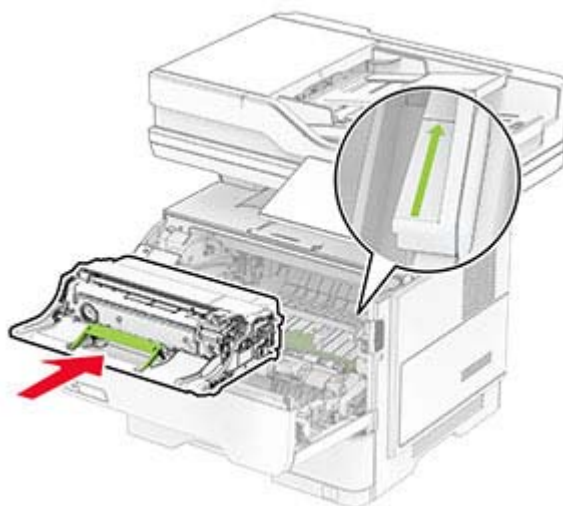

7 Insert the toner cartridge.

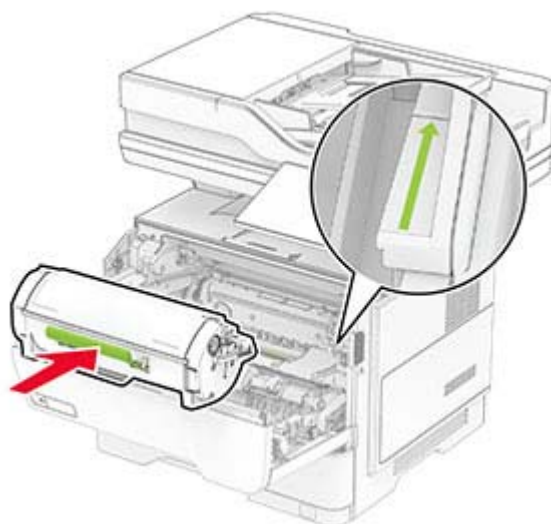

8 Close door A.

Replacing the staple refill

- 1 Open the convenience stapler access door.

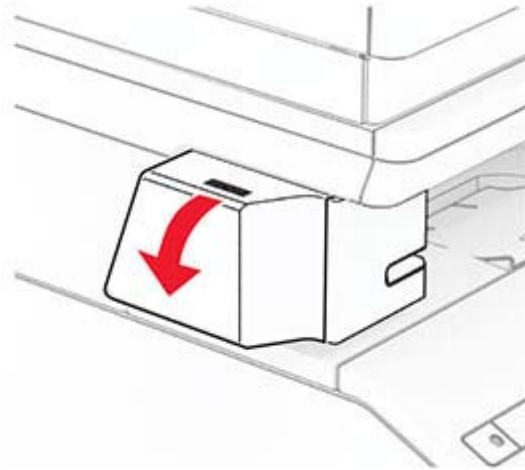

- 2 Remove the staple cartridge.

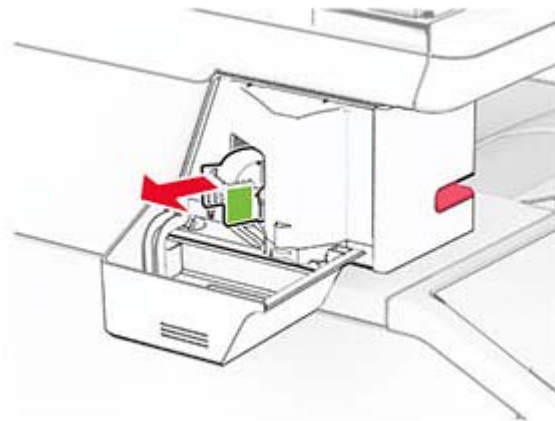

- 3 Remove the empty staple refill.



- 4 Insert the new staple refill until it clicks into place.

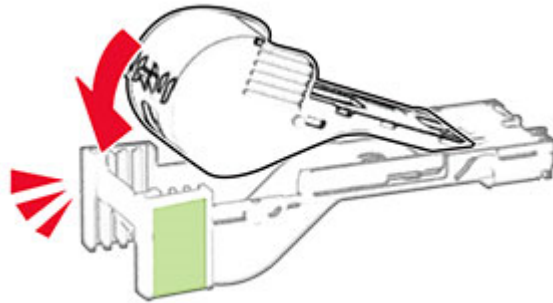

- 5 Insert the staple cartridge, and then close the convenience stapler access door.

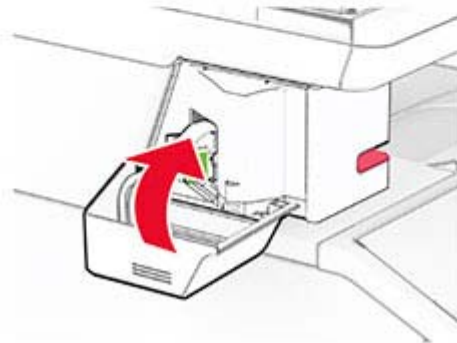
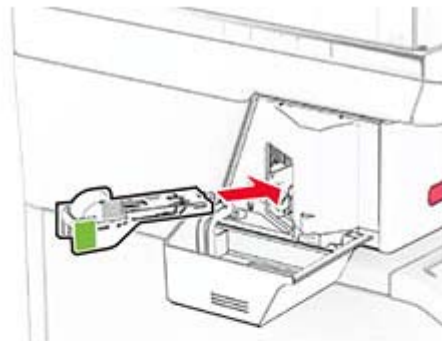

Note: Check the LED indicator status. The convenience stapler is ready to use when the blue light comes on.

Replacing the convenience stapler power supply

- 1 Turn off the printer.
- 2 Unplug the power cord from the electrical outlet, and then from the printer.
- 3 Unplug the power supply from the electrical outlet.

4 Remove the column cover and power supply cable.

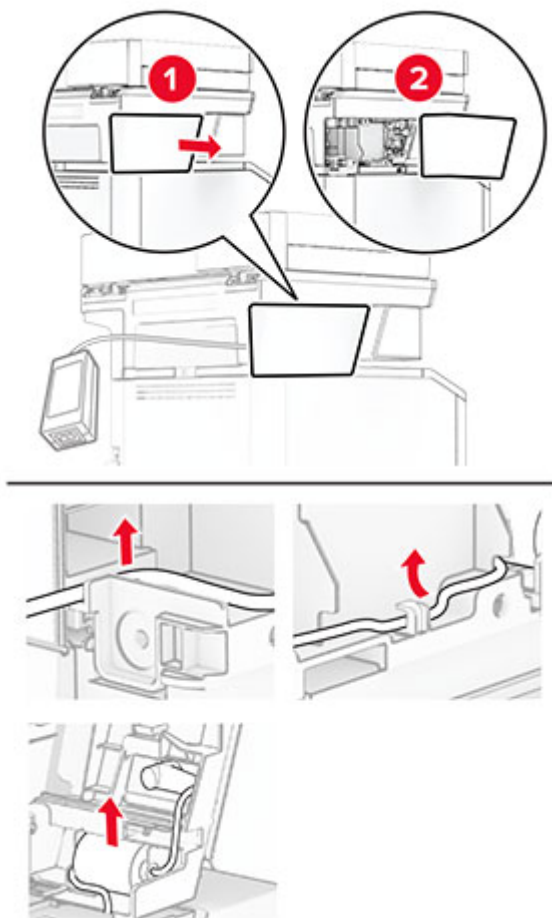

5 Remove the convenience stapler.

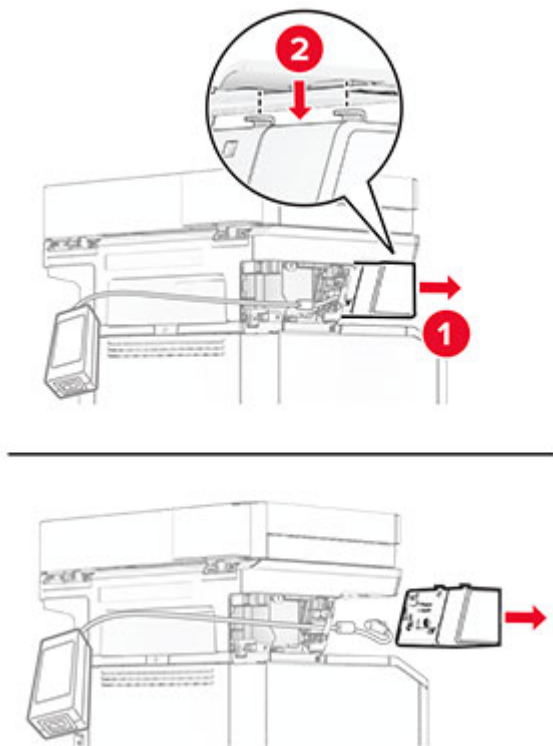

6 Remove the used power supply.

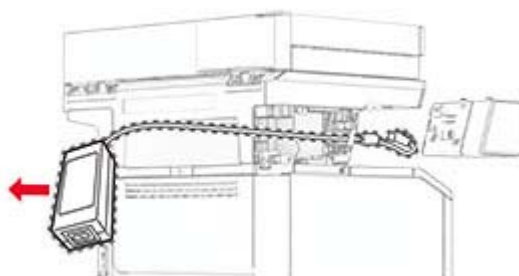

7 Unpack the new power supply.

8 Insert the new power supply through the printer, and then connect it to the convenience stapler.

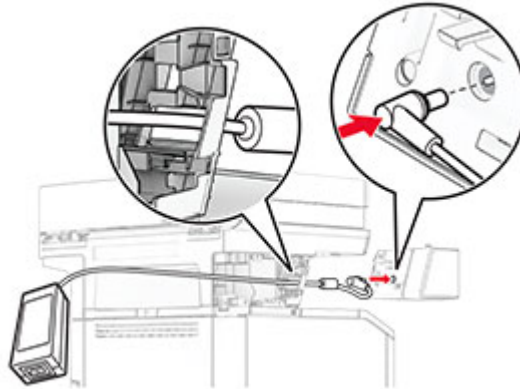
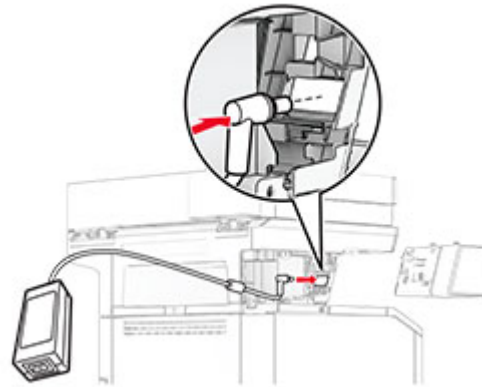

9 Install the convenience stapler.

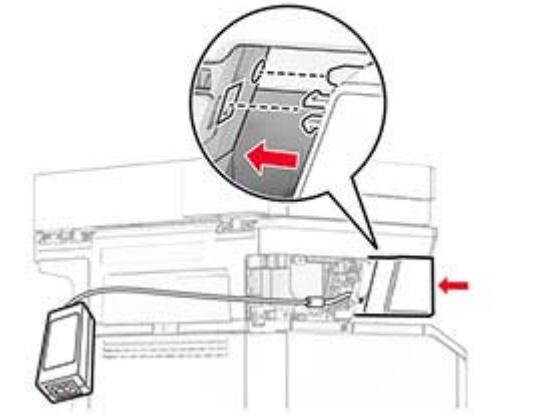
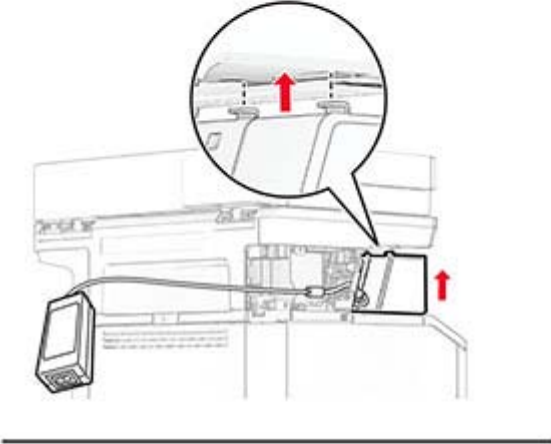
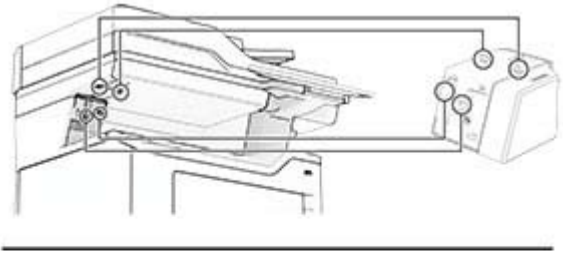

10 Position the power supply properly.

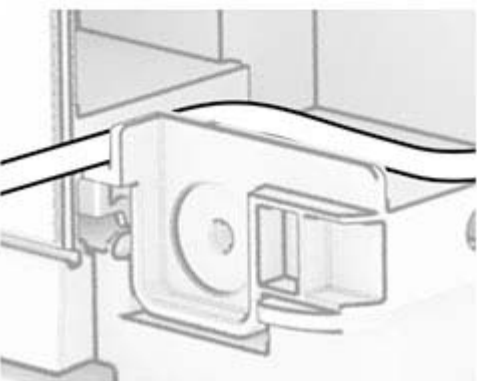
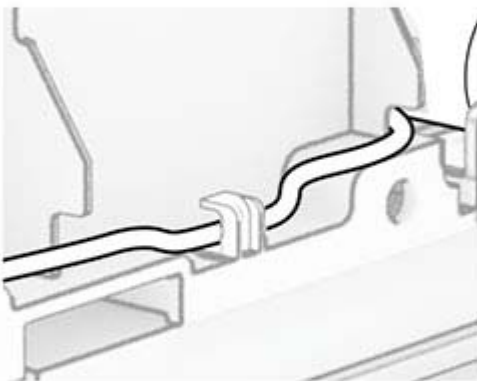
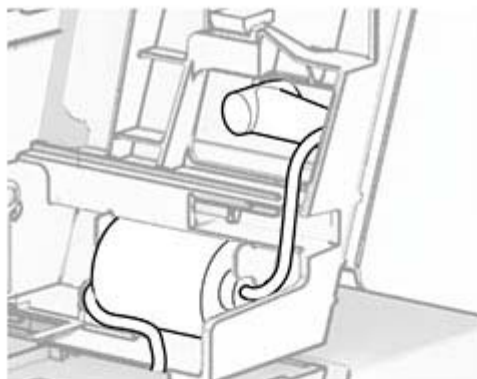

- 11 Attach the column cover.

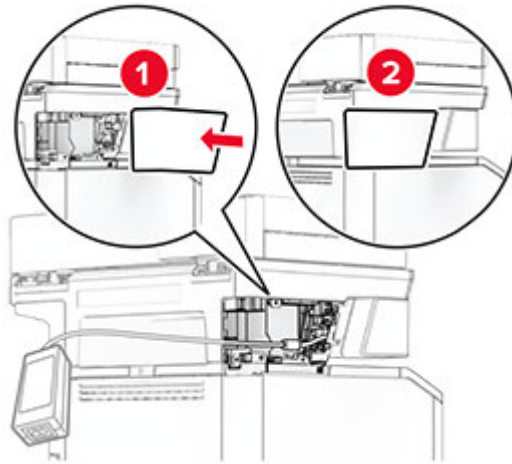

Note: Secure the power supply properly.



- 12 Connect one end of the stapler power cord to the power supply, and then the other end to the electrical outlet.
- 13 Connect one end of the printer power cord to the printer, and then the other end to the electrical outlet.
 **CAUTION—POTENTIAL INJURY:** To avoid the risk of fire or electrical shock, connect the power cord to an appropriately rated and properly grounded electrical outlet that is near the product and easily accessible.
- 14 Turn on the printer.

Replacing the pick tires

- 1 Turn off the printer.
- 2 Unplug the power cord from the electrical outlet, and then from the printer.

3 Remove the tray.



4 Remove the used pick tires.

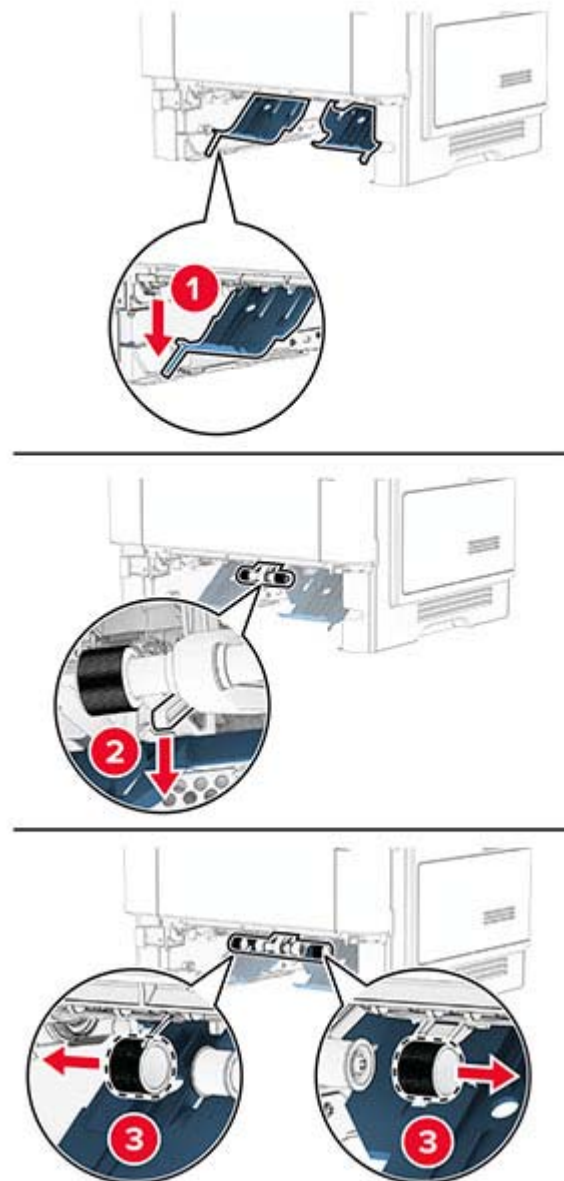

- 5 Unpack the new pick tires.
- 6 Insert the new pick tires.

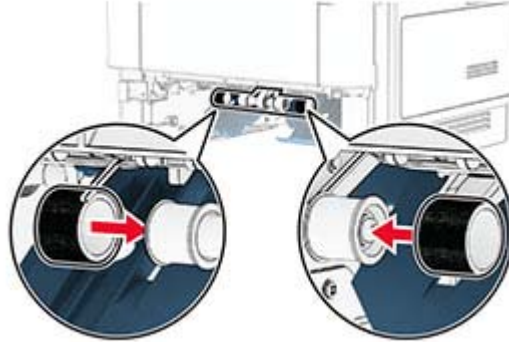

- 7 Insert the tray.
- 8 Connect the power cord to the printer, and then to the electrical outlet.

⚠ CAUTION—POTENTIAL INJURY: To avoid the risk of fire or electrical shock, connect the power cord to an appropriately rated and properly grounded electrical outlet that is near the product and easily accessible.

- 9 Turn on the printer.

Replacing the scanner glass pad

- 1 Open the scanner cover.

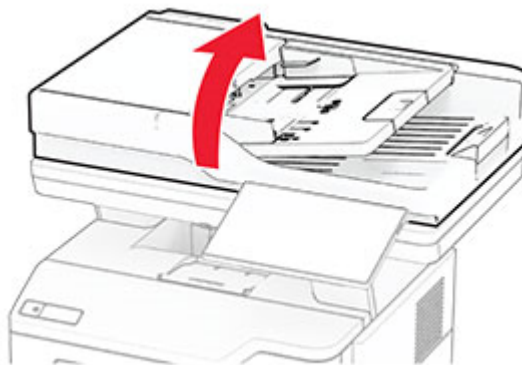

2 Remove the used scanner glass pad.

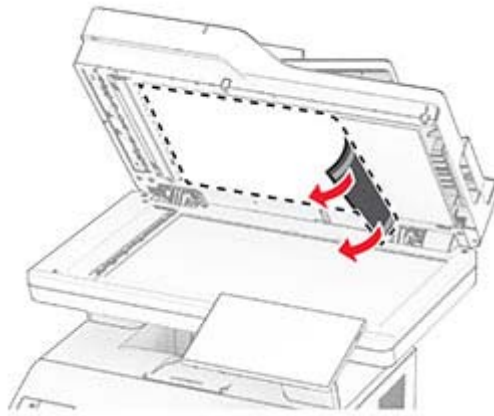

3 Unpack the new scanner glass pad.

4 Align the new scanner glass pad to the scanner glass.

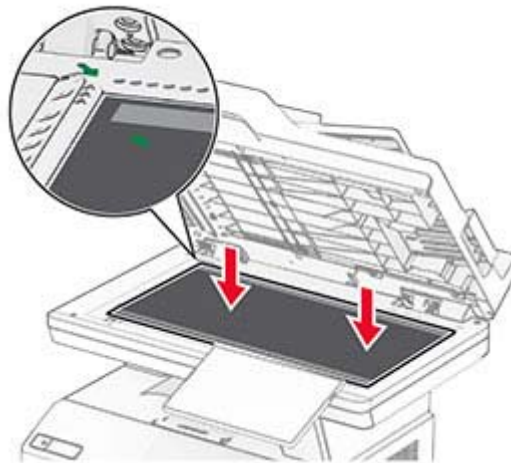

5 Close the scanner cover to attach the new scanner glass pad.

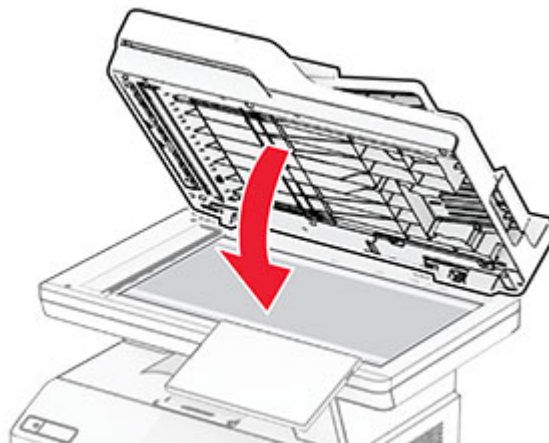

- 6 Open the scanner cover.
- 7 Apply pressure to the scanner glass pad to secure it.

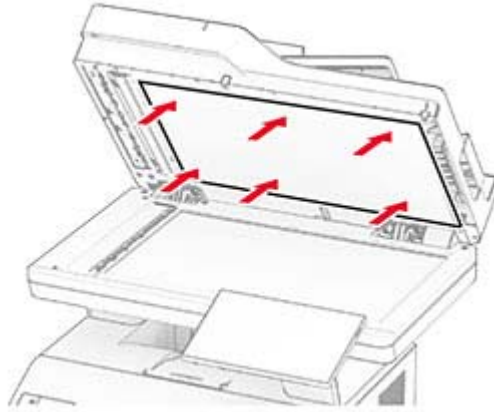

- 8 Close the scanner cover.

Replacing the ADF rollers

- 1 Open door C.

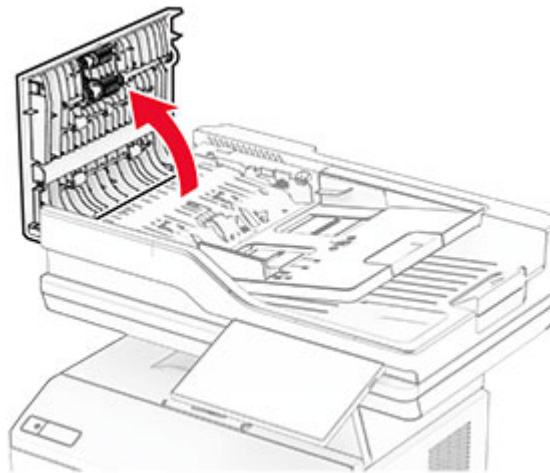

2 Remove the used ADF pick roller.

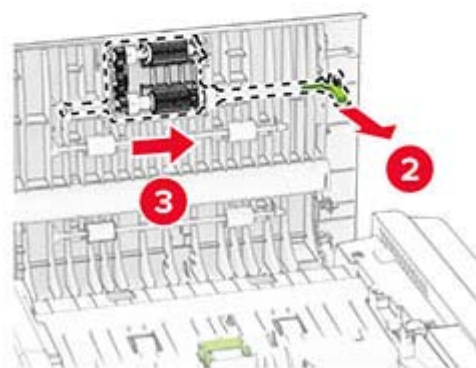
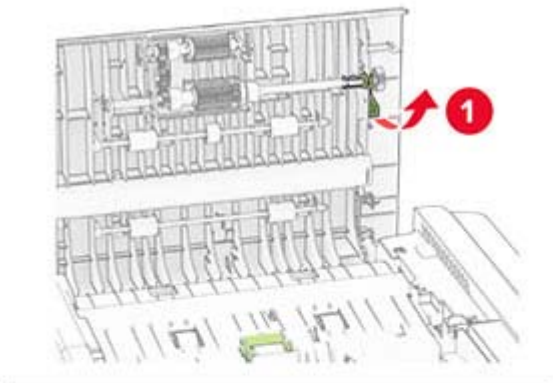

3 Remove the used ADF separator roller.



4 Unpack the new ADF pick roller and ADF separator roller.

5 Insert the new ADF separator roller until it *clicks* into place.

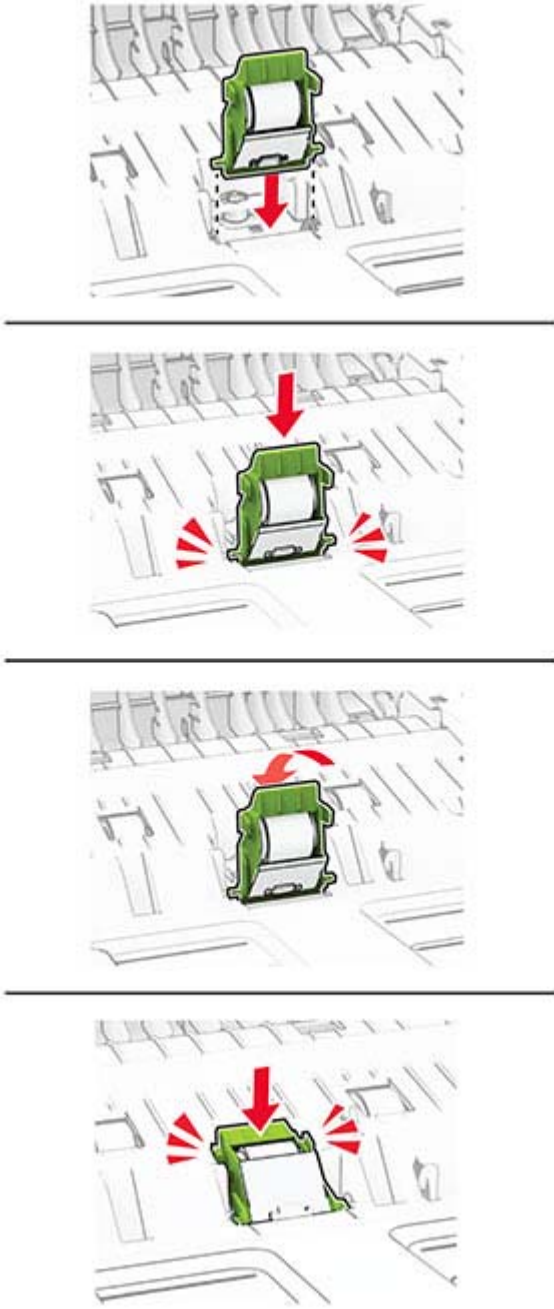

6 Insert the new ADF pick roller until it *clicks* into place.

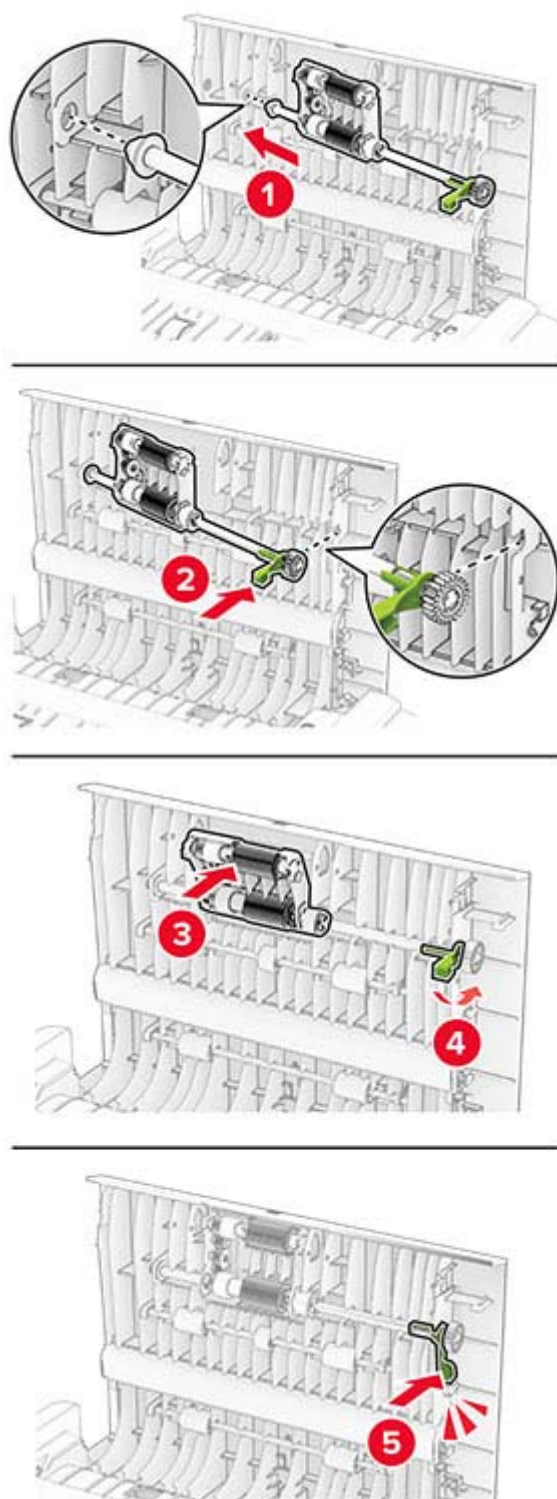

7 Close door C.

Resetting the supply usage counters

- 1 From the home screen, touch **Settings > Device > Maintenance > Configuration Menu > Supply Usage And Counters**.
- 2 Select the counter that you want to reset.

Warning—Potential Damage: Supplies and parts without use-and-return program agreement terms may be reset and remanufactured. However, the manufacturer's warranty does not cover any damage caused by non-genuine supplies or parts. Resetting counters on the supply or part without proper remanufacturing can cause damage to your printer. After resetting the supply or part counter, your printer may display an error indicating the presence of the reset item.

Cleaning printer parts

Cleaning the printer

 **CAUTION—SHOCK HAZARD:** To avoid the risk of electrical shock when cleaning the exterior of the printer, unplug the power cord from the electrical outlet and disconnect all cables from the printer before proceeding.

Notes:

- Perform this task after every few months.
- Damage to the printer caused by improper handling is not covered by the printer warranty.

- 1 Turn off the printer, and then unplug the power cord from the electrical outlet.
- 2 Remove paper from the standard bin and multipurpose feeder.
- 3 Remove any dust, lint, and pieces of paper around the printer using a soft brush or vacuum.
- 4 Wipe the outside of the printer with a damp, soft, lint-free cloth.

Notes:

- Do not use household cleaners or detergents, as they may damage the finish of the printer.
- Make sure that all areas of the printer are dry after cleaning.

- 5 Connect the power cord to the electrical outlet, and then turn on the printer.

 **CAUTION—POTENTIAL INJURY:** To avoid the risk of fire or electrical shock, connect the power cord to an appropriately rated and properly grounded electrical outlet that is near the product and easily accessible.

Cleaning the touch screen

 **CAUTION—SHOCK HAZARD:** To avoid the risk of electric shock when cleaning the exterior of the printer, unplug the power cord from the electrical outlet and disconnect all cables from the printer before proceeding.

- 1 Turn off the printer, and then unplug the power cord from the electrical outlet.
- 2 Using a damp, soft, lint-free cloth, wipe the touch screen.

Notes:

- Do not use household cleaners or detergents, as they may damage the touch screen.
- Make sure that the touch screen is dry after cleaning.

3 Connect the power cord to the electrical outlet, and then turn on the printer.

⚠ CAUTION—POTENTIAL INJURY: To avoid the risk of fire or electrical shock, connect the power cord to an appropriately rated and properly grounded electrical outlet that is near the product and easily accessible.

Cleaning the scanner

1 Open the scanner cover.

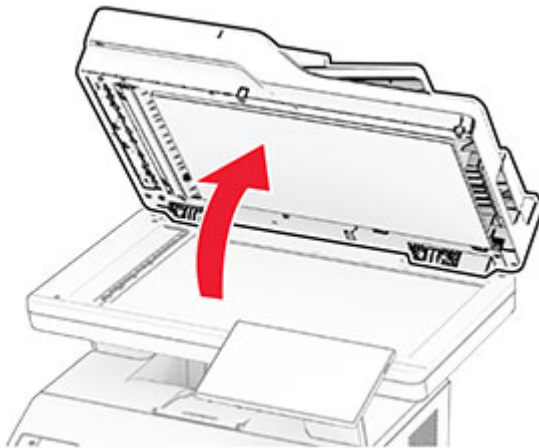

2 Using a damp, soft, lint-free cloth, wipe the following areas:

- ADF glass pad

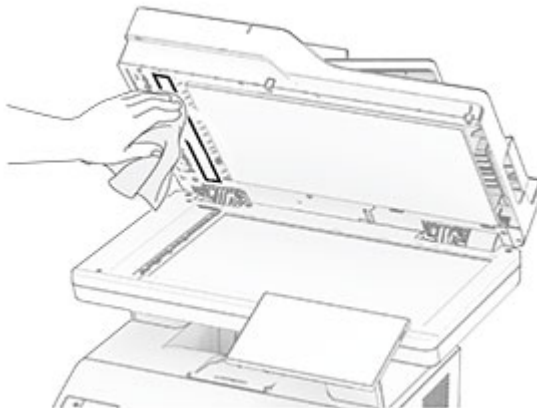

- Scanner glass pad



- ADF glass

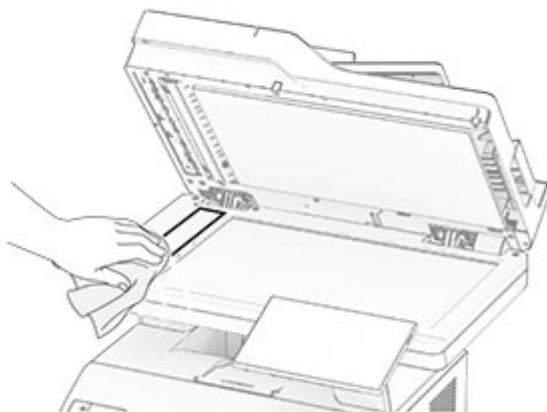

- Scanner glass



3 Close the scanner cover.

4 Open door C.

5 Using a damp, soft, lint-free cloth, wipe the following areas:

- ADF glass pad in door C

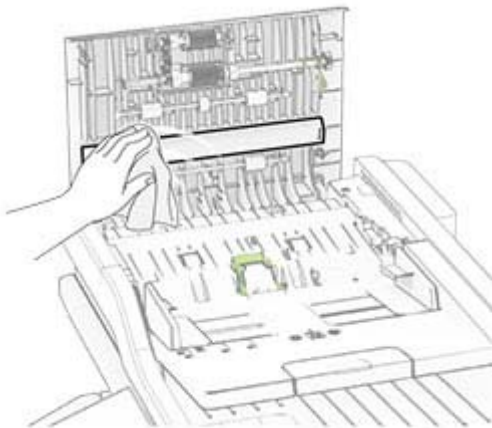

- ADF glass in door C

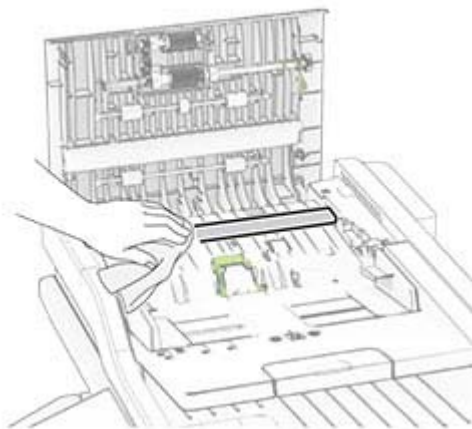

6 Close door C.

Cleaning the ADF rollers

- 1 Open door C.

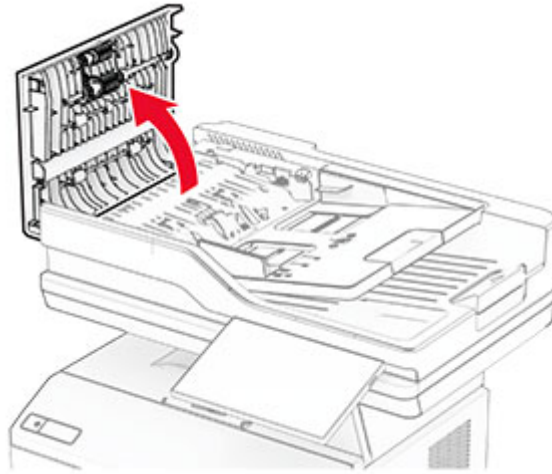

- 2 Remove the ADF pick roller.

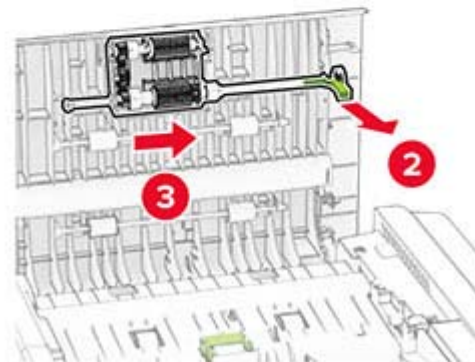
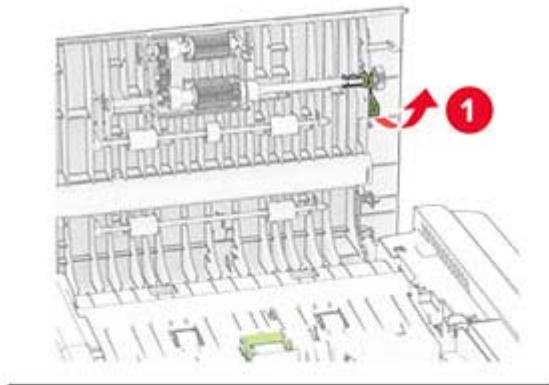

- 3** Remove the ADF separator roller.

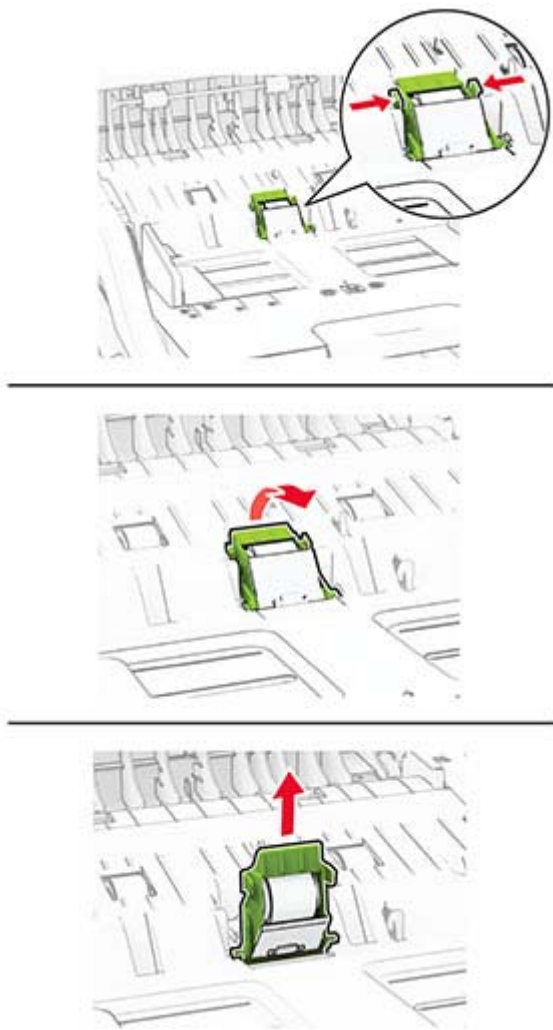

- 4** Apply isopropyl alcohol to a soft, lint-free cloth, and then wipe the ADF pick roller and ADF separator roller.

5 Insert the ADF separator roller until it *clicks* into place.

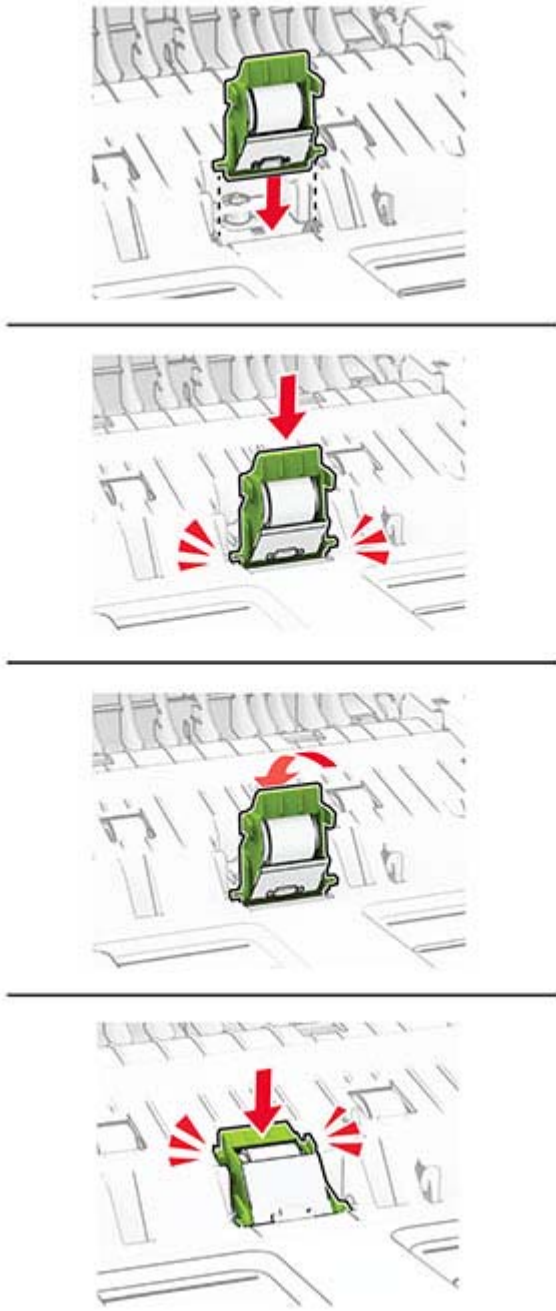

6 Insert the ADF pick roller until it *clicks* into place.

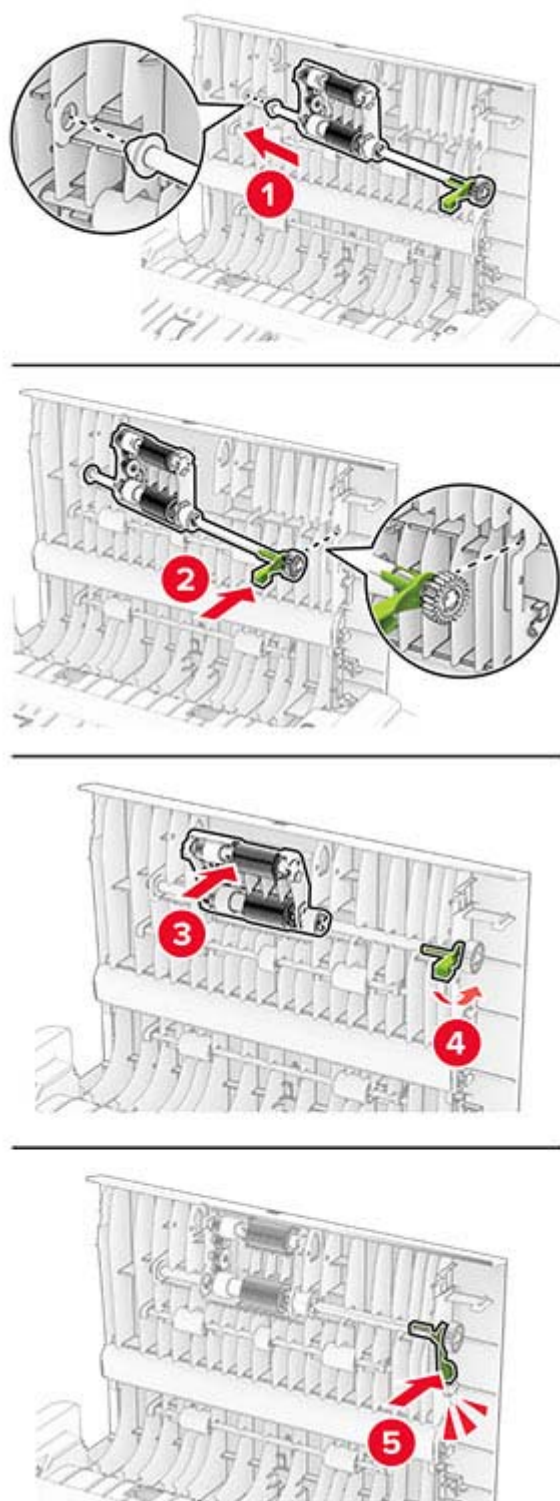

7 Close door C.

Saving energy and paper

Configuring the power save mode settings

Sleep mode

- 1 From the home screen, touch **Settings > Device > Power Management > Timeouts > Sleep Mode**.
- 2 Specify the amount of time that the printer stays idle before it enters Sleep Mode.

Hibernate mode

- 1 From the home screen, touch **Settings > Device > Power Management > Timeouts > Hibernate Timeout**.
- 2 Select the amount of time that the printer stays idle before it enters Hibernate mode.

Notes:

- For Hibernate Timeout to work, set Hibernate Timeout on Connection to Hibernate.
- The Embedded Web Server is disabled when the printer is in Hibernate mode.

Adjusting the brightness of the display

- 1 From the home screen, touch **Settings > Device > Preferences**.
- 2 In the Screen Brightness menu, adjust the setting.

Conserving supplies

- Print on both sides of the paper.
Note: Two-sided printing is the default setting in the print driver.
- Print multiple pages on a single sheet of paper.
- Use the preview feature to see how the document looks like before printing it.
- Print one copy of the document to check its content and format for accuracy.

Moving the printer to another location

 **CAUTION—POTENTIAL INJURY:** If the printer weight is greater than 20 kg (44 lb), then it may require two or more people to lift it safely.

 **CAUTION—POTENTIAL INJURY:** To avoid the risk of fire or electrical shock, use only the power cord provided with this product or the manufacturer's authorized replacement.

 **CAUTION—POTENTIAL INJURY:** When moving the printer, follow these guidelines to avoid personal injury or printer damage:

- Make sure that all doors and trays are closed.
- Turn off the printer, and then unplug the power cord from the electrical outlet.
- Disconnect all cords and cables from the printer.

- If the printer has separate floor-standing optional trays or output options attached to it, then disconnect them before moving the printer.
- If the printer has a caster base, then carefully roll it to the new location. Use caution when passing over thresholds and breaks in flooring.
- If the printer does not have a caster base but is configured with optional trays or output options, then remove the output options and lift the printer off the trays. Do not try to lift the printer and any options at the same time.
- Always use the handholds on the printer to lift it.
- Any cart used to move the printer must have a surface able to support the full footprint of the printer.
- Any cart used to move the hardware options must have a surface able to support the dimensions of the options.
- Keep the printer in an upright position.
- Avoid severe jarring movements.
- Make sure that your fingers are not under the printer when you set it down.
- Make sure that there is adequate clearance around the printer.

Note: Damage to the printer caused by improper moving is not covered by the printer warranty.

Shipping the printer

When shipping the printer, use the original packaging or contact the place where you purchased the printer.

Troubleshoot a problem

Print quality problems

Find the image that resembles the print quality problem you are having, and then click the link below it to read problem-solving steps.

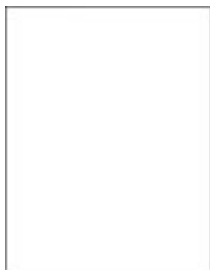

[“Blank or white pages” on page 211](#)



[“Dark print” on page 212](#)



[“Fine lines are not printed correctly” on page 214](#)



[“Folded or wrinkled paper” on page 215](#)



[“Gray background” on page 216](#)



[“Horizontal light bands” on page 226](#)



[“Incorrect margins” on page 218](#)



[“Light print” on page 218](#)



[“Mottled print and dots” on page 220](#)



[“Paper curl” on page 221](#)



[“Print crooked or skewed” on page 223](#)



[“Repeating defects” on page 232](#)



[“Solid black pages” on page 223](#)



[“Text or images cut off” on page 224](#)



[“Toner easily rubs off” on page 225](#)



[“Vertical dark bands” on page 228](#)



[“Vertical dark lines or streaks” on page 230](#)

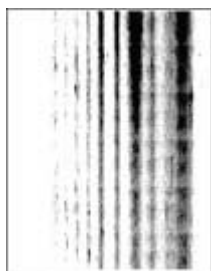

[“Vertical dark streaks with print missing” on page 231](#)



[“Vertical light bands” on page 227](#)



[“Vertical white lines” on page 228](#)

Printing problems

Print quality is poor

Blank or white pages

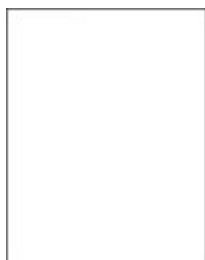

Note: Before solving the problem, print the Print Quality Test Pages. From the home screen, touch **Settings** > **Troubleshooting** > **Print Quality Test Pages**.

| Action | Yes | No |
|---|---------------|------------------------|
| <p>Step 1</p> <p>a Check if the printer is using a genuine and supported toner cartridge.</p> <p>Note: If the cartridge is not supported, then install a supported one.</p> <p>b Print the document.</p> <p>Is the printer printing blank or white pages?</p> | Go to step 2. | The problem is solved. |

| Action | Yes | No |
|---|---|-------------------------------|
| <p>Step 2</p> <p>a Remove any packing material that is left on the imaging unit.</p> <p>1 Remove the toner cartridge, and then remove the imaging unit.</p> <p>Warning—Potential Damage: Do not expose the imaging unit to direct light for more than 10 minutes. Extended exposure to light may cause print quality problems.</p> <p>Warning—Potential Damage: Do not touch the photoconductor drum under the imaging unit. Doing so may affect the quality of future print jobs.</p> <p>2 Check the imaging unit for signs of damage, and replace if necessary.</p> <p>Note: Make sure that the photoconductor drum contact is not bent or out of place.</p> <p>3 Firmly shake the imaging unit to redistribute the toner.</p> <p>4 Insert the imaging unit, and then insert the toner cartridge.</p> <p>b Print the document.</p> <p>Is the printer printing blank or white pages?</p> | <p>Go to step 3.</p> | <p>The problem is solved.</p> |
| <p>Step 3</p> <p>Check the status of the toner cartridge, and replace if necessary.</p> <p>a From the home screen, touch Status/Supplies > Supplies.</p> <p>b Print the document.</p> <p>Is the printer printing blank or white pages?</p> | <p>Contact your dealer.</p> | <p>The problem is solved.</p> |

Dark print



Note: Before solving the problem, print the Print Quality Test Pages. From the home screen, touch **Settings > Troubleshooting > Print Quality Test Pages**.

| Action | Yes | No |
|--|---------------|------------------------|
| <p>Step 1</p> <p>a Check if the printer is using a genuine and supported toner cartridge.</p> <p>Note: If the cartridge is not supported, then install a supported one.</p> <p>b Print the document.</p> <p>Is the print dark?</p> | Go to step 2. | The problem is solved. |
| <p>Step 2</p> <p>a Turn off the printer, wait for about 10 seconds, and then turn on the printer.</p> <p>b Reduce toner darkness. From the home screen, touch Settings > Print > Quality > Toner Darkness.</p> <p>c Print the document.</p> <p>Is the print dark?</p> | Go to step 3. | The problem is solved. |
| <p>Step 3</p> <p>a Depending on your operating system, specify the paper type from the Printing Preferences or Print dialog.</p> <p>Notes:</p> <ul style="list-style-type: none"> • Make sure that the setting matches the paper loaded. • You can also change the setting on the printer control panel. From the home screen, touch Settings > Paper > Tray Configuration > Paper Size/Type. <p>b Print the document.</p> <p>Is the print dark?</p> | Go to step 4. | The problem is solved. |
| <p>Step 4</p> <p>Check if the paper has texture or rough finishes.</p> <p>Are you printing on textured or rough paper?</p> | Go to step 5. | Go to step 6. |
| <p>Step 5</p> <p>a Replace textured paper with plain paper.</p> <p>b Print the document.</p> <p>Is the print dark?</p> | Go to step 6. | The problem is solved. |

| Action | Yes | No |
|---|---------------------------------------|------------------------|
| <p>Step 6</p> <p>a Load paper from a fresh package.</p> <p>Note: Paper absorbs moisture due to high humidity. Store paper in its original wrapper until you are ready to use it.</p> <p>b Print the document.</p> <p>Is the print dark?</p> | Go to step 7. | The problem is solved. |
| <p>Step 7</p> <p>a Remove, and then insert the imaging unit.</p> <p>Warning—Potential Damage: Do not expose the imaging unit to direct light for more than 10 minutes. Extended exposure to light may cause print quality problems.</p> <p>Warning—Potential Damage: Do not touch the photoconductor drum under the imaging unit. Doing so may affect the quality of future print jobs.</p> <p>b Print the document.</p> <p>Is the print dark?</p> | Go to step 8. | The problem is solved. |
| <p>Step 8</p> <p>a Replace the imaging unit.</p> <p>b Print the document.</p> <p>Is the print dark?</p> | Contact your dealer . | The problem is solved. |

Fine lines are not printed correctly



Note: Before solving the problem, print the Print Quality Test Pages. From the home screen, touch **Settings** > **Troubleshooting** > **Print Quality Test Pages**.

| Action | Yes | No |
|--|------------------------|---------------------------------------|
| <p>Step 1</p> <p>a Check if the printer is using a genuine and supported toner cartridge.</p> <p>Note: If the cartridge is not supported, then install a supported one.</p> <p>b Print the document.</p> <p>Are fine lines printed correctly?</p> | The problem is solved. | Go to step 2. |
| <p>Step 2</p> <p>a Adjust the print quality settings.</p> <p>1 From the home screen, touch Settings > Print > Quality > Pixel Boost > Fonts.</p> <p>2 Adjust Toner Darkness to 7. From the home screen, touch Settings > Print > Quality > Toner Darkness.</p> <p>b Print the document.</p> <p>Are fine lines printed correctly?</p> | The problem is solved. | Contact your dealer . |

Folded or wrinkled paper



Note: Before solving the problem, print the Print Quality Test Pages. From the home screen, touch **Settings > Troubleshooting > Print Quality Test Pages**.

| Action | Yes | No |
|--|---------------|------------------------|
| <p>Step 1</p> <p>a Check if the printer is using a genuine and supported toner cartridge.</p> <p>Note: If the cartridge is not supported, then install a supported one.</p> <p>b Print the document.</p> <p>Is the paper folded or wrinkled?</p> | Go to step 2. | The problem is solved. |

| Action | Yes | No |
|--|---------------------------------------|------------------------|
| <p>Step 2</p> <p>a Load paper from a fresh package.</p> <p>Note: Paper absorbs moisture due to high humidity. Store paper in its original wrapper until you are ready to use it.</p> <p>b Print the document.</p> <p>Is the paper folded or wrinkled?</p> | Go to step 3. | The problem is solved. |
| <p>Step 3</p> <p>a Depending on your operating system, specify the paper type from the Printing Preferences or Print dialog.</p> <p>Notes:</p> <ul style="list-style-type: none"> • Make sure that the setting matches the paper loaded. • You can also change the setting from the printer control panel. From the home screen, touch Settings > Paper > Tray Configuration > Paper Size/Type. <p>b Print the document.</p> <p>Is the paper folded or wrinkled?</p> | Contact your dealer . | The problem is solved. |

Gray background



Note: Before solving the problem, print the Print Quality Test Pages. From the home screen, touch **Settings > Troubleshooting > Print Quality Test Pages**.

| Action | Yes | No |
|--|---------------|------------------------|
| <p>Step 1</p> <p>a Turn off the printer, wait for 10 seconds, and then turn on the printer.</p> <p>b Decrease toner darkness.</p> <p>From the home screen, touch Settings > Print > Quality > Toner Darkness.</p> <p>c Print the document.</p> <p>Does gray background appear on prints?</p> | Go to step 2. | The problem is solved. |

| Action | Yes | No |
|--|---|-------------------------------|
| <p>Step 2</p> <p>a Check if the printer is using a genuine and supported toner cartridge.</p> <p>Note: If the cartridge is not supported, then install a supported one.</p> <p>b Print the document.</p> <p>Does gray background appear on prints?</p> | <p>Go to step 3.</p> | <p>The problem is solved.</p> |
| <p>Step 3</p> <p>a Depending on your operating system, specify the paper type from the Printing Preferences or Print dialog.</p> <p>Notes:</p> <ul style="list-style-type: none"> • Make sure that the setting matches the paper loaded. • You can also change the setting from the printer control panel. From the home screen, touch Settings > Paper > Tray Configuration > Paper Size/Type. <p>b Print the document.</p> <p>Does gray background appear on prints?</p> | <p>Go to step 4.</p> | <p>The problem is solved.</p> |
| <p>Step 4</p> <p>a Remove, and then insert the imaging unit.</p> <p>Warning—Potential Damage: Do not expose the imaging unit to direct light. Extended exposure to light may cause print quality problems.</p> <p>Warning—Potential Damage: Do not touch the photoconductor drum. Doing so may affect the quality of future print jobs.</p> <p>b Print the document.</p> <p>Does gray background appear on prints?</p> | <p>Go to step 5.</p> | <p>The problem is solved.</p> |
| <p>Step 5</p> <p>a Update the printer firmware. For more information, see “Updating firmware” on page 46.</p> <p>b Print the document.</p> <p>Does gray background appear on prints?</p> | <p>Go to step 6.</p> | <p>The problem is solved.</p> |
| <p>Step 6</p> <p>a Replace the imaging unit.</p> <p>b Print the document.</p> <p>Does gray background appear on prints?</p> | <p>Contact your dealer.</p> | <p>The problem is solved.</p> |

Incorrect margins



Note: Before solving the problem, print the Print Quality Test Pages. From the home screen, touch **Settings** > **Troubleshooting** > **Print Quality Test Pages**.

| Action | Yes | No |
|---|-------------------------------|---|
| <p>Step 1</p> <p>a Adjust the paper guides in the tray to the correct position for the paper loaded.</p> <p>b Print the document.</p> <p>Are the margins correct?</p> | <p>The problem is solved.</p> | <p>Go to step 2.</p> |
| <p>Step 2</p> <p>a Depending on your operating system, specify the paper size from the Printing Preferences or Print dialog.</p> <p>Notes:</p> <ul style="list-style-type: none"> • Make sure that the setting matches the paper loaded. • You can also change the setting on the printer control panel. From the home screen, touch Settings > Paper > Tray Configuration > Paper Size/Type. <p>b Print the document.</p> <p>Are the margins correct?</p> | <p>The problem is solved.</p> | <p>Contact your dealer.</p> |

Light print



Note: Before solving the problem, print the Print Quality Test Pages. From the home screen, touch **Settings** > **Troubleshooting** > **Print Quality Test Pages**.

| Action | Yes | No |
|---|----------------------|-------------------------------|
| <p>Step 1</p> <p>a Check if the printer is using a genuine and supported toner cartridge.</p> <p>Note: If the cartridge is not supported, then install a supported one.</p> <p>b Print the document.</p> <p>Is the print light?</p> | <p>Go to step 2.</p> | <p>The problem is solved.</p> |
| <p>Step 2</p> <p>a Turn off the printer, wait for about 10 seconds, and then turn on the printer.</p> <p>b Increase toner darkness. From the home screen, touch Settings > Print > Quality > Toner Darkness.</p> <p>c Print the document.</p> <p>Is the print light?</p> | <p>Go to step 3.</p> | <p>The problem is solved.</p> |
| <p>Step 3</p> <p>a Depending on your operating system, specify the paper type from the Printing Preferences or Print dialog.</p> <p>Notes:</p> <ul style="list-style-type: none"> • Make sure that the setting matches the paper loaded. • You can also change the setting on the printer control panel. From the home screen, touch Settings > Paper > Tray Configuration > Paper Size/Type. <p>b Print the document.</p> <p>Is the print light?</p> | <p>Go to step 4.</p> | <p>The problem is solved.</p> |
| <p>Step 4</p> <p>a Depending on your operating system, specify the print resolution from the Printing Preferences or Print dialog.</p> <p>b Set the resolution to 600 dpi.</p> <p>c Print the document.</p> <p>Is the print light?</p> | <p>Go to step 5.</p> | <p>The problem is solved.</p> |

| Action | Yes | No |
|--|---------------------------------------|---------------------------------------|
| <p>Step 5</p> <p>a Remove the imaging unit.</p> <p>Warning—Potential Damage: Do not expose the imaging unit to direct light. Extended exposure to light can cause print quality problems.</p> <p>Warning—Potential Damage: Do not touch the photoconductor drum. Doing so may affect the quality of future print jobs.</p> <p>b Firmly shake the imaging unit to redistribute the toner.</p> <p>c Insert the imaging unit.</p> <p>d Turn off the printer, wait for 10 seconds, and then turn on the printer.</p> <p>e Print the document.</p> <p>Is the print light?</p> | Go to step 6. | The problem is solved. |
| <p>Step 6</p> <p>a Check the status of the toner cartridge.</p> <p>From the home screen, touch Settings > Reports > Device > Device Statistics.</p> <p>b From the Supply Information section of the pages printed, check the status of the toner cartridge.</p> <p>Is the toner cartridge near end of life?</p> | Go to step 7. | Contact your dealer . |
| <p>Step 7</p> <p>a Replace the toner cartridge.</p> <p>b Print the document.</p> <p>Is the print light?</p> | Contact your dealer . | The problem is solved. |

Mottled print and dots



Note: Before solving the problem, print the Print Quality Test Pages. From the home screen, touch **Settings > Troubleshooting > Print Quality Test Pages**.

| Action | Yes | No |
|---|---------------------------------------|---------------------------------------|
| <p>Step 1</p> <p>a Check if the printer is using a genuine and supported toner cartridge.</p> <p>Note: If the cartridge is not supported, then install a supported one.</p> <p>b Print the document.</p> <p>Is the print mottled?</p> | Go to step 2. | The problem is solved. |
| <p>Step 2</p> <p>Check the printer for leaked toner contamination.</p> <p>Is the printer free of leaked toner?</p> | Go to step 4. | Go to step 3. |
| <p>Step 3</p> <p>a Replace the toner cartridge.</p> <p>b Print the document.</p> <p>Is the print mottled?</p> | Go to step 4. | The problem is solved. |
| <p>Step 4</p> <p>Check the status of the imaging unit.</p> <p>From the home screen, touch Status/Supplies > Supplies.</p> <p>Is the imaging unit near end of life?</p> | Go to step 5. | Contact your dealer . |
| <p>Step 5</p> <p>a Replace the imaging unit.</p> <p>b Print the document.</p> <p>Is the print mottled?</p> | Contact your dealer . | The problem is solved. |

Paper curl



| Action | Yes | No |
|--|---------------------------------------|------------------------|
| <p>Step 1</p> <p>a Check if the printer is using a genuine and supported toner cartridge.</p> <p>Note: If the cartridge is not supported, then install a supported one.</p> <p>b Print the document.</p> <p>Is the paper curled?</p> | Go to step 2. | The problem is solved. |
| <p>Step 2</p> <p>a Adjust the guides in the tray to the correct position for the paper loaded.</p> <p>b Print the document.</p> <p>Is the paper curled?</p> | Go to step 3. | The problem is solved. |
| <p>Step 3</p> <p>a Depending on your operating system, specify the paper size and paper type from the Printing Preferences or Print dialog.</p> <p>Notes:</p> <ul style="list-style-type: none"> • Make sure that the settings match the paper loaded. • You can also change the settings from the printer control panel. <p>b Print the document.</p> <p>Is the paper curled?</p> | Go to step 4. | The problem is solved. |
| <p>Step 4</p> <p>a Remove paper from the tray, and then turn over the paper.</p> <p>b Print the document.</p> <p>Is the paper curled?</p> | Go to step 5. | The problem is solved. |
| <p>Step 5</p> <p>a Load paper from a fresh package.</p> <p>Note: Paper absorbs moisture due to high humidity. Store paper in its original wrapper until you are ready to use it.</p> <p>b Print the document.</p> <p>Is the paper curled?</p> | Go to step 6. | The problem is solved. |
| <p>Step 6</p> <p>a Check if the paper loaded is supported.</p> <p>Note: If paper is not supported, then load a supported one.</p> <p>b Print the document.</p> <p>Is the paper curled?</p> | Contact your dealer . | The problem is solved. |

Print crooked or skewed



Note: Before solving the problem, print the Print Quality Test Pages. From the home screen, touch **Settings** > **Troubleshooting** > **Print Quality Test Pages**.

| Action | Yes | No |
|--|---------------------------------------|------------------------|
| <p>Step 1</p> <ul style="list-style-type: none"> a Pull out the tray. b Remove the paper, and then load paper from a fresh package. Note: Paper absorbs moisture due to high humidity. Store paper in its original wrapper until you are ready to use it. c Squeeze and slide the paper guides to the correct position for the size of the paper you are loading. d Insert the tray. e Print the document. <p>Is the print crooked or skewed?</p> | Go to step 2. | The problem is solved. |
| <p>Step 2</p> <ul style="list-style-type: none"> a Check if you are printing on a supported paper. b Print the document. <p>Is the print crooked or skewed?</p> | Contact your dealer . | The problem is solved. |

Solid black pages



Note: Before solving the problem, print the Print Quality Test Pages. From the home screen, touch **Settings** > **Troubleshooting** > **Print Quality Test Pages**.

| Action | Yes | No |
|---|---------------------------------------|------------------------|
| <p>Step 1</p> <p>a Check if the printer is using a genuine and supported toner cartridge.</p> <p>Note: If the cartridge is not supported, then install a supported one.</p> <p>b Print the document.</p> <p>Is the printer printing solid black pages?</p> | Go to step 2. | The problem is solved. |
| <p>Step 2</p> <p>a Remove the imaging unit.</p> <p>Warning—Potential Damage: Do not expose the imaging unit to direct light for more than 10 minutes. Extended exposure to light may cause print quality problems.</p> <p>Warning—Potential Damage: Do not touch the photoconductor drum under the imaging unit. Doing so may affect the quality of future print jobs.</p> <p>b Remove any packing material that is stuck on the imaging unit.</p> <p>Note: Make sure to remove any obstruction between the charge roller and photoconductor drum.</p> <p>c Insert the imaging unit.</p> <p>d Print the document.</p> <p>Is the printer printing solid black pages?</p> | Go to step 3. | The problem is solved. |
| <p>Step 3</p> <p>Check the imaging unit for signs of damage.</p> <p>Is the imaging unit free from damage?</p> | Contact your dealer . | Go to step 4. |
| <p>Step 4</p> <p>a Replace the imaging unit.</p> <p>b Print the document.</p> <p>Is the printer printing solid black pages?</p> | Contact your dealer . | The problem is solved. |

Text or images cut off



Note: Before solving the problem, print the Print Quality Test Pages. From the home screen, touch **Settings** > **Troubleshooting** > **Print Quality Test Pages**.

| Action | Yes | No |
|--|---------------------------------------|------------------------|
| <p>Step 1</p> <p>a Check if the printer is using a genuine and supported toner cartridge.</p> <p>Note: If the cartridge is not supported, then install a supported one.</p> <p>b Print the document.</p> <p>Are text or images cut off?</p> | Go to step 2. | The problem is solved. |
| <p>Step 2</p> <p>a Remove the imaging unit.</p> <p>Warning—Potential Damage: Do not expose the imaging unit to direct light for more than 10 minutes. Extended exposure to light may cause print quality problems.</p> <p>Warning—Potential Damage: Do not touch the photoconductor drum under the imaging unit. Doing so may affect the quality of future print jobs.</p> <p>b Remove any packing material that is stuck on the imaging unit.</p> <p>Note: Make sure to remove any obstruction between the charge roller and photoconductor drum.</p> <p>c Insert the imaging unit.</p> <p>d Print the document.</p> <p>Are text or images cut off?</p> | Go to step 3. | The problem is solved. |
| <p>Step 3</p> <p>a Replace the imaging unit.</p> <p>b Print the document.</p> <p>Are text or images cut off?</p> | Contact your dealer . | The problem is solved. |

Toner easily rubs off



Note: Before solving the problem, print the Print Quality Test Pages. From the home screen, touch **Settings** > **Troubleshooting** > **Print Quality Test Pages**.

| Action | Yes | No |
|--|---------------------------------------|------------------------|
| <p>Step 1</p> <p>a Check if the printer is using a genuine and supported toner cartridge.</p> <p>Note: If the cartridge is not supported, then install a supported one.</p> <p>b Print the document.</p> <p>Does toner easily rub off?</p> | Go to step 2. | The problem is solved. |
| <p>Step 2</p> <p>a Depending on your operating system, specify the paper type from the Printing Preferences or Print dialog.</p> <p>Notes:</p> <ul style="list-style-type: none"> • Make sure that the setting matches the paper loaded. • You can also change the setting on the printer control panel. From the home screen, touch Settings > Paper > Tray Configuration > Paper Size/Type. <p>b Print the document.</p> <p>Does toner easily rub off?</p> | Contact your dealer . | The problem is solved. |

Horizontal light bands



Note: Before solving the problem, print the Print Quality Test Pages. From the home screen, touch **Settings > Troubleshooting > Print Quality Test Pages**.

| Action | Yes | No |
|---|---------------|------------------------|
| <p>Step 1</p> <p>a Check if the printer is using a genuine and supported toner cartridge.</p> <p>Note: If the cartridge is not supported, then install a supported one.</p> <p>b Print the document.</p> <p>Do horizontal light bands appear on prints?</p> | Go to step 2. | The problem is solved. |

| Action | Yes | No |
|--|---------------------------------------|------------------------|
| <p>Step 2</p> <p>a Remove, and then insert the imaging unit.</p> <p>Warning—Potential Damage: Do not expose the imaging unit to direct light. Extended exposure to light may cause print quality problems.</p> <p>Warning—Potential Damage: Do not touch the photoconductor drum. Doing so may affect the quality of future print jobs.</p> <p>b Print the document.</p> <p>Do horizontal light bands appear on prints?</p> | Go to step 3. | The problem is solved. |
| <p>Step 3</p> <p>a Replace the imaging unit.</p> <p>b Print the document.</p> <p>Do horizontal light bands appear on prints?</p> | Go to step 4. | The problem is solved. |
| <p>Step 4</p> <p>a Turn off the printer, wait for 10 seconds, and then turn on the printer.</p> <p>b Print the document.</p> <p>Do horizontal light bands appear on prints?</p> | Contact your dealer . | The problem is solved. |

Vertical light bands



Note: Before solving the problem, print the Print Quality Test Pages. From the home screen, touch **Settings** > **Troubleshooting** > **Print Quality Test Pages**.

| Action | Yes | No |
|--|---------------------------------------|------------------------|
| <p>a Check if the printer is using a genuine and supported toner cartridge.</p> <p>Note: If the cartridge is not supported, then install a supported one.</p> <p>b Print the document.</p> <p>Do vertical light bands appear on prints?</p> | Contact your dealer . | The problem is solved. |

Vertical white lines



Note: Before solving the problem, print the Print Quality Test Pages. From the home screen, touch **Settings** > **Troubleshooting** > **Print Quality Test Pages**.

| Action | Yes | No |
|--|---------------------------------------|------------------------|
| <p>Step 1</p> <p>a Check if the printer is using a genuine and supported toner cartridge.</p> <p>Note: If the cartridge is not supported, then install a supported one.</p> <p>b Print the document.</p> <p>Do vertical white lines appear on prints?</p> | Go to step 2. | The problem is solved. |
| <p>Step 2</p> <p>a Depending on your operating system, specify the paper type from the Printing Preferences or Print dialog.</p> <p>Notes:</p> <ul style="list-style-type: none"> • Make sure that the setting matches the paper loaded. • You can also change the setting on the printer control panel. From the home screen, touch Settings > Paper > Tray Configuration > Paper Size/Type. <p>b Print the document.</p> <p>Do vertical white lines appear on prints?</p> | Contact your dealer . | The problem is solved. |

Vertical dark bands



Note: Before solving the problem, print the Print Quality Test Pages. From the home screen, touch **Settings** > **Troubleshooting** > **Print Quality Test Pages**.

| Action | Yes | No |
|---|---|-------------------------------|
| <p>Step 1</p> <p>a Check if the printer is using a genuine and supported toner cartridge.</p> <p>Note: If the cartridge is not supported, then install a supported one.</p> <p>b Print the document.</p> <p>Do vertical dark bands appear on prints?</p> | <p>Go to step 2.</p> | <p>The problem is solved.</p> |
| <p>Step 2</p> <p>a Remove the toner cartridge, and then remove the imaging unit.</p> <p>Warning—Potential Damage: Do not expose the imaging unit to direct light for more than 10 minutes. Extended exposure to light may cause print quality problems.</p> <p>Warning—Potential Damage: Do not touch the photoconductor drum under the imaging unit. Doing so may affect the quality of future print jobs.</p> <p>b Insert the imaging unit, and then insert the cartridge.</p> <p>c Print the document.</p> <p>Do vertical dark bands appear on prints?</p> | <p>Go to step 3.</p> | <p>The problem is solved.</p> |
| <p>Step 3</p> <p>a Remove the imaging unit.</p> <p>Warning—Potential Damage: Do not expose the imaging unit to direct light for more than 10 minutes. Extended exposure to light may cause print quality problems.</p> <p>Warning—Potential Damage: Do not touch the photoconductor drum under the imaging unit. Doing so may affect the quality of future print jobs.</p> <p>b Remove any packing material that is stuck on the imaging unit.</p> <p>Note: Make sure to remove any obstruction between the charge roller and photoconductor drum.</p> <p>c Insert the imaging unit.</p> <p>d Print the document.</p> <p>Do vertical dark bands appear on prints?</p> | <p>Go to step 4.</p> | <p>The problem is solved.</p> |
| <p>Step 4</p> <p>a Check if a bright light enters the right side of the printer, and move the printer if necessary.</p> <p>b Print the document.</p> <p>Do vertical dark bands appear on prints?</p> | <p>Contact your dealer.</p> | <p>The problem is solved.</p> |

Vertical dark lines or streaks



Note: Before solving the problem, print the Print Quality Test Pages. From the home screen, touch **Settings** > **Troubleshooting** > **Print Quality Test Pages**.

| Action | Yes | No |
|--|---------------------------------------|------------------------|
| <p>Step 1</p> <p>a From the home screen, touch Settings > Troubleshooting > Cleaning the Scanner</p> <p>b Print the document.</p> <p>Do vertical dark lines or streaks appear on prints?</p> | Go to step 3. | Go to step 2. |
| <p>Step 2</p> <p>a Using a damp, soft, lint-free cloth, clean the scanner. For more information, see “Cleaning the scanner” on page 201.</p> <p>b Copy the document using the ADF.</p> <p>Do vertical dark lines or streaks appear on prints?</p> | Contact your dealer . | The problem is solved. |
| <p>Step 3</p> <p>a Check if the printer is using a genuine and supported toner cartridge.</p> <p>Note: If the cartridge is not supported, then install a supported one.</p> <p>b Print the document.</p> <p>Do vertical dark lines or streaks appear on prints?</p> | Go to step 4. | The problem is solved. |
| <p>Step 4</p> <p>a Remove, and then insert the imaging unit.</p> <p>Warning—Potential Damage: Do not expose the imaging unit to direct light for more than 10 minutes. Extended exposure to light can cause print quality problems.</p> <p>Warning—Potential Damage: Do not touch the photoconductor drum under the imaging unit. Doing so may affect the quality of future print jobs.</p> <p>b Print the document.</p> <p>Do vertical dark lines or streaks appear on prints?</p> | Go to step 5. | The problem is solved. |

| Action | Yes | No |
|---|---------------------------------------|------------------------|
| <p>Step 5</p> <p>a Replace the imaging unit.</p> <p>b Print the document.</p> <p>Do vertical dark lines or streaks appear on prints?</p> | Contact your dealer . | The problem is solved. |

Vertical dark streaks with print missing

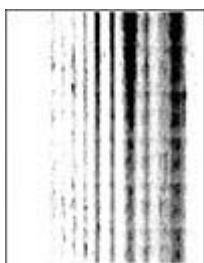

Note: Before solving the problem, print the Print Quality Test Pages. From the home screen, touch **Settings > Troubleshooting > Print Quality Test Pages**.

| Action | Yes | No |
|---|---------------------------------------|------------------------|
| <p>Step 1</p> <p>a Check if the printer is using a genuine and supported toner cartridge.</p> <p>Note: If the cartridge is not supported, then install a supported one.</p> <p>b Print the document.</p> <p>Do vertical dark streaks with missing images appear on prints?</p> | Go to step 2. | The problem is solved. |
| <p>Step 2</p> <p>a Remove the imaging unit.</p> <p>Warning—Potential Damage: Do not expose the imaging unit to direct light for more than 10 minutes. Extended exposure to light may cause print quality problems.</p> <p>Warning—Potential Damage: Do not touch the photoconductor drum under the imaging unit. Doing so may affect the quality of future print jobs.</p> <p>b Remove any packing material that is stuck on the imaging unit.</p> <p>Note: Make sure to remove any obstruction between the charge roller and photoconductor drum.</p> <p>c Insert the imaging unit.</p> <p>d Print the document.</p> <p>Do vertical dark streaks with missing images appear on prints?</p> | Contact your dealer . | The problem is solved. |

Repeating defects



Note: Before solving the problem, print the Print Quality Test Pages. From the home screen, touch **Settings** > **Troubleshooting** > **Print Quality Test Pages**.

| Action | Yes | No |
|---|---------------------------------------|---|
| <p>Step 1</p> <p>Using the Print Quality Test Pages, check if the distance between the repeating defects is equal to any of the following:</p> <ul style="list-style-type: none"> • 97 mm (3.82 in.) • 47 mm (1.85 in.) • 38 mm (1.5 in.) <p>Does the distance between the repeating defects match any of the measurements?</p> | Go to step 2. | Take note of the distance, and then contact your dealer . |
| <p>Step 2</p> <p>a Replace the imaging unit. b Print the document.</p> <p>Do the repeating defects appear?</p> | Contact your dealer . | The problem is solved. |

Print jobs do not print

| Action | Yes | No |
|--|------------------------|---------------|
| <p>Step 1</p> <p>a From the document you are trying to print, open the Print dialog, and then check if you have selected the correct printer. b Print the document.</p> <p>Is the document printed?</p> | The problem is solved. | Go to step 2. |
| <p>Step 2</p> <p>a Check if the printer is on. b Resolve any error messages that appear on the display. c Print the document.</p> <p>Is the document printed?</p> | The problem is solved. | Go to step 3. |

| Action | Yes | No |
|---|------------------------|---------------------------------------|
| <p>Step 3</p> <p>a Check if the ports are working and if the cables are securely connected to the computer and the printer. For more information, see the setup documentation that came with the printer.</p> <p>b Print the document.</p> <p>Is the document printed?</p> | The problem is solved. | Go to step 4. |
| <p>Step 4</p> <p>a Turn off the printer, wait for about 10 seconds, and then turn on the printer.</p> <p>b Print the document.</p> <p>Is the document printed?</p> | The problem is solved. | Go to step 5. |
| <p>Step 5</p> <p>a Remove, and then reinstall the print driver.</p> <p>b Print the document.</p> <p>Is the document printed?</p> | The problem is solved. | Contact your dealer . |

Confidential and other held documents do not print

| Action | Yes | No |
|--|------------------------|---------------|
| <p>Step 1</p> <p>a From the control panel, check if the documents appear in the Held Jobs list. Note: If the documents are not listed, then print the documents using the Print and Hold options.</p> <p>b Print the documents.</p> <p>Are the documents printed?</p> | The problem is solved. | Go to step 2. |
| <p>Step 2</p> <p>The print job may contain a formatting error or invalid data.</p> <ul style="list-style-type: none"> Delete the print job, and then send it again. For PDF files, generate a new file, and then print the documents. <p>Are the documents printed?</p> | The problem is solved. | Go to step 3. |

| Action | Yes | No |
|--|-------------------------------|---|
| <p>Step 3</p> <p>If you are printing from the Internet, then the printer may be reading the multiple job titles as duplicates.</p> <p>For Windows users</p> <ul style="list-style-type: none"> a Open the Printing Preferences dialog. b From the Print and Hold tab, click Use Print and Hold, and then click Keep duplicate documents. c Enter a PIN, and then save the changes. d Send the print job. <p>For Macintosh users</p> <ul style="list-style-type: none"> a Save and name each job differently. b Send the job individually. <p>Are the documents printed?</p> | <p>The problem is solved.</p> | <p>Go to step 4.</p> |
| <p>Step 4</p> <ul style="list-style-type: none"> a Delete some held jobs to free up printer memory. b Print the documents. <p>Are the documents printed?</p> | <p>The problem is solved.</p> | <p>Go to step 5.</p> |
| <p>Step 5</p> <ul style="list-style-type: none"> a Add printer memory. b Print the documents. <p>Are the documents printed?</p> | <p>The problem is solved.</p> | <p>Contact your dealer.</p> |

Job prints from the wrong tray or on the wrong paper

| Action | Yes | No |
|--|----------------------|--|
| <p>Step 1</p> <ul style="list-style-type: none"> a Check if you are printing on the correct paper. b Print the document. <p>Is the document printed on the correct paper?</p> | <p>Go to step 2.</p> | <p>Load the correct paper size and paper type.</p> |

| Action | Yes | No |
|--|-------------------------------|---|
| <p>Step 2</p> <p>a Depending on your operating system, specify the paper size and paper type from the Printing Preferences or Print dialog.</p> <p>Note: You can also change the settings on the printer control panel. From the home screen, touch Settings > Paper > Tray Configuration > Paper Size/Type.</p> <p>b Make sure that the settings match the paper loaded.</p> <p>c Print the document.</p> <p>Is the document printed on the correct paper?</p> | <p>The problem is solved.</p> | <p>Go to step 3.</p> |
| <p>Step 3</p> <p>a Check if the trays are linked.</p> <p>For more information, see “Linking trays” on page 44.</p> <p>b Print the document.</p> <p>Is the document printed from the correct tray?</p> | <p>The problem is solved.</p> | <p>Contact your dealer.</p> |

Slow printing

| Action | Yes | No |
|--|----------------------|-------------------------------|
| <p>Step 1</p> <p>Make sure that the printer cable is securely connected to the printer and to the computer, print server, option, or other network device.</p> <p>Is the printer printing slow?</p> | <p>Go to step 2.</p> | <p>The problem is solved.</p> |
| <p>Step 2</p> <p>a Make sure that the printer is not in Quiet Mode.</p> <p>From the home screen, touch Settings > Device > Maintenance > Configuration Menu > Device Operations > Quiet Mode.</p> <p>b Print the document.</p> <p>Is the printer printing slow?</p> | <p>Go to step 3.</p> | <p>The problem is solved.</p> |
| <p>Step 3</p> <p>a Depending on your operating system, specify the print resolution from the Printing Preferences or Print dialog.</p> <p>b Set the resolution to 600 dpi.</p> <p>c Print the document.</p> <p>Is the printer printing slow?</p> | <p>Go to step 4.</p> | <p>The problem is solved.</p> |

| Action | Yes | No |
|---|---------------|------------------------|
| <p>Step 4</p> <p>a From the home screen, touch Settings > Print > Quality > Print Resolution.</p> <p>b Set the resolution to 600 dpi.</p> <p>c Print the document.</p> <p>Is the printer printing slow?</p> | Go to step 5. | The problem is solved. |
| <p>Step 5</p> <p>a Depending on your operating system, specify the paper type from the Printing Preferences or Print dialog.</p> <p>Notes:</p> <ul style="list-style-type: none"> • Make sure that the setting matches the paper loaded. • You can also change the setting on the printer control panel. • Heavier paper prints more slowly. • Paper narrower than letter, A4, and legal may print more slowly. <p>b Print the document.</p> <p>Is the printer printing slow?</p> | Go to step 6. | The problem is solved. |
| <p>Step 6</p> <p>a Make sure that the printer settings for texture and weight match the paper being loaded.</p> <p>From the home screen, touch Settings > Paper > Media Configuration > Media Types.</p> <p>Note: Rough paper textures and heavy paper weights may print more slowly.</p> <p>b Print the document.</p> <p>Is the printer printing slow?</p> | Go to step 7. | The problem is solved. |
| <p>Step 7</p> <p>Remove held jobs.</p> <p>Is the printer printing slow?</p> | Go to step 8. | The problem is solved. |

| Action | Yes | No |
|---|---------------------------------------|------------------------|
| <p>Step 8</p> <p>a Make sure that the printer is not overheating.</p> <p>Notes:</p> <ul style="list-style-type: none"> • Allow the printer to cool down after a long print job. • Observe the recommended ambient temperature for the printer. For more information, see “Selecting a location for the printer” on page 17. <p>b Print the document.</p> <p>Is the printer printing slow?</p> | Contact your dealer . | The problem is solved. |

The printer is not responding

| Action | Yes | No |
|--|---|---|
| <p>Step 1</p> <p>Check if the power cord is connected to the electrical outlet.</p> <p> CAUTION—POTENTIAL INJURY: To avoid the risk of fire or electrical shock, connect the power cord to an appropriately rated and properly grounded electrical outlet that is near the product and easily accessible.</p> <p>Is the printer responding?</p> | The problem is solved. | Go to step 2. |
| <p>Step 2</p> <p>Check if the electrical outlet is turned off by a switch or breaker.</p> <p>Is the electrical outlet turned off by a switch or breaker?</p> | Turn on the switch or reset the breaker. | Go to step 3. |
| <p>Step 3</p> <p>Check if the printer is on.</p> <p>Is the printer on?</p> | Go to step 4. | Turn on the printer. |
| <p>Step 4</p> <p>Check if the printer is in Sleep or Hibernate mode.</p> <p>Is the printer in Sleep or Hibernate mode?</p> | Press the power button to wake the printer. | Go to step 5. |
| <p>Step 5</p> <p>Check if the cables connecting the printer and the computer are inserted to the correct ports.</p> <p>Are the cables inserted to the correct ports?</p> | Go to step 6. | Insert the cables to the correct ports. |

| Action | Yes | No |
|---|------------------------|---------------------------------------|
| <p>Step 6</p> <p>Turn off the printer, install the hardware options, and then turn on the printer.</p> <p>For more information, see the documentation that came with the option.</p> <p>Is the printer responding?</p> | The problem is solved. | Go to step 7. |
| <p>Step 7</p> <p>Install the correct print driver.</p> <p>Is the printer responding?</p> | The problem is solved. | Go to step 8. |
| <p>Step 8</p> <p>Turn off the printer, wait for about 10 seconds, and then turn on the printer.</p> <p>Is the printer responding?</p> | The problem is solved. | Contact your dealer . |

Unable to read flash drive

| Action | Yes | No |
|---|------------------------|---------------|
| <p>Step 1</p> <p>Check if the printer is not busy processing another print, copy, scan, or fax job.</p> <p>Is the printer ready?</p> | Go to step 3. | Go to step 2. |
| <p>Step 2</p> <ul style="list-style-type: none"> • Wait for the printer to finish processing the other job. • Remove, and then insert the flash drive. <p>Does the printer recognize the flash drive?</p> | The problem is solved. | Go to step 3. |
| <p>Step 3</p> <p>Check if the flash drive is inserted into the front USB port.</p> <p>Note: The flash drive does not work when it is inserted into the rear USB port.</p> <p>Is the flash drive inserted into the correct port?</p> | Go to step 5. | Go to step 4. |
| <p>Step 4</p> <p>Insert the flash drive into the correct port.</p> <p>Does the printer recognize the flash drive?</p> | The problem is solved. | Go to step 5. |

| Action | Yes | No |
|--|------------------------|---------------------------------------|
| <p>Step 5 Check if the flash drive is supported. For more information, see “Supported flash drives and file types” on page 78.</p> <p>Is the flash drive supported?</p> | Go to step 7. | Go to step 6. |
| <p>Step 6 Insert a supported flash drive.</p> <p>Does the printer recognize the flash drive?</p> | The problem is solved. | Go to step 7. |
| <p>Step 7 Remove, and then insert the flash drive.</p> <p>Does the printer recognize the flash drive?</p> | The problem is solved. | Contact your dealer . |

Enabling the USB port

From the home screen, touch **Settings > Network/Ports > USB > Enable USB Port.**

Clearing jams

Avoiding jams

Load paper properly

- Make sure that the paper lies flat in the tray.

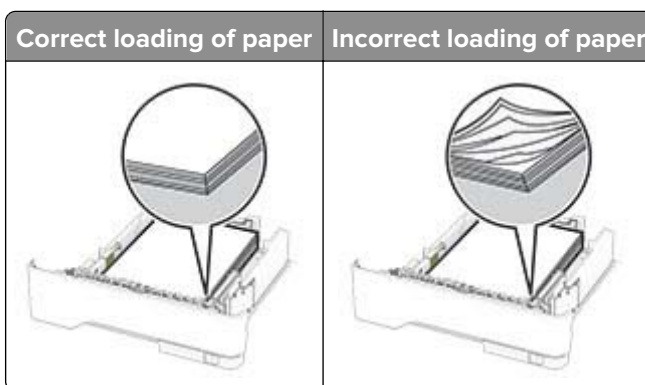

- Do not load or remove a tray while the printer is printing.
- Do not load too much paper. Make sure that the stack height is below the maximum paper fill indicator.

- Do not slide paper into the tray. Load paper as shown in the illustration.

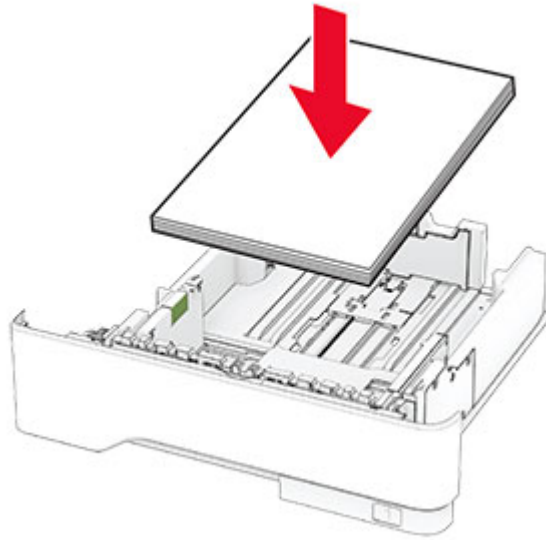

- Make sure that the paper guides are positioned correctly and are not pressing tightly against the paper or envelopes.
- Push the tray firmly into the printer after loading paper.

Use recommended paper

- Use only recommended paper or specialty media.
- Do not load paper that is wrinkled, creased, damp, bent, or curled.
- Flex, fan, and align the paper edges before loading.

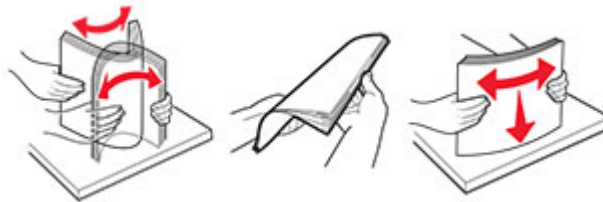

- Do not use paper that has been cut or trimmed by hand.
- Do not mix paper sizes, weights, or types in the same tray.
- Make sure that the paper size and type are set correctly on the computer or printer control panel.
- Store paper according to manufacturer recommendations.

Identifying jam locations

Notes:

- When Jam Assist is set to On, the printer flushes blank pages or pages with partial prints after a jammed page has been cleared. Check your printed output for blank pages.
- When Jam Recovery is set to On or Auto, the printer reprints jammed pages.

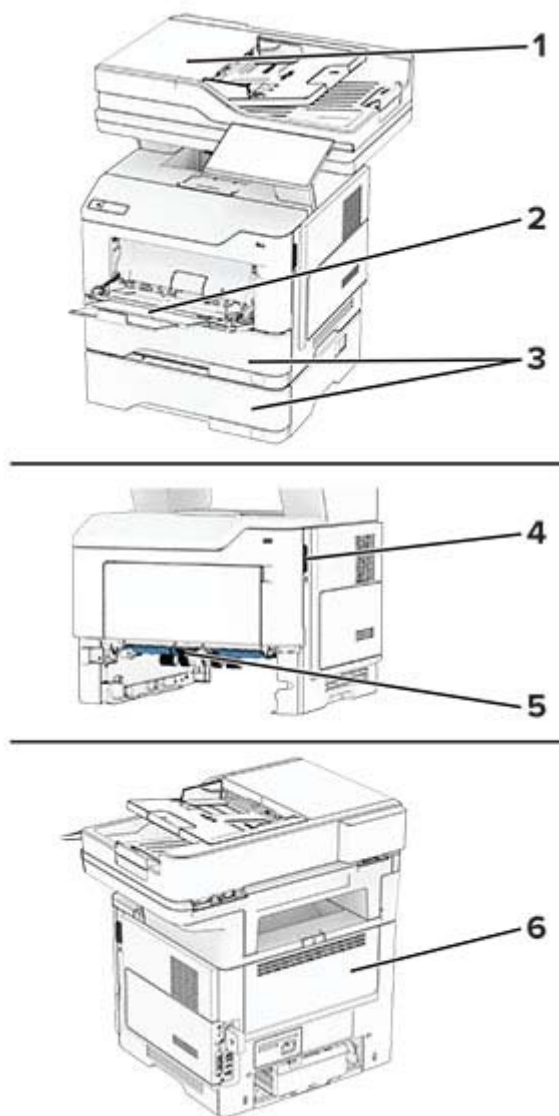

| Jam locations | |
|---------------|---------------------------|
| 1 | Automatic document feeder |
| 2 | Multipurpose feeder |
| 3 | Trays |
| 4 | Door A |
| 5 | Duplex unit |
| 6 | Door B |

Paper jam in door A

1 Open door A.

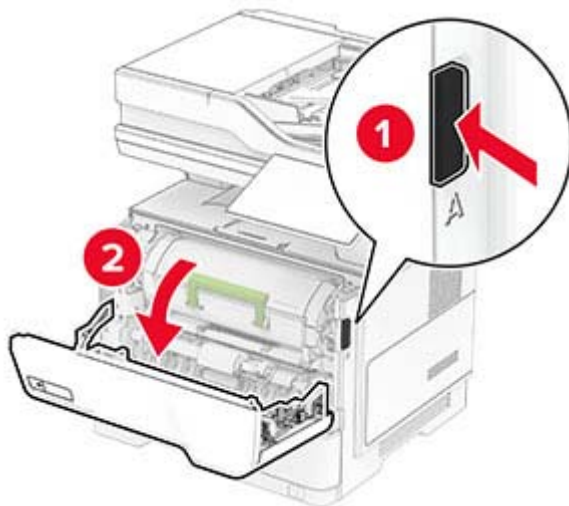

2 Remove the toner cartridge.

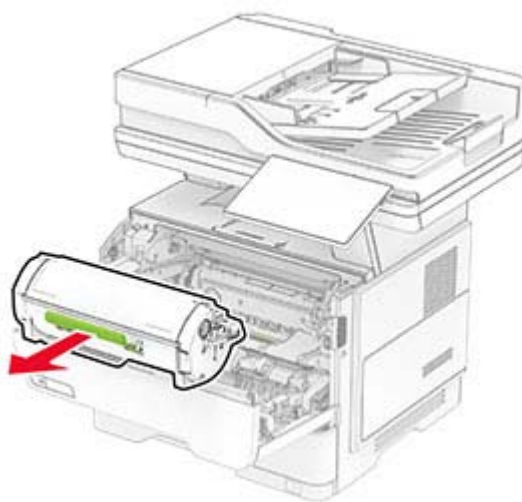

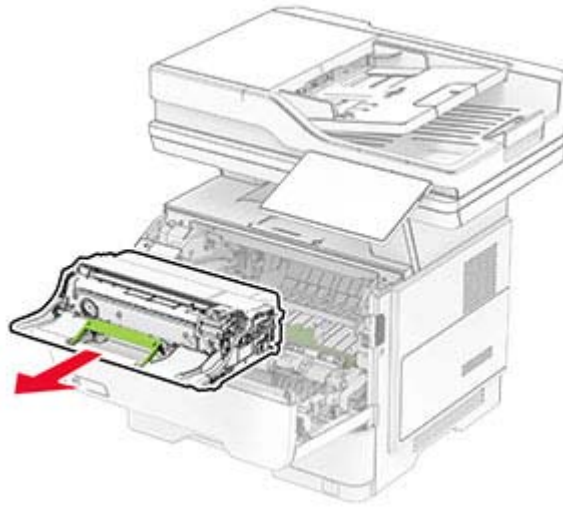
3 Remove the imaging unit.

Warning—Potential Damage: Do not expose the imaging unit to direct light for more than 10 minutes. Extended exposure to light may cause print quality problems.

Warning—Potential Damage: Do not touch the photoconductor drum. Doing so may affect the quality of future print jobs.

**4** Remove the jammed paper.

CAUTION—HOT SURFACE: The inside of the printer might be hot. To reduce the risk of injury from a hot component, allow the surface to cool before touching it.

Note: Make sure that all paper fragments are removed.

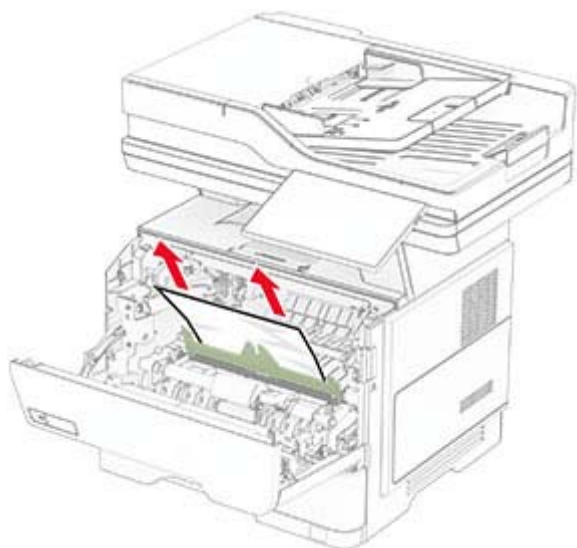

5 Insert the imaging unit.

Note: Use the arrows inside the printer as guides.

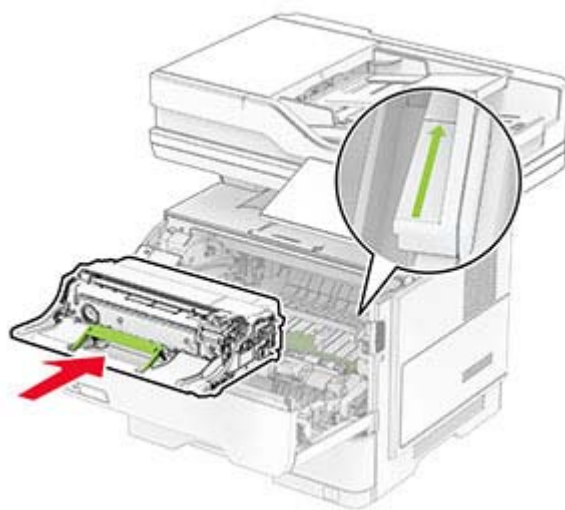

6 Insert the toner cartridge.

Note: Use the arrows inside the printer as guides.

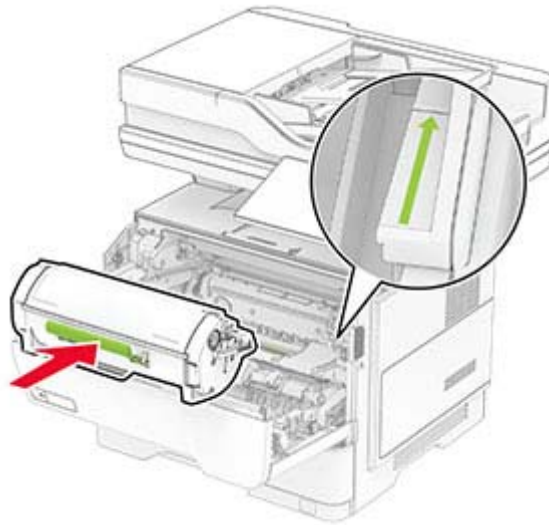

7 Close door A.

Paper jam in door B

1 Open door B.

 **CAUTION—HOT SURFACE:** The inside of the printer might be hot. To reduce the risk of injury from a hot component, allow the surface to cool before touching it.

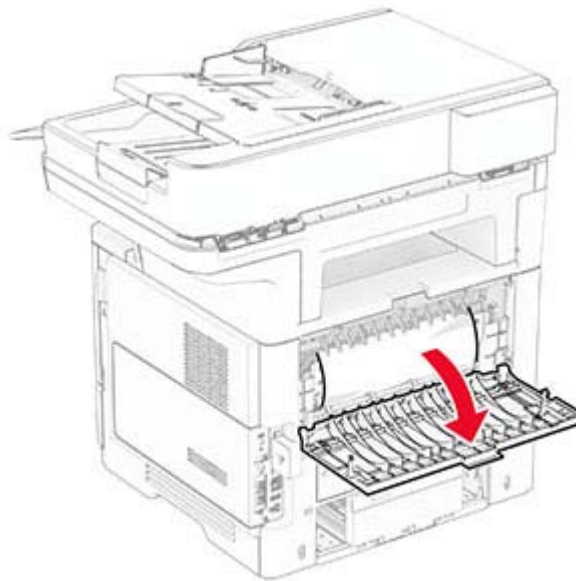

2 Remove the jammed paper.

Note: Make sure that all paper fragments are removed.

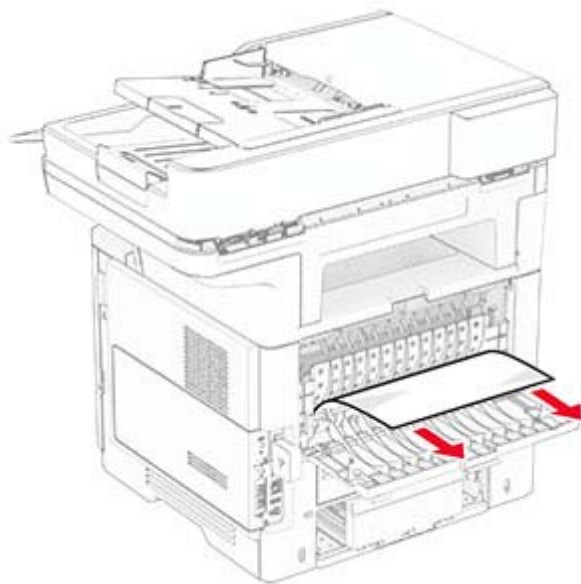

3 Close door B.

Paper jam in the duplex unit

1 Remove the tray.



- 2 Push the duplex unit latch to open the duplex unit.

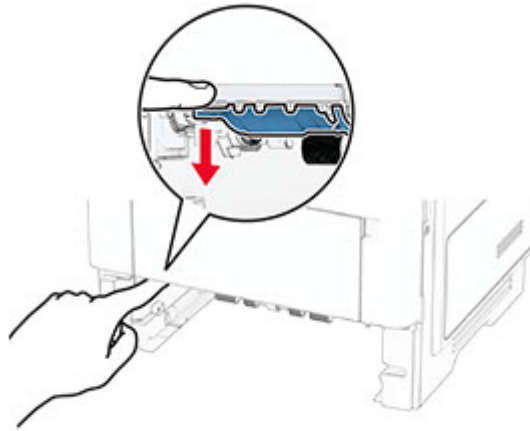

- 3 Remove the jammed paper.

Note: Make sure that all paper fragments are removed.

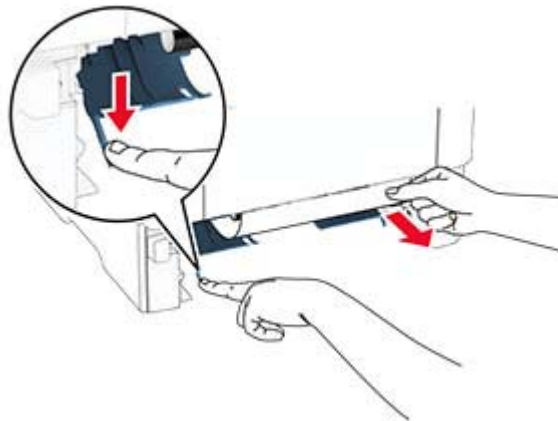

- 4 Insert the tray.

Paper jam in trays

- 1 Remove the tray.

Warning—Potential Damage: To prevent damage from electrostatic discharge, touch any exposed metal frame of the printer before accessing or touching interior areas of the printer.

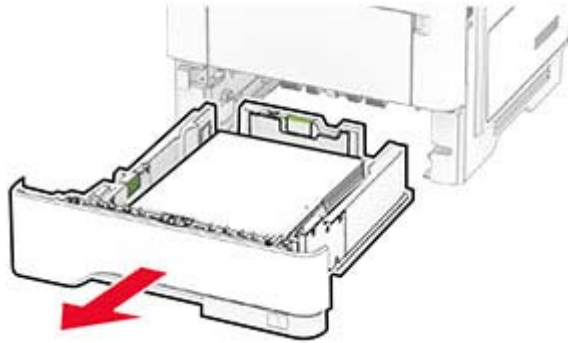

2 Remove the jammed paper.

Note: Make sure that all paper fragments are removed.

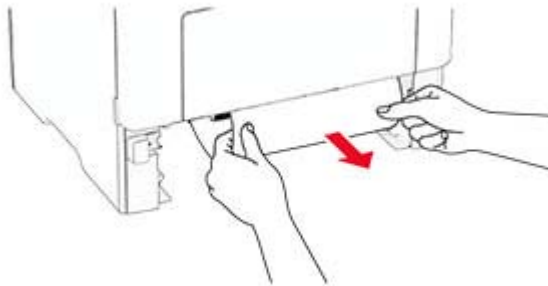

3 Insert the tray.

Paper jam in the multipurpose feeder

1 Remove paper from the multipurpose feeder.

2 Remove the jammed paper.

Note: Make sure that all paper fragments are removed.



- 3 Reload paper, and then adjust the paper guide.

Paper jam in the automatic document feeder

Paper jam under the ADF top cover

- 1 Remove all original documents from the ADF tray.
- 2 Open door C.

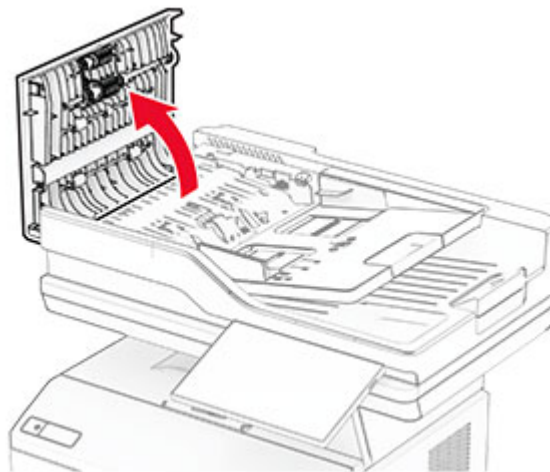

- 3 Remove the jammed paper.

Note: Make sure that all paper fragments are removed.

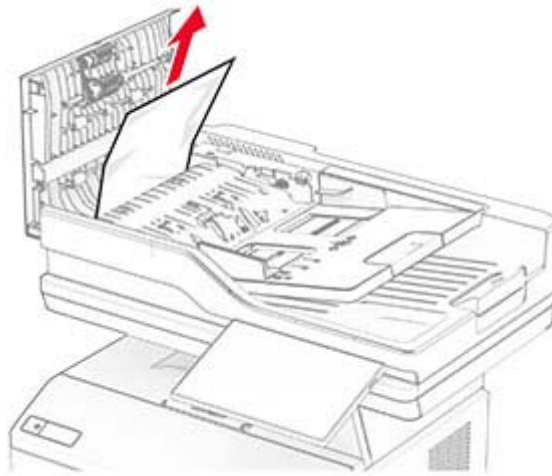

4 Close door C.

Paper jam under the ADF output bin

- 1** Remove all original documents from the ADF tray.
- 2** Lift the ADF tray, and then remove the jammed paper.

Note: Make sure that all paper fragments are removed.

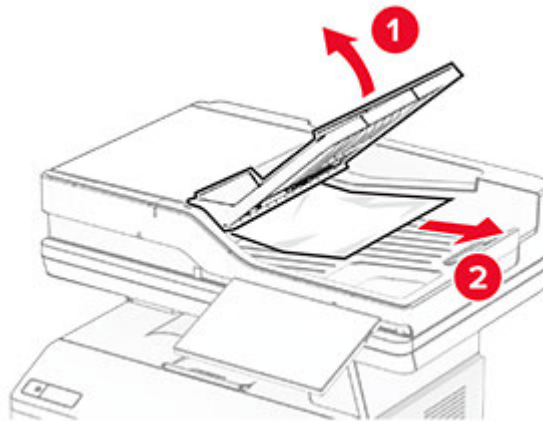

3 Place the ADF tray back into place.

Network connection problems

Cannot open Embedded Web Server

| Action | Yes | No |
|---|------------------------|---------------|
| <p>Step 1</p> <p>a Check if the printer is on.</p> <p>b Access the printer Embedded Web Server (EWS).</p> <p>Can you open the EWS?</p> | The problem is solved. | Go to step 2. |
| <p>Step 2</p> <p>a Make sure that the printer IP address is correct.</p> <p>Notes:</p> <ul style="list-style-type: none"> • View the IP address on the home screen. • An IP address appears as four sets of numbers separated by periods, such as 123.123.123.123. <p>b Access the EWS.</p> <p>Can you open the EWS?</p> | The problem is solved. | Go to step 3. |
| <p>Step 3</p> <p>a Make sure that you installed a supported browser:</p> <ul style="list-style-type: none"> • Internet Explorer version 11 or later • Microsoft Edge • Safari version 6 or later • Google Chrome™ version 32 or later • Mozilla Firefox version 24 or later <p>b Access the EWS.</p> <p>Can you open the EWS?</p> | The problem is solved. | Go to step 4. |
| <p>Step 4</p> <p>a Check if the network connection is working.</p> <p>Note: If the connection is not working, then contact your administrator.</p> <p>b Access the EWS.</p> <p>Can you open the EWS?</p> | The problem is solved. | Go to step 5. |
| <p>Step 5</p> <p>a Make sure that the cable connections to the printer and print server are secure. For more information, see the documentation that came with the print server.</p> <p>b Access the EWS.</p> <p>Can you open the EWS?</p> | The problem is solved. | Go to step 6. |

| Action | Yes | No |
|--|-------------------------------|---|
| <p>Step 6</p> <p>a Check if the web proxy servers are disabled.</p> <p>Note: If the servers are disabled, then contact your administrator.</p> <p>b Access the EWS.</p> <p>Can you open the EWS?</p> | <p>The problem is solved.</p> | <p>Contact your dealer.</p> |

Cannot connect the printer to the Wi-Fi network

| Action | Yes | No |
|---|-------------------------------|---|
| <p>Step 1</p> <p>Make sure that Active Adapter is set to Auto.</p> <p>From the home screen, touch Settings > Network/Ports > Network Overview > Active Adapter > Auto.</p> <p>Can the printer connect to the Wi-Fi network?</p> | <p>The problem is solved.</p> | <p>Go to step 2.</p> |
| <p>Step 2</p> <p>Check if the correct Wi-Fi network is selected.</p> <p>Note: Some routers may share the default SSID.</p> <p>Are you connecting to the correct Wi-Fi network?</p> | <p>Go to step 4.</p> | <p>Go to step 3.</p> |
| <p>Step 3</p> <p>Connect to the correct Wi-Fi network. For more information, see “Connecting the printer to a Wi-Fi network” on page 71.</p> <p>Can the printer connect to the Wi-Fi network?</p> | <p>The problem is solved.</p> | <p>Go to step 4.</p> |
| <p>Step 4</p> <p>Check the wireless security mode.</p> <p>From the home screen, touch Settings > Network/Ports > Wireless > Wireless Security Mode.</p> <p>Is the correct wireless security mode selected?</p> | <p>Go to step 6.</p> | <p>Go to step 5.</p> |
| <p>Step 5</p> <p>Select the correct wireless security mode.</p> <p>Can the printer connect to the Wi-Fi network?</p> | <p>The problem is solved.</p> | <p>Go to step 6.</p> |
| <p>Step 6</p> <p>Make sure that you entered the correct network password.</p> <p>Note: Take note of the spaces, numbers, and capitalization in the password.</p> <p>Can the printer connect to the Wi-Fi network?</p> | <p>The problem is solved.</p> | <p>Contact your dealer.</p> |

Hardware options problems

Cannot detect internal option

| Action | Yes | No |
|---|------------------------|---------------------------------------|
| <p>Step 1 Turn off the printer, wait for about 10 seconds, and then turn on the printer.</p> <p>Does the printer detect the internal option?</p> | The problem is solved. | Go to step 2. |
| <p>Step 2 Print the Menu Settings Page, and then check if the internal option appears in the Installed Features list.</p> <p>Is the internal option listed?</p> | Go to step 4. | Go to step 3. |
| <p>Step 3 Check if the internal option is installed properly into the controller board.</p> <ul style="list-style-type: none"> a Turn off the printer, and then unplug the power cord from the electrical outlet. b Make sure that the internal option is installed into the appropriate connector on the controller board. c Connect the power cord to the electrical outlet, and then turn on the printer. <p> CAUTION—POTENTIAL INJURY: To avoid the risk of fire or electrical shock, connect the power cord to an appropriately rated and properly grounded electrical outlet that is near the product and easily accessible.</p> <p>Does the printer detect the internal option?</p> | The problem is solved. | Go to step 4. |
| <p>Step 4</p> <ul style="list-style-type: none"> a Check if the internal option is available in the print driver. Note: If necessary, manually add the internal option in the print driver to make it available for print jobs. For more information, see “Adding available options in the print driver” on page 47. b Print the document. <p>Does the printer detect the internal option?</p> | The problem is solved. | Contact your dealer . |

Defective flash detected

Contact your [dealer](#).

Not enough free space in flash memory for resources

Contact your [dealer](#).

Red light on the convenience stapler

Try one or more of the following:

- Close the staple access door.
- Remove the loose staples.

Note: After removing loose staples, two priming cycles are required before stapling. Insert a stack of paper into the stapler three times. The stapling starts at the third insertion.

- Replace the staple cartridge.

Issues with supplies

Replace cartridge, printer region mismatch

Install the correct toner cartridge.

Non-Printer Manufacturer supply

The printer has detected an unrecognized supply or part installed in the printer.

Your printer is designed to function best with genuine supplies and parts made by the printer manufacturer. Use of third-party supplies or parts may affect the performance, reliability, or life of the printer and its imaging components.

All life indicators are designed to function with supplies and parts from the printer manufacturer and may deliver unpredictable results if third-party supplies or parts are used. Imaging component usage beyond the intended life may damage your printer or associated components.

Warning—Potential Damage: Use of third-party supplies or parts can affect warranty coverage. Damage caused by the use of third-party supplies or parts may not be covered by the warranty.

To accept any and all of these risks and to proceed with the use of non-genuine supplies or parts in your printer, touch and hold the error message on the display using two fingers for 15 seconds. When a confirmation dialog box appears, touch **Continue**.

If you do not want to accept these risks, then remove the third-party supply or part from your printer and install a genuine supply or part from the printer manufacturer.

If the printer does not print after clearing the error message, then reset the supply usage counter.

Paper feed problems

Envelope seals when printing

| Action | Yes | No |
|---|---------------------------------------|------------------------|
| <p>Step 1</p> <p>a Use an envelope that has been stored in a dry environment. Note: Printing on envelopes with high moisture content can seal the flaps.</p> <p>b Send the print job.</p> <p>Does the envelope seal when printing?</p> | Go to step 2. | The problem is solved. |
| <p>Step 2</p> <p>a Make sure that paper type is set to Envelope. From the home screen, touch Settings > Paper > Tray Configuration > Paper Size/Type.</p> <p>b Send the print job.</p> <p>Does the envelope seal when printing?</p> | Contact your dealer . | The problem is solved. |

Collated printing does not work

| Action | Yes | No |
|---|------------------------|---------------------------------------|
| <p>Step 1</p> <p>a From the home screen, touch Settings > Print > Layout > Collate.</p> <p>b Touch On [1,2,1,2,1,2].</p> <p>c Print the document.</p> <p>Is the document collated correctly?</p> | The problem is solved. | Go to step 2. |
| <p>Step 2</p> <p>a From the document that you are trying to print, open the Print dialog, and then select Collate.</p> <p>b Print the document.</p> <p>Is the document collated correctly?</p> | The problem is solved. | Go to step 3. |
| <p>Step 3</p> <p>a Reduce the number of pages to print.</p> <p>b Print the document.</p> <p>Are the pages collated correctly?</p> | The problem is solved. | Contact your dealer . |

Tray linking does not work

| Action | Yes | No |
|--|------------------------|---------------------------------------|
| <p>Step 1</p> <p>a Check if the trays contain the same paper size and paper type.</p> <p>b Check if the paper guides are positioned correctly.</p> <p>c Print the document.</p> <p>Do the trays link correctly?</p> | The problem is solved. | Go to step 2. |
| <p>Step 2</p> <p>a From the home screen, touch Settings > Paper > Tray Configuration > Paper Size/Type.</p> <p>b Set the paper size and paper type to match the paper loaded in the linked trays.</p> <p>c Print the document.</p> <p>Do the trays link correctly?</p> | The problem is solved. | Go to step 3. |
| <p>Step 3</p> <p>a Make sure that Tray Linking is set to Automatic. For more information, see “Linking trays” on page 44.</p> <p>b Print the document.</p> <p>Do the trays link correctly?</p> | The problem is solved. | Contact your dealer . |

Paper frequently jams

| Action | Yes | No |
|--|---------------|------------------------|
| <p>Step 1</p> <p>a Remove the tray.</p> <p>b Check if paper is loaded correctly.</p> <p>Notes:</p> <ul style="list-style-type: none"> • Make sure that the paper guides are positioned correctly. • Make sure that the stack height is below the maximum paper fill indicator. • Make sure to print on recommended paper size and type. <p>c Insert the tray.</p> <p>d Print the document.</p> <p>Do paper jams occur frequently?</p> | Go to step 2. | The problem is solved. |

| Action | Yes | No |
|--|---------------------------------------|------------------------|
| <p>Step 2</p> <p>a From the home screen, touch Settings > Paper > Tray Configuration > Paper Size/Type.</p> <p>b Set the correct paper size and type.</p> <p>c Print the document.</p> <p>Do paper jams occur frequently?</p> | Go to step 3. | The problem is solved. |
| <p>Step 3</p> <p>a Load paper from a fresh package.</p> <p>Note: Paper absorbs moisture due to high humidity. Store paper in its original wrapper until you are ready to use it.</p> <p>b Print the document.</p> <p>Do paper jams occur frequently?</p> | Contact your dealer . | The problem is solved. |

Jammed pages are not reprinted

| Action | Yes | No |
|--|------------------------|---------------------------------------|
| <p>a From the home screen, touch Settings > Device > Notifications > Jam Content Recovery.</p> <p>b In the Jam Recovery menu, touch On or Auto.</p> <p>c Print the document.</p> <p>Are the jammed pages reprinted?</p> | The problem is solved. | Contact your dealer . |

E-mailing problems

Disabling the “SMTP server not set up” error message

From the home screen, touch **Settings > E-mail > E-mail Setup > Disable “SMTP Server not set up” error > On**.

To prevent the error from happening again, do one or more of the following:

- Update the printer firmware. For more information, see [“Updating firmware” on page 46](#).
- Configure the e-mail SMTP settings. For more information, see [“Configuring the e-mail SMTP settings” on page 33](#).

Cannot send e-mails

| Action | Yes | No |
|--|------------------------|---------------------------------------|
| <p>Step 1 Make sure that the e-mail SMTP settings are configured correctly. For more information, see “Configuring the e-mail SMTP settings” on page 33.</p> <p>Can you send an e-mail?</p> | The problem is solved. | Go to step 2. |
| <p>Step 2 Make sure that you are using the correct password. Depending on your e-mail service provider, use your account password, app password, or authentication password. For more information, see “Configuring the e-mail SMTP settings” on page 33.</p> <p>Can you send an e-mail?</p> | The problem is solved. | Go to step 3. |
| <p>Step 3 Make sure that the printer is connected to a network and that the network is connected to the Internet.</p> <p>Can you send an e-mail?</p> | The problem is solved. | Contact your dealer . |

Faxing problems

Caller ID is not shown

Note: These instructions apply only to printers that support analog fax. For more information, see the [Setting up the printer to fax](#) section.

| Action | Yes | No |
|--|------------------------|---------------------------------------|
| <p>Enable caller ID. From the home screen, touch Settings > Fax > Fax Setup > Fax Receive Settings > Admin Controls > Enable Caller ID.</p> <p>Does the caller ID appear?</p> | The problem is solved. | Contact your dealer . |

Cannot send or receive faxes using analog fax

| Action | Yes | No |
|--|------------------------|---------------|
| <p>Step 1 Resolve any error messages that appear on the display.</p> <p>Can you send or receive a fax?</p> | The problem is solved. | Go to step 2. |
| <p>Step 2 Make sure that the cable connections for the following equipment are secure:</p> <ul style="list-style-type: none"> • Telephone • Handset • Answering machine <p>Can you send or receive a fax?</p> | The problem is solved. | Go to step 3. |
| <p>Step 3 Check for a dial tone.</p> <ul style="list-style-type: none"> • Call the fax number to check if it is working properly. • If you are using the On Hook Dial feature, then turn up the volume to check if you hear a dial tone. <p>Can you hear a dial tone?</p> | Go to step 5. | Go to step 4. |
| <p>Step 4 Check the telephone wall jack.</p> <ol style="list-style-type: none"> a Connect the analog telephone directly to the wall jack. b Listen for a dial tone. c If you do not hear a dial tone, then use a different telephone cable. d If you still do not hear a dial tone, then connect the analog telephone to a different wall jack. e If you hear a dial tone, then connect the printer to that wall jack. <p>Can you send or receive a fax?</p> | The problem is solved. | Go to step 5. |

| Action | Yes | No |
|---|-------------------------------|---|
| <p>Step 5</p> <p>Check if the printer is connected to an analog phone service or to the correct digital connector.</p> <ul style="list-style-type: none"> • If you are using an Integrated Services for Digital Network (ISDN) telephone service, then connect to an analog telephone port of an ISDN terminal adapter. For more information, contact your ISDN provider. • If you are using DSL, then connect to a DSL filter or router that supports analog use. For more information, contact your DSL provider. • If you are using a private branch exchange (PBX) telephone service, then make sure that you are connecting to an analog connection on the PBX. If none exists, then consider installing an analog telephone line for the fax machine. <p>Can you send or receive a fax?</p> | <p>The problem is solved.</p> | <p>Go to step 6.</p> |
| <p>Step 6</p> <p>Temporarily disconnect other equipment and disable other telephone services.</p> <ul style="list-style-type: none"> a Disconnect other equipment (such as answering machines, computers, modems, or telephone line splitters) between the printer and the telephone line. b Disable call waiting and voice mail. For more information, contact your telephone company. <p>Can you send or receive a fax?</p> | <p>The problem is solved.</p> | <p>Go to step 7.</p> |
| <p>Step 7</p> <p>Scan the original document one page at a time.</p> <ul style="list-style-type: none"> a Dial the fax number. b Scan the document. <p>Can you send or receive a fax?</p> | <p>The problem is solved.</p> | <p>Contact your dealer.</p> |

Can receive but not send faxes using analog fax

| Action | Yes | No |
|---|------------------------|---------------------------------------|
| <p>Step 1 Load an original document properly into the ADF tray or on the scanner glass.</p> <p>Can you send faxes?</p> | The problem is solved. | Go to step 2. |
| <p>Step 2 Set up the shortcut number properly.</p> <ul style="list-style-type: none"> • Check if the shortcut number is set for the telephone number that you want to dial. • Dial the telephone number manually. <p>Can you send faxes?</p> | The problem is solved. | Contact your dealer . |

Can send but not receive faxes using analog fax

| Action | Yes | No |
|---|------------------------|---------------------------------------|
| <p>Step 1 Make sure that the paper source is not empty.</p> <p>Can you receive faxes?</p> | The problem is solved. | Go to step 2. |
| <p>Step 2 Check the ring count delay settings. From the home screen, touch Settings > Fax > Fax Setup > Fax Receive Settings > Rings to Answer.</p> <p>Can you receive faxes?</p> | The problem is solved. | Go to step 3. |
| <p>Step 3 If the printer is printing blank pages, then see “Blank or white pages” on page 211.</p> <p>Can you receive faxes?</p> | The problem is solved. | Contact your dealer . |

Poor fax print quality

| Action | Yes | No |
|--|-------------------------------|---|
| <p>Step 1 Make sure that there are no print quality defects.</p> <p>a From the home screen, touch Settings > Troubleshooting > Print Quality Test Pages.</p> <p>b Correct any print quality defects. For more information, see “Print quality is poor” on page 211.</p> <p>Is the fax print quality satisfactory?</p> | <p>The problem is solved.</p> | <p>Go to step 2.</p> |
| <p>Step 2 If you are using an analog fax, then decrease the incoming fax transmission speed.</p> <p>a From the home screen, touch Settings > Fax > Fax Setup > Fax Receive Settings > Admin Controls.</p> <p>b In the Max Speed menu, select a lower transmission speed.</p> <p>Is the fax print quality satisfactory?</p> | <p>The problem is solved.</p> | <p>Contact your dealer.</p> |

Missing information on the fax cover page

| Action | No | Yes |
|---|-------------------------------|---|
| <p>a Turn off the printer, wait for about 10 seconds, and then turn on the printer.</p> <p>b Send or retrieve the fax.</p> <p>Is there missing information on the fax cover page?</p> | <p>The problem is solved.</p> | <p>Contact your dealer.</p> |

Cannot send the fax cover page from the computer

| Action | Yes | No |
|--|-------------------------------|----------------------|
| <p>Step 1</p> <p>a Make sure that the print driver is updated. For more information, see “Installing the printer software” on page 45.</p> <p>b Send the fax.</p> <p>Can you send the fax cover page?</p> | <p>The problem is solved.</p> | <p>Go to step 2.</p> |

| Action | Yes | No |
|--|-------------------------------|---|
| <p>Step 2</p> <p>a From the document that you are trying to fax, open the Print dialog.</p> <p>b Select the printer, and then click Properties, Preferences, Options, or Setup.</p> <p>c Click Fax, and then clear the Always display settings prior to faxing setting.</p> <p>d Send the fax.</p> <p>Can you send the fax cover page?</p> | <p>The problem is solved.</p> | <p>Contact your dealer.</p> |

Scanning problems

Cannot scan to a computer

| Action | Yes | No |
|--|-------------------------------|----------------------|
| <p>Step 1</p> <p>Perform a copy job.</p> <p>Is the copy job successful?</p> | <p>Go to step 3.</p> | <p>Go to step 2.</p> |
| <p>Step 2</p> <p>a Turn off the printer, wait for about 10 seconds, and then turn it back on.</p> <p>b Scan the document.</p> <p>Can you scan the document to a computer?</p> | <p>The problem is solved.</p> | <p>Go to step 3.</p> |
| <p>Step 3</p> <p>Check the printer connectivity.</p> <p>a Print the Network Setup Page. From the home screen, touch Settings > Reports > Network > Network Setup Page.</p> <p>b Check the network status.</p> <p>Is the printer connected to the network?</p> | <p>Go to step 5.</p> | <p>Go to step 4.</p> |
| <p>Step 4</p> <p>a Connect the printer to the network.</p> <p>b Scan the document.</p> <p>Can you scan the document to a computer?</p> | <p>The problem is solved.</p> | <p>Go to step 5.</p> |

| Action | Yes | No |
|--|-------------------------------|---|
| <p>Step 5</p> <p>a Make sure that the printer and the computer are connected to the same network.</p> <p>b Scan the document.</p> <p>Can you scan the document to a computer?</p> | <p>The problem is solved.</p> | <p>Contact your dealer.</p> |

Cannot scan to a network folder

| Action | Yes | No |
|--|-------------------------------|----------------------|
| <p>Step 1</p> <p>a Create a network folder shortcut.</p> <p>b Scan a document using the shortcut. For more information, see “Scanning to a network folder” on page 90.</p> <p>Can you scan a document and save it to a network folder?</p> | <p>The problem is solved.</p> | <p>Go to step 2.</p> |
| <p>Step 2</p> <p>Make sure that the network folder path and format are correct. For example, <code>//server_hostname/foldername/path</code>, where server_hostname is a fully qualified domain (FQDN) or IP address.</p> <p>Is the network folder path and format correct?</p> | <p>Go to step 3.</p> | <p>Go to step 4.</p> |
| <p>Step 3</p> <p>Make sure that you have a write access permission to the network folder.</p> <p>Can you scan a document and save it to a network folder?</p> | <p>The problem is solved.</p> | <p>Go to step 4.</p> |

| Action | Yes | No |
|---|-------------------------------|---|
| <p>Step 4</p> <p>Update the network folder shortcut.</p> <p>a Open a web browser, and then type the printer IP address in the address field.</p> <p>Notes:</p> <ul style="list-style-type: none"> View the printer IP address on the home screen. The IP address appears as four sets of numbers separated by periods, such as 123.123.123.123. If you are using a proxy server, then temporarily disable it to load the web page correctly. <p>b Click Shortcuts, and then select a shortcut.</p> <p>Note: If you have multiple shortcut types, then select Network Folder.</p> <p>c In the Share Path field, type the network folder path.</p> <p>Notes:</p> <ul style="list-style-type: none"> If your share path is <code>\\server_hostname\foldername\path</code>, then type <code>//server_hostname/foldername/path</code>. Make sure that you use forward slashes when typing the share path. <p>d From the Authentication menu, select your authentication method.</p> <p>Note: If Authentication is set to “Use assigned username and password,” then in the User Name and Password fields, type your credentials.</p> <p>e Click Save.</p> <p>Can you scan a document and save it to a network folder?</p> | <p>The problem is solved.</p> | <p>Go to step 5.</p> |
| <p>Step 5</p> <p>Make sure that the printer and the network folder are connected to the same network.</p> <p>Can you scan a document and save it to a network folder?</p> | <p>The problem is solved.</p> | <p>Contact your dealer.</p> |

Partial copies of document or photo

| Action | Yes | No |
|---|-------------------------------|----------------------|
| <p>Step 1</p> <p>a Make sure that the document or photo is loaded facedown on the upper left corner of the scanner glass.</p> <p>b Copy the document or photo.</p> <p>Is the document or photo copied correctly?</p> | <p>The problem is solved.</p> | <p>Go to step 2.</p> |

| Action | Yes | No |
|---|-------------------------------|---|
| <p>Step 2</p> <p>a Match the paper size setting and the paper loaded in the tray.</p> <p>b Copy the document or photo.</p> <p>Is the document or photo copied correctly?</p> | <p>The problem is solved.</p> | <p>Contact your dealer.</p> |

Poor copy quality

| Action | Yes | No |
|---|-------------------------------|---|
| <p>Step 1</p> <p>a Clean the scanner glass and the ADF glass with a damp, soft, lint-free cloth. If your printer has a second ADF glass inside the ADF, then also clean that glass. For more information, see “Cleaning the scanner” on page 201.</p> <p>b Make sure that the document or photo is loaded facedown on the upper left corner of the scanner glass.</p> <p>c Copy the document or photo.</p> <p>Is the copy quality satisfactory?</p> | <p>The problem is solved.</p> | <p>Go to step 2.</p> |
| <p>Step 2</p> <p>a Check the quality of the original document or photo.</p> <p>b Adjust the scan quality settings.</p> <p>c Copy the document or photo.</p> <p>Is the copy quality satisfactory?</p> | <p>The problem is solved.</p> | <p>Contact your dealer.</p> |

Vertical dark streaks on output when scanning from the ADF

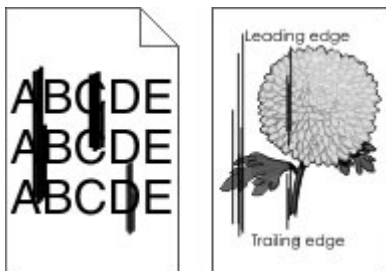

| Action | Yes | No |
|--|---------------------------------------|------------------------|
| <p>a Open the scanner cover.</p> <p>b Using a damp, soft, lint-free cloth, wipe the ADF glass and the ADF glass pad.</p> <p>c Close the scanner cover.</p> <p>d Scan the document.</p> <p>Do vertical streaks appear on scanned documents?</p> | Contact your dealer . | The problem is solved. |

Jagged image or text when scanning from the ADF

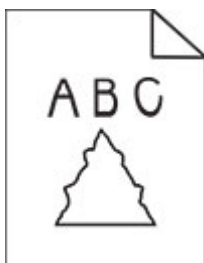

| Action | Yes | No |
|--|---------------------------------------|------------------------|
| <p>a Load 50 sheets of clean, plain paper into the ADF. Note: The plain paper helps clean or remove dust and other coating from the ADF feed rollers.</p> <p>b From the home screen, touch .</p> <p>c Load an original document into the ADF.</p> <p>d Scan the document.</p> <p>Do jagged images or texts appear on the output?</p> | Contact your dealer . | The problem is solved. |

Scan job was not successful

| Action | Yes | No |
|---|------------------------|---------------|
| <p>Step 1 Check the cable connections.</p> <p>a Make sure that the Ethernet or USB cable is securely connected to the computer and the printer.</p> <p>b Scan the document.</p> <p>Is the scan job successful?</p> | The problem is solved. | Go to step 2. |

| Action | Yes | No |
|--|------------------------|---------------------------------------|
| <p>Step 2</p> <p>Check the file that you want to scan.</p> <ul style="list-style-type: none"> a Make sure that the file name is not already used in the destination folder. b Make sure that the document or photo you want to scan is not open in another application. c Scan the document. <p>Is the scan job successful?</p> | The problem is solved. | Go to step 3. |
| <p>Step 3</p> <ul style="list-style-type: none"> a Make sure that the Append time stamp or the Overwrite existing file check box is selected in the destination configuration settings. b Scan the document. <p>Is the scan job successful?</p> | The problem is solved. | Contact your dealer . |

Scanner does not close

| Action | Yes | No |
|--|------------------------|---------------------------------------|
| <p>Remove obstructions that keep the scanner cover open.</p> <p>Did the scanner cover close correctly?</p> | The problem is solved. | Contact your dealer . |

Scanning takes too long or freezes the computer

| Action | Yes | No |
|--|---------------------------------------|------------------------|
| <p>Close all applications that are interfering with the scan.</p> <p>Does scanning take too long or freeze the computer?</p> | Contact your dealer . | The problem is solved. |

Scanner does not respond

| Action | Yes | No |
|---|------------------------|---------------------------------------|
| <p>Step 1</p> <p>a Check if the power cord is connected properly to the printer and the electrical outlet.</p> <p> CAUTION—POTENTIAL INJURY: To avoid the risk of fire or electrical shock, connect the power cord to an appropriately rated and properly grounded electrical outlet that is near the product and easily accessible.</p> <p>b Copy or scan the document.</p> <p>Is the scanner responding?</p> | The problem is solved. | Go to step 2. |
| <p>Step 2</p> <p>a Check if the printer is turned on.</p> <p>b Resolve any error messages that appear on the display.</p> <p>c Copy or scan the document.</p> <p>Is the scanner responding?</p> | The problem is solved. | Go to step 3. |
| <p>Step 3</p> <p>a Turn off the printer, wait for about 10 seconds, and then turn the printer on.</p> <p>b Copy or scan the document.</p> <p>Is the scanner responding?</p> | The problem is solved. | Contact your dealer . |

Adjusting scanner registration

- From the home screen, touch **Settings > Device > Maintenance > Configuration Menu > Scanner Configuration > Scanner Manual Registration**.
- In the Print Quick Test menu, touch **Start**.
- Place the Print Quick Test page on the scanner glass, and then touch **Flatbed Registration**.
- In the Copy Quick Test menu, touch **Start**.
- Compare the Copy Quick Test page with the original document.

Note: If the margins of the test page are different from the original document, then adjust Left Margin and Top Margin.
- Repeat [step 4](#) and [step 5](#) until the margins of the Copy Quick Test page closely match the original document.

Adjusting ADF registration

- From the home screen, touch **Settings > Device > Maintenance > Configuration Menu > Scanner Configuration > Scanner Manual Registration**.
- In the Print Quick Test menu, touch **Start**.

3 Place the Print Quick Test page on the ADF tray.

4 Touch **Front ADF Registration** or **Rear ADF Registration**.

Notes:

- To align Front ADF Registration, place the test page faceup, short edge first into the ADF.
- To align Rear ADF Registration, place the test page facedown, short edge first into the ADF.

5 In the Copy Quick Test menu, touch **Start**.

6 Compare the Copy Quick Test page with the original document.

Note: If the margins of the test page are different from the original document, then adjust Horizontal Adjust and Top Margin.

7 Repeat [step 5](#) and [step 6](#) until the margins of the Copy Quick Test page closely match the original document.

Contacting your dealer

Before contacting your dealer, make sure to have the following information:

- Printer problem
- Error message
- Printer model type and serial number

Notices

Product information

Product name:

DIGITAL MULTIFUNCTIONAL SYSTEM
MX-B468F

Machine type:

7020

Model:

4H6

Edition notice

April 2023

The following paragraph does not apply to any country where such provisions are inconsistent with local law: THIS PUBLICATION IS PROVIDED "AS IS" WITHOUT WARRANTY OF ANY KIND, EITHER EXPRESS OR IMPLIED, INCLUDING, BUT NOT LIMITED TO, THE IMPLIED WARRANTIES OF MERCHANTABILITY OR FITNESS FOR A PARTICULAR PURPOSE. Some states do not allow disclaimer of express or implied warranties in certain transactions; therefore, this statement may not apply to you.

This publication could include technical inaccuracies or typographical errors. Changes are periodically made to the information herein; these changes will be incorporated in later editions. Improvements or changes in the products or the programs described may be made at any time.

GOVERNMENT END USERS

The Software Program and any related documentation are "Commercial Items," as that term is defined in 48 C.F.R. 2.101, "Computer Software" and "Commercial Computer Software Documentation," as such terms are used in 48 C.F.R. 12.212 or 48 C.F.R. 227.7202, as applicable. Consistent with 48 C.F.R. 12.212 or 48 C.F.R. 227.7202-1 through 227.7207-4, as applicable, the Commercial Computer Software and Commercial Software Documentation are licensed to the U.S. Government end users (a) only as Commercial Items and (b) with only those rights as are granted to all other end users pursuant to the terms and conditions herein.

Supplies

Standard supplies for this product that can be replaced by the user include toner cartridges.

Be sure to use only SHARP-specified products for the toner cartridges.

| | |
|---|--|
|  <p>SHARP GENUINE SUPPLIES</p> | <p>For best copying results, be sure to use only Sharp Genuine Supplies which are designed, engineered, and tested to maximize the life and performance of Sharp products. Look for the Genuine Supplies label on the toner package.</p> |
|---|--|

Noise emission levels

The following measurements were made in accordance with ISO 7779 and reported in conformance with ISO 9296.

Note: Some modes may not apply to your product.

| 1-meter average sound pressure, dBA | |
|-------------------------------------|--------------------------------|
| Printing | One-sided: 56 Two-sided: 55 |
| Scanning | 58 |
| Copying | 59 |
| Ready | 14 |

Waste from Electrical and Electronic Equipment (WEEE) directive



India E-Waste notice



This product including components, consumables, parts and spares complies with the “India E-Waste Rules” and prohibits use of lead, mercury, hexavalent chromium, polybrominated biphenyls or polybrominated diphenyl ethers in concentrations exceeding 0.1% by weight and 0.01% by weight for cadmium, except for the exemption set in the Rule.

Lithium-ion rechargeable battery



This product may contain a coin-cell, lithium-ion rechargeable battery, which should only be removed by a trained technician. Crossed-out wheeled bin means the product should not be discarded as unsorted waste but must be sent to separate collection facilities for recovery and recycling. In the event the battery is removed, do not dispose of the battery in your household waste. There may be separate collection systems for batteries in your local community, such as a battery-recycling drop-off location. The separate collection of waste batteries assures appropriate treatment of waste including reuse and recycling and prevents any potential negative effects on human health and environment. Please responsibly dispose of the batteries.

Information on disposal

Information on the disposal of this equipment and its batteries

IF YOU WISH TO DISPOSE OF THIS EQUIPMENT, DO NOT USE THE ORDINARY WASTE BIN, AND DO NOT PUT THEM INTO A FIREPLACE!

Used electrical and electronic equipment and batteries should always be collected and treated SEPARATELY in accordance with local law.

Separate collection promotes an environment-friendly treatment, recycling of materials, and minimizing final disposal of waste. IMPROPER DISPOSAL can be harmful to human health and the environment due to certain substances! Take USED EQUIPMENT to a local, usually municipal, collection facility, where available. This equipment contains a BATTERY which cannot be removed by the user. For battery exchange, please contact your dealer.

If in doubt about disposal, contact your local authorities or dealer and ask for the correct method of disposal.

ONLY FOR USERS IN THE EUROPEAN UNION, AND SOME OTHER COUNTRIES; FOR INSTANCE NORWAY AND SWITZERLAND: Your participation in separate collection is requested by law.



Users from PRIVATE HOUSEHOLDS are requested to use existing return facilities for used equipment. Return is free of charge.

The symbol shown above appears on electrical and electronic equipment (or the packaging) to remind the users of this. If the equipment has been used for BUSINESS PURPOSES, please contact your SHARP dealer who will inform you about take-back. You might be charged for the costs arising from take-back. Small equipment (and small quantities) might be taken back by your local collection facility. For Spain: Please contact the established collection system or your local authority for take-back of your used products.

Cartridge disposal and treatment

Regarding your used Sharp toner cartridges and other consumables from Sharp copiers/multifunctional machines, please observe that these waste products shall be treated properly according to the legal requirements in your area. We recommend to contact competent service providers (e.g. waste recycling companies) for this, and to ask local authorities for support, when necessary. For information on existing Sharp collection and recycling programs, which exist in some countries, please see our website www.sharp.eu.

Blue Angel

For Sharp Multifunctional Copiers/Printer which are certified with the German environmental label Blue Angel, please find detailed information on the websites of our respective national sales company: <http://www.sharp.eu>

Static sensitivity notice



This symbol identifies static-sensitive parts. Do not touch the areas near these symbols without first touching a metal surface in an area away from the symbol.

To prevent damage from electrostatic discharge when performing maintenance tasks such as clearing paper jams or replacing supplies, touch any exposed metal frame of the printer before accessing or touching interior areas of the printer even if the symbol is not present.

ENERGY STAR

Any product bearing the ENERGY STAR® emblem on the product or on a start-up screen is certified to comply with Environmental Protection Agency (EPA) ENERGY STAR requirements as of the date of manufacture.



Temperature information

| | |
|--|--|
| Operating temperature and relative humidity | 10 to 32.2°C (50 to 90°F) and 15 to 80% RH 15.6 to 32.2°C (60 to 90°F) and 8 to 80% RH Maximum wet-bulb temperature ² : 22.8°C (73°F) Non-condensing environment |
| Printer / cartridge / imaging unit long-term storage ¹ | 15.6 to 32.2°C (60 to 90°F) and 8 to 80% RH Maximum wet-bulb temperature ² : 22.8°C (73°F) |
| Printer / cartridge / imaging unit short-term shipping | -40 to 40°C (-40 to 104°F) |
| ¹ Supplies shelf life is approximately 2 years. This is based on storage in a standard office environment at 22°C (72°F) and 45% humidity. ² Wet-bulb temperature is determined by the air temperature and the relative humidity. | |

Laser notice

The printer is certified in the U.S. to conform to the requirements of DHHS 21 CFR, Chapter I, Subchapter J for Class I (1) laser products, and elsewhere is certified as a Class 1 consumer laser product conforming to the requirements of IEC 60825-1:2014, EN 60825-1:2014+A11:2021, and EN 50689:2021.

Class I laser products are not considered to be hazardous. The laser system and printer are designed so there is never any human access to laser radiation above a Class I level during normal operation, user maintenance, or prescribed service conditions. The printer has a non-serviceable printhead assembly that contains a laser with the following specifications:

Class: IIIb (3b) AlGaInP

Nominal output power (milliwatts): 15

Wavelength (nanometers): 650–670

Power consumption

Product power consumption

The following table documents the power consumption characteristics of the product.

Note: Some modes may not apply to your product.

| Mode | Description | Power consumption (Watts) |
|------------|---|----------------------------------|
| Printing | The product is generating hard-copy output from electronic inputs. | One-sided: 649 Two-sided: 396 |
| Copy | The product is generating hard-copy output from hard-copy original documents. | 684 |
| Scan | The product is scanning hard-copy documents. | 23.5 |
| Ready | The product is waiting for a print job. | 13.4 |
| Sleep Mode | The product is in a high-level energy-saving mode. | 1.0 |
| Hibernate | The product is in a low-level energy-saving mode. | 0.1 |
| Off | The product is plugged into an electrical outlet, but the power switch is turned off. | 0.1 |

The power consumption levels listed in the previous table represent time-averaged measurements. Instantaneous power draws may be substantially higher than the average.

Sleep Mode

This product is designed with an energy-saving mode called *Sleep Mode*. The Sleep Mode saves energy by lowering power consumption during extended periods of inactivity. The Sleep Mode is automatically engaged after this product is not used for a specified period of time, called the *Sleep Mode Timeout*.

| | |
|---|----|
| Factory default Sleep Mode Timeout for this product (in minutes): | 15 |
|---|----|

By using the configuration menus, the Sleep Mode Timeout can be modified between 1 minute and 120 minutes, or between 1 minute and 114 minutes, depending on the printer model. If the printer speed is less than or equal to 30 pages per minute, then you can set the timeout only up to 60 minutes or 54 minutes, depending on the printer model. Setting the Sleep Mode Timeout to a low value reduces energy consumption, but may increase the response time of the product. Setting the Sleep Mode Timeout to a high value maintains a fast response, but uses more energy.

Some models support a *Deep Sleep Mode*, which further reduces power consumption after longer periods of inactivity.

Hibernate Mode

This product is designed with an ultra-low power operating mode called *Hibernate mode*. When operating in Hibernate Mode, all other systems and devices are powered down safely.

The Hibernate mode can be entered in any of the following methods:

- Using the Hibernate Timeout
- Using the Schedule Power modes

| | |
|--|--------|
| Factory default Hibernate Timeout for this product in all countries or regions | 3 days |
|--|--------|

The amount of time the printer waits after a job is printed before it enters Hibernate mode can be modified between one hour and one month.

Notes on EPEAT-registered imaging equipment products:

- Standby power level occurs in Hibernate or Off mode.
- The product shall automatically power down to a standby power level of ≤ 1 W. The auto standby function (Hibernate or Off) shall be enabled at product shipment.

Off mode

If this product has an off mode which still consumes a small amount of power, then to completely stop product power consumption, disconnect the power supply cord from the electrical outlet.

Total energy usage

It is sometimes helpful to estimate the total product energy usage. Since power consumption claims are provided in power units of Watts, the power consumption should be multiplied by the time the product spends in each mode in order to calculate energy usage. The total product energy usage is the sum of each mode's energy usage.

Applicability of Regulation (EU) 2019/2015 and (EU) 2019/2020

Per Commission Regulation (EU) 2019/2015 and (EU) 2019/2020, the light source contained within this product or its component is intended to be used for Image Capture or Image Projection only, and is not intended for use in other applications.

Thailand NBTC technical standards conformity statement

คำประกาศเรื่องการเป็นไปตามมาตรฐานทางเทคนิคของ กสทช. ประเทศไทย

This telecommunication equipment conforms to the technical standards or requirements of NBTC.

เครื่องโทรคมนาคมและอุปกรณ์นี้มีความสอดคล้องตามมาตรฐานหรือข้อกำหนดทางเทคนิคของ กสทช.

Environmental information

Please read this part carefully. It will help you to reduce your impact on the environment and help you to reduce your costs at the same time.

Saving paper

- 1 The automated duplex printing function is for printing both sides of paper automatically without turning over the paper manually. If the machine is equipped with the automated duplex printing function, set up your

print settings on your computer to automatically print double-sided. Please use the automatic duplex printing function of this machine wherever possible.

- 2 By printing on recycled paper and thin 64 g/m² paper that meet the standard EN12281:2002 and similar quality standards, you can reduce the impact on the environment.

Saving energy

The ENERGY STAR® program is a voluntary scheme to promote the development and purchase of energy efficient models, which help to minimize environmental impact. Products which meet the stringent requirements of the ENERGY STAR program for both environmental benefits and the amount of energy consumption may carry the ENERGY STAR logo in case they have been registered with an ENERGY STAR program.

Regulatory notices for telecommunication terminal equipment

This section contains regulatory information pertaining to products that contain the analog facsimile card:

LEX-M03-002

Notice to users of the US telephone network: FCC requirements

This equipment complies with Part 68 of the FCC rules and the requirements adopted by the Administrative Council for Terminal Attachments (ACTA). On the back of this equipment is a label that contains, among other information, a product identifier in the format US:AAAEQ##TXXXX. If requested, this number must be provided to your telephone company.

This equipment uses the RJ-11C Universal Service Order Code (USOC) jack.

A plug and jack used to connect this equipment to the premises' wiring and telephone network must comply with the applicable FCC Part 68 rules and requirements adopted by the ACTA. Use a compliant telephone cord (RJ-11) that is 26 AWG or larger when connecting this product to the public switched telephone network. See your setup documentation for more information.

The Ringer Equivalence Number (REN) is used to determine the number of devices that may be connected to a telephone line. Excessive RENs on a telephone line may result in the devices not ringing in response to an incoming call. In most but not all areas, the sum of RENs should not exceed five (5.0). To be certain of the number of devices that may be connected to a line, as determined by the total RENs, contact your local telephone company. For products approved after July 23, 2001, the REN for this product is part of the product identifier that has the format US:AAAEQ##TXXXX. The digits represented by ## are the REN without a decimal point (for example, 03 is a REN of 0.3). For earlier products, the REN is shown separately on the label.

If this equipment causes harm to the telephone network, the telephone company will notify you in advance that temporary discontinuance of service may be required. If advance notice is not practical, the telephone company will notify the customer as soon as possible. You will also be advised of your right to file a complaint with the FCC.

The telephone company may make changes in its facilities, equipment, operations or procedures that could affect the operation of this equipment. If this happens, the telephone company will provide advance notice in order for you to make necessary modifications to maintain uninterrupted service.

Connection to party line service is subject to state tariffs. Contact the state public utility commission, public service commission, or corporation commission for information.

If your home has specially wired alarm equipment connected to the telephone line, ensure the installation of this equipment does not disable your alarm equipment. If you have questions about what will disable alarm equipment, consult your telephone company or a qualified installer.

The Telephone Consumer Protection Act of 1991 makes it unlawful for any person to use a computer or other electronic device, including fax machines, to send any message unless said message clearly contains in a margin at the top or bottom of each transmitted page or on the first page of the transmission, the date and time it is sent and an identification of the business or other entity, or other individual sending the message, and the telephone number of the sending machine or such business, other entity, or individual. (The telephone number provided may not be a 900 number or any other number for which charges exceed local or long-distance transmission charges.)

See your user documentation in order to program this information into your fax machine.

Notice to users of the Canadian telephone network

This product meets the applicable Innovation, Science and Economic Development Canada technical specifications.

The Ringer Equivalence Number (REN) indicates the maximum number of devices allowed to be connected to a telephone interface. The termination of an interface may consist of any combination of devices subject only to the requirement that the sum of the RENs of all the devices not exceed five. The REN is located on the product label.

This equipment uses CA11A telephone jacks.

Avis réservé aux utilisateurs du réseau téléphonique du Canada

Ce produit est conforme aux spécifications techniques d'Innovation, Sciences et Développement économique Canada.

Le numéro REN (ringer equivalence number : numéro d'équivalence de sonnerie) indique le nombre maximum d'appareils pouvant être connectés à l'interface téléphonique. En bout de ligne, le nombre d'appareils qui peuvent être connectés n'est pas directement limité, mais la somme des REN de ces appareils ne doit pas dépasser cinq. Le numéro REN est indiqué sur l'étiquette produit.

Cet équipement utilise des prises de téléphone CA11A.

Notice to users of the New Zealand telephone network

The following are special conditions for the Facsimile User Instructions. The grant of a telepermit for any item of terminal equipment indicates only that Spark has accepted that the item complies with minimum conditions for connection to its network. It indicates no endorsement of the product by Spark, nor does it provide any sort of warranty. Above all, it provides no assurance that any item will work correctly in all respects with another item of telepermitted equipment of a different make or model, nor does it imply that any product is compatible with all of Spark's network services.

This equipment shall not be set up to make automatic calls to the Spark "111" Emergency Service.

This equipment may not provide for the effective hand-over of a call to another device connected to the same line.

This equipment should not be used under any circumstances that may constitute a nuisance to other Spark customers.

This equipment is not capable, under all operating conditions, of correct operation at the higher speeds for which it is designed. Spark will accept no responsibility should difficulties arise in such circumstances.

The decadic (or pulse) dialing on this device is unsuitable for use on the Spark network in New Zealand.

For correct operation, the total of all the Ringer Equivalence Numbers (RENs) of all parallel devices connected to the same telephone line may not exceed 5. The REN of this device is located on the label.

Some parameters required for compliance with Spark's telepermit requirements are dependent on the equipment associated with this device. The associated equipment shall be set to operate within the following limits for compliance to Spark's specifications:

- There shall be no more than 10 call attempts to the same number within any 30 minute period for any single manual call initiation, and
- The equipment shall go on-hook for a period of not less than 30 seconds between the end of one attempt and the beginning of the next call attempt.
- The equipment shall be set to ensure that automatic calls to different numbers are spaced such that there is not less than 5 seconds between the end of one call attempt and the beginning of another.

Japanese telecom notice

The installed optional modem is in compliance with Japanese Telecommunication Law and has been Certified by JATE, with the following Certification Number:

A11-0160001JP

| | |
|---|-----------------------------|
|  | Lexmark International, Inc. |
| | LEX-M03-002 |
| | A11-0160001JP |

Using this product in Switzerland

This product requires a Swiss billing tone filter to be installed on any line which receives metering pulses in Switzerland.

Utilisation de ce produit en Suisse

Cet appareil nécessite l'utilisation d'un filtre de tonalité de facturation suisse devant être installé sur toute ligne recevant des impulsions de comptage en Suisse.

Verwendung dieses Produkts in der Schweiz

Für dieses Produkt muss ein schweizerischer Billing Tone Filter zur Zählzeichenübertragung für jede Leitung installiert werden, über die in der Schweiz Zeitsteuertakte übertragen werden.

Usò del prodotto in Svizzera

Questo prodotto richiede un filtro toni Billing svizzero, a installare su tutte le linee che ricevono impulsi remoti in Svizzera.

Regulatory notices for wireless products

This section contains regulatory information that applies only to wireless models.

Modular component notice

Wireless models contain the following modular component:

AzureWave AW-CM467-SUR; FCC ID:TLZ-CM467; IC:6100A-CM467

To determine which modular components are installed in your particular product, refer to the labeling on your actual product.

Exposure to radio frequency radiation

The radiated output power of this device is far below the radio frequency exposure limits of the FCC and other regulatory agencies. A minimum separation of 20 cm (8 inches) must be maintained between the antenna and any persons for this device to satisfy the RF exposure requirements of the FCC and other regulatory agencies.

Innovation, Science and Economic Development Canada

This device complies with Innovation, Science and Economic Development Canada license-exempt RSS standards. Operation is subject to the following two conditions: (1) this device may not cause interference, and (2) this device must accept any interference, including interference that may cause undesired operation of the device.

Innovation, Sciences et Développement économique Canada

Cet appareil est conforme aux normes RSS exemptes de licence d'Innovation, Sciences et Développement économique Canada. Son fonctionnement est soumis aux deux conditions suivantes : (1) cet appareil ne doit pas causer d'interférences et (2) il doit accepter toutes les interférences, y compris les celles qui peuvent entraîner un fonctionnement indésirable.

European Community (EC) directives conformity

This product is in conformity with the protection requirements of EC Council directive 2014/53/EU on the approximation and harmonization of the laws of the Member States relating to radio equipment.

Compliance is indicated by the CE marking:



Restrictions

This radio equipment is restricted to indoor use only. Outdoor use is prohibited. This restriction applies to all the countries listed in the table below:

| | | | | | | | | |
|----|----|----|----|----|---------|----|----|----|
| | | | | | | | | |
| AT | BE | BG | CH | CY | CZ | DE | DK | EE |
| EL | ES | FI | FR | HR | HU | IE | IS | IT |
| LI | LT | LU | LV | MT | NL | NO | PL | PT |
| RO | SE | SI | SK | TR | UK (NI) | | | |

EU and other countries statement of radio transmitter operational frequency bands and maximum RF power

This radio product transmits in either the 2.4GHz (2.412–2.472 GHz in the EU) or 5GHz (5.15–5.35, 5.47–5.725 in the EU) bands. The maximum transmitter EIRP power output, including antenna gain, is ≤ 20dBm for both bands.

United Kingdom (UK) conformity

This product is in conformity with the protection requirements of the Radio Equipment Regulations 2017.

Compliance is indicated by the UKCA marking:



Restrictions or requirements in the UK

This radio equipment is restricted to indoor use only. Outdoor use is prohibited.

UK statement of radio transmitter operational frequency bands and maximum RF power

This radio product transmits in either the 2.4GHz (2.412–2.472 GHz in the UK) or 5GHz (5.15–5.35, 5.47–5.725 in the UK) bands. The maximum transmitter EIRP power output, including antenna gain, is ≤ 20dBm for both bands.

Notice to users in Thailand

ประกาศถึงผู้ใช้ในประเทศไทย

This radiocommunication equipment has the electromagnetic field strength in compliance with the Safety Standard for the Use of Radiocommunication Equipment on Human Health announced by the National Telecommunications Commission.

เครื่องวิทยุคมนาคมนี้มีระดับการแผ่คลื่นแม่เหล็กไฟฟ้าสอดคล้องตามมาตรฐาน ความปลอดภัยต่อสุขภาพของมนุษย์จากการใช้เครื่องวิทยุคมนาคมที่คณะกรรมการกิจการโทรคมนาคมแห่งชาติประกาศกำหนด



Federal Communications Commission (FCC) compliance information statement

This product has been tested and found to comply with the limits for a Class A digital device, pursuant to Part 15 of the FCC Rules. Operation is subject to the following two conditions: (1) this device may not cause harmful interference, and (2) this device must accept any interference received, including interference that may cause undesired operation.

The FCC Class A limits are designed to provide reasonable protection against harmful interference when the equipment is operated in a commercial environment. This equipment generates, uses, and can radiate radio frequency energy and, if not installed and used in accordance with the instruction manual, may cause harmful

interference to radio communications. Operation of this equipment in a residential area is likely to cause harmful interference, in which case the user will be required to correct the interference at his own expense.

The manufacturer is not responsible for any radio or television interference caused by using other than recommended cables or by unauthorized changes or modifications to this equipment. Unauthorized changes or modifications could void the user's authority to operate this equipment.

Note: To assure compliance with FCC regulations on electromagnetic interference for a Class A computing device, use a properly shielded and grounded cable such as Lexmark part number 1021231 for parallel attach or 1021294 for USB attach. Use of a substitute cable not properly shielded and grounded may result in a violation of FCC regulations.

Any questions regarding this compliance information statement should be directed to:

Director of Lexmark Technology & Services
Lexmark International, Inc.
740 West New Circle Road
Lexington, KY 40550
Telephone: (859) 232-2000
E-mail: regulatory@lexmark.com

Innovation, Science and Economic Development Canada compliance statement

This Class A digital apparatus meets all requirements of the Canadian Interference-Causing Equipment Standard ICES-003.

Avis de conformité aux normes de l'Innovation, Sciences et Développement économique Canada

Cet appareil numérique de classe A est conforme aux exigences de la norme canadienne relative aux équipements pouvant causer des interférences NMB-003.

Japanese VCCI notice

製品にこのラベルが表示されている場合、
次の要件を満たしています。

この装置は、クラス A 情報技術装置です。この装置を家庭環境で使用すると電波妨害を引き起こすことがあります。この場合には使用者が適切な対策を講ずるよう要求されることがあります。 VCCI-A

この装置は、クラス A 情報技術装置です。この装置を家庭環境で使用すると電波妨害を引き起こすことがあります。この場合には使用者が適切な対策を講ずるよう要求されることがあります。 VCCI-A

Notice to users of Class A products in Brazil

Este produto não é apropriado para uso em ambientes domésticos, pois poderá causar interferências eletromagnéticas que obrigam o usuário a tomar medidas necessárias para minimizar estas interferências.

European Community (EC) directives conformity

This product is in conformity with the protection requirements of EC Council directives 2014/30/EU, 2014/35/EU, and 2011/65/EU as amended by (EU) 2015/863 on the approximation and harmonization of the laws of the Member States relating to electromagnetic compatibility, safety of electrical equipment designed for use within certain voltage limits, and on the restrictions of use of certain hazardous substances in electrical and electronic equipment.

This product satisfies the Class A limits of EN 55032 and safety requirements of EN 62368-1.

United Kingdom (UK) conformity

This product is in conformity with the protection requirements of the Electromagnetic Compatibility Regulations 2016, the Electrical Equipment (Safety) Regulations 2016, and the Restriction of the Use of Certain Hazardous Substances in Electrical and Electronic Equipment Regulations 2012.

This product satisfies the Class A limits of BS EN 55032 and safety requirements of BS EN 62368-1.

Radio interference notice

Warning

This is a product that complies with the emission requirements of EN 55032 Class A limits and immunity requirements of EN 55035. This product is not intended to be used in residential/domestic environments.

This is a Class A product. In a domestic environment, this product may cause radio interference, in which case the user may be required to take adequate measures.

Index

A

- activating Voice Guidance 24
- adding a shortcut
 - copy 83
- adding apps to home screen 20
- adding contact groups 23
- adding contacts 23
- adding hardware options
 - print driver 47
- adding internal options
 - print driver 47
- adding printers to a computer 45
- adding shortcut
 - e-mail 84
 - fax destination 86
 - FTP address 90
- Address Book
 - using 23
- ADF pick roller
 - cleaning 204
 - replacing 195
- ADF registration
 - adjusting 269
- ADF rollers
 - cleaning 204
 - replacing 195
- ADF separator roller
 - cleaning 204
 - replacing 195
- adjusting
 - scanner registration 269
- adjusting ADF registration 269
- adjusting brightness
 - of display 208
- adjusting default volume
 - headphone 26
 - speaker 26
- adjusting fax darkness 87
- adjusting speech rate
 - Voice Guidance 26
- adjusting toner darkness 80
- AirPrint
 - using 76
- analog fax
 - setting up 26
- answering machine
 - setting up 28

- assigning printer to a ring pattern 32
- attaching cables 18
- avoiding paper jams 239

B

- black pages 223
- blank pages 211
- blocking junk faxes 87
- bookmarks
 - creating 22
 - creating folders for 23

C

- caller ID is not shown 258
- canceling a print job 80
- cannot connect printer to Wi-Fi 252
- cannot detect internal option 253
- cannot open Embedded Web Server 251
- cannot receive faxes using analog fax 261
- cannot scan to a computer 263
- cannot scan to a network folder 264
- cannot send e-mails 258
- cannot send or receive faxes using analog fax 259
- cannot send the fax cover page from the computer 262
- Card Copy 83
 - setting up 21
- changing fax resolution 86
- changing the wallpaper 22
- checking the status of parts and supplies 177
- cleaning
 - exterior of the printer 200
 - interior of the printer 200
- cleaning the ADF pick roller 204
- cleaning the ADF rollers 204
- cleaning the ADF separator roller 204
- cleaning the printer 200
- Cleaning the Scanner 175
- cleaning the scanner 201

- cleaning the touch screen 200
- clearing jam
 - in automatic document feeder 249
 - in door A 242
 - in door B 245
 - in the duplex unit 246
 - in the multipurpose feeder 248
 - in trays 247
- collated printing does not work 255
- collating copies 82
- computer
 - connecting to the printer 73
- computer, scanning to 89
- confidential documents do not print 233
- confidential print jobs
 - configuring 78
 - printing 79
- configuring daylight saving time 33
- configuring fax speaker settings 33
- configuring supply notifications 177
- configuring the e-mail server settings 33
- configuring Wi-Fi Direct 72
- connecting a computer to the printer 73
- connecting mobile device to printer 72
- connecting the printer to a wireless network 71
- connecting to a wireless network using PIN method 71
- connecting to a wireless network using Push Button method 71
- conserving supplies 208
- contacting your dealer 270
- control panel
 - using 10
- convenience stapler
 - installing 65
 - red indicator light 254
- copy quality problem
 - partial copies of documents 265

- partial copies of photos 265
- poor copy quality 266
- vertical dark streaks 266
- copying
 - on both sides of the paper 82
 - on letterhead 82
 - photos 81
 - separator sheets between copies 82
 - using the automatic document feeder (ADF) 81
 - using the scanner glass 81
- copying cards 83
- copying different paper sizes 81
- copying from
 - selected tray 81
- copying multiple pages
 - onto a single sheet 83
- copying problem
 - scanner does not close 268
 - scanner does not respond 269
- creating a shortcut
 - copy 83
 - network folder 91
- creating bookmarks 22
- creating folders
 - for bookmarks 23
- creating shortcut
 - e-mail 84
 - fax destination 86
 - FTP address 90
- creating shortcuts 21
- crooked print 223
- customizing the display 22

D

- dark print 212
- date and time
 - fax settings 33
- daylight saving time
 - configuring 33
- deactivating the Wi-Fi network 73
- deactivating Voice Guidance 24
- default headphone volume
 - adjusting 26
- default speaker volume
 - adjusting 26
- Defective flash detected 253
- deleting contact groups 23
- deleting contacts 23
- different paper sizes, copying 81

- directory list
 - printing 80
- disabling SMTP server not set up error 257
- display brightness
 - adjusting 208
- Display Customization
 - using 22
- displaying apps on home screen 20
- distinctive ring
 - fax setup 32
- documents, printing
 - from a computer 76
- dots on print 220

E

- editing contacts 23
- emission notices 272, 281, 284
- enabling distinctive ring 32
- enabling Magnification mode 25
- enabling personal identification numbers 26
- enabling spoken passwords 26
- enabling the USB port 239
- enabling Wi-Fi Direct 72
- enlarging a copy size 82
- envelope seals when printing 255
- environmental settings 208
- erasing
 - printer memory 74
- erasing printer memory 75
- erasing printer storage drive 74
- Ethernet port 18
- exporting a configuration file
 - using the Embedded Web Server 47
- EXT port 18
- e-mail
 - sending 84
- e-mail alerts
 - setting up 177
- e-mail function
 - setting up 33
- e-mail server
 - configuring 33
- e-mail service providers 33
- e-mail shortcut
 - creating 84
- e-mail troubleshooting
 - cannot send e-mails 258

- e-mailing
 - using the automatic document feeder (ADF) 84
 - using the scanner glass 84

F

- factory default settings
 - restoring 75
- fax
 - sending 85
- fax darkness
 - adjusting 87
- fax destination shortcut
 - creating 86
- fax driver
 - installing 45
- fax log
 - printing 87
- fax resolution
 - changing 86
- fax server, using
 - setting up the fax function 27
- fax setup
 - standard telephone line connection 28
 - using different plugs 30
 - using different wall jacks 30
- fax speaker settings
 - configuring 33
- fax troubleshooting
 - caller ID is not shown 258
 - can send but not receive faxes
 - using analog fax 261
 - cannot send faxes using analog fax 261
 - cannot send or receive faxes
 - using analog fax 259
 - cannot send the fax cover page
 - from the computer 262
 - missing information on the fax cover page 262
 - poor print quality 262
- fax, scheduling 86
- faxing
 - setting the date and time 33
 - using the automatic document feeder (ADF) 85
 - using the scanner glass 85
- FCC notices 281
- fine lines not printed
 - correctly 214
- firmware card 47

firmware, updating 46
flash drive
 printing from 77
 scanning to 91
folder paper 215
font sample list
 printing 80
forwarding fax 87
FTP address
 creating shortcut 90
FTP server, scanning to
 using the control panel 90

G
genuine parts and supplies 178
gray background on prints 216

H
hard disk 47
 erasing 74
hard disk storage drive 75
hardware options
 trays 48
hardware options, adding
 print driver 47
held documents do not print 233
held jobs
 printing 79
 setting expiration time 78
Hibernate mode
 configuring 208
holding faxes 87
home screen
 customizing 20
 using 19
home screen icons
 displaying 20
horizontal light bands 226
humidity around the printer 275

I
icons on the home screen
 showing 20
images cut off on print 224
imaging unit
 ordering 178
 replacing 181
importing a configuration file
 using the Embedded Web
 Server 47
incorrect margins 218

indicator light
 understanding the status 10
installing a printer hard disk 53
installing convenience stapler 65
installing internal options
 intelligent storage drive 49
 Trusted Platform Module 60
installing options
 printer hard disk 53
installing the fax driver 45
installing the print driver 45
installing the printer software 45
installing trays 48
installing wireless print server 63
intelligent storage drive 47, 75
 erasing 74
 installing 49
internal options 47
 printer hard disk 53
internal options, adding
 print driver 47

J
jagged image
 scanning from ADF 267
jagged text
 scanning from ADF 267
jam locations
 identifying 240
jammed pages are not
 reprinted 257
jams, paper
 avoiding 239
job prints from the wrong
 tray 234
job prints on the wrong
 paper 234
junk faxes
 blocking 87

L
letterhead
 copying on 82
 selecting 12
light print 218
LINE port 18
linking trays 44
loading envelopes
 in the multipurpose feeder 43
loading letterhead 41
 in the multipurpose feeder 43

loading paper 41
loading trays 41
locating paper jams 240
locating the security slot 74

M

Magnification mode
 enabling 25
making copies 81
managing screen saver 22
MarkNet N8450 Wireless Print
Server 63
menu
 802.1x 163
 About this Printer 108
 Accessibility 101
 AirPrint 156
 Anonymous Data Collection 101
 Confidential Print Setup 171
 Configuration Menu 102
 Copy Defaults 118
 Custom Scan Sizes 117
 Device 173
 Disk Encryption 172
 Eco-Mode 96
 Erase Temporary Data Files 172
 Ethernet 158
 E-mail Defaults 138
 E-mail Setup 137
 Fax 174
 Fax Cover Page 122
 Fax Log Settings 122
 Fax Mode 122
 Fax Receive Settings 122
 Fax Send Settings 122
 Fax Server E-mail Settings 134
 Fax Server Scan Settings 134
 Fax Server Setup 134
 Fax Setup 122
 Flash Drive Print 151
 Flash Drive Scan 148
 Forms Merge 175
 FTP Defaults 144
 General Fax Settings 122, 134
 H.323 Settings 122
 Home Screen
 Customization 107
 HTTP/FTP Settings 164
 HTTPS Fax Settings 122
 Image 115
 IPSec 161
 Job Accounting 111

- Layout 108
 - Local Accounts 167
 - Login Restrictions 171
 - LPD Configuration 163
 - Manage Permissions 166
 - Media Types 118
 - Menu Settings Page 173
 - Miscellaneous 172
 - Mobile Services
 - Management 157
 - Network 175
 - Network Overview 153
 - Notifications 97
 - Out of Service Erase 106
 - PCL 113
 - PDF 112
 - PostScript 113
 - Power Management 100
 - Preferences 94
 - Print 174
 - Quality 110
 - Remote Operator Panel 97
 - Restore Factory Defaults 102
 - Restrict external network
 - access 165
 - Schedule USB Devices 168
 - Security Audit Log 168
 - Setup 109
 - Shortcuts 174
 - SIP Settings 122
 - SNMP 160
 - Solutions LDAP Settings 172
 - Speaker Settings 122
 - T.38 Settings 122
 - TCP/IP 159
 - ThinPrint 164
 - Tray Configuration 116
 - Troubleshooting 175
 - Universal Setup 116
 - Update Firmware 107
 - USB 165
 - VoIP Settings 122
 - Web Link Setup 143
 - Wireless 153
 - Wi-Fi Direct 156
 - Menu Settings Page
 - printing 176
 - missing information on the fax cover page 262
 - missing print 231
 - mobile device
 - connecting to printer 72
 - printing from 76, 77
 - mottled print 220
 - moving the printer 17, 208
 - multipurpose feeder
 - loading 43
- N**
- navigating the screen
 - using gestures 24
 - navigating the screen using gestures 24
 - network folder
 - creating a shortcut 91
 - network setup page
 - printing 73
 - noise emission levels 272
 - nonvolatile memory
 - erasing 74
 - non-volatile memory 75
 - Not enough free space in flash memory for resources 254
 - notices 272, 276, 277, 281, 284
- O**
- on-screen keyboard
 - using 25
 - optional cards 47
 - ordering supplies
 - imaging unit 178
 - toner cartridge 178
- P**
- paper
 - letterhead 12
 - preprinted forms 12
 - selecting 10
 - unacceptable 12
 - Universal size setting 41
 - paper characteristics 11
 - paper curl 221
 - paper frequently jams 256
 - paper guidelines 10
 - paper jam in automatic document feeder 249
 - paper jam in door A 242
 - paper jam in door B 245
 - paper jam in the duplex unit 246
 - paper jam in the multipurpose feeder 248
 - paper jam in trays 247
 - paper jams
 - avoiding 239
 - locating 240
 - paper sizes, supported 13
 - paper types, supported 15
 - paper weights, supported 16
 - partial copies of documents 265
 - partial copies of photos 265
 - parts status
 - checking 177
 - personal identification number method 71
 - personal identification numbers
 - enabling 26
 - photos, copying 81
 - pick tires
 - replacing 191
 - placing separator sheets 80
 - between copies 82
 - poor copy quality 266
 - poor fax print quality 262
 - power cord socket 18
 - power save modes
 - configuring 208
 - power supply
 - replacing 185
 - preprinted forms
 - selecting 12
 - print driver
 - hardware options, adding 47
 - installing 45
 - print job
 - canceling 80
 - print jobs not print 232
 - print quality problem
 - blank pages 211
 - crooked print 223
 - dark print 212
 - dots on print 220
 - fine lines not printed
 - correctly 214
 - folded paper 215
 - gray background on prints 216
 - horizontal light bands 226
 - incorrect margins 218
 - light print 218
 - mottled print 220
 - paper curl 221
 - repeating defects 232
 - skewed print 223
 - solid black pages 223
 - text or images cut off 224

- toner easily rubs off 225
 - vertical dark bands 228
 - vertical dark lines or streaks 230
 - vertical dark streaks with print missing 231
 - vertical light bands 227
 - vertical white lines 228
 - white pages 211
 - wrinkled paper 215
 - print quality problems 210
 - Print Quality Test Pages 175
 - print troubleshooting
 - collated printing does not work 255
 - confidential and other held documents do not print 233
 - envelope seals when printing 255
 - job prints from the wrong tray 234
 - job prints on the wrong paper 234
 - paper frequently jams 256
 - print quality problems 210
 - tray linking does not work 256
 - unable to read flash drive 238
 - printer
 - minimum clearances 17
 - selecting a location for 17
 - shipping 209
 - printer configurations 9
 - printer dealer 270
 - printer is not responding 237
 - printer memory
 - erasing 74
 - printer menus 93, 176
 - printer messages
 - Defective flash detected 253
 - Not enough free space in flash memory for resources 254
 - Replace cartridge, printer region mismatch 254
 - printer options troubleshooting
 - cannot detect internal option 253
 - printer settings
 - restoring factory default 75
 - printer software
 - installing 45
 - printer status 10
 - printing
 - confidential print jobs 79
 - directory list 80
 - fax log 87
 - font sample list 80
 - from a computer 76
 - from a flash drive 77
 - from a mobile device 76, 77
 - held jobs 79
 - Menu Settings Page 176
 - network setup page 73
 - using Wi-Fi Direct 77
 - printing a directory list 80
 - printing a font sample list 80
 - printing a network setup page 73
 - printing from a computer 76
 - printing problem
 - print jobs do not print 232
 - slow printing 235
 - Push Button method 71
- R**
- received faxes
 - holding 87
 - red indicator light
 - on the convenience stapler 254
 - reducing a copy size 82
 - removing paper jam
 - in automatic document feeder 249
 - in door A 242
 - in door B 245
 - in the duplex unit 246
 - in the multipurpose feeder 248
 - in trays 247
 - repeat print jobs 78
 - repeating defects on print 232
 - Replace cartridge, printer region mismatch 254
 - replacing parts
 - ADF pick roller 195
 - ADF rollers 195
 - ADF separator roller 195
 - pick tires 191
 - scanner glass pad 193
 - replacing power supply 185
 - replacing staple refill 184
 - replacing supplies
 - imaging unit 181
 - toner cartridge 179
- S**
- reports
 - printer status 178
 - printer usage 178
 - resetting supply usage counters 200
 - RJ-11 adapter 30
 - running a slideshow 22
- S**
- safety information 7, 8
 - saving paper 83
 - Scan Center
 - setting up 21
 - scan job not successful 267
 - scan quality problem
 - jagged image 267
 - jagged text 267
 - partial copies of documents 265
 - partial copies of photos 265
 - poor copy quality 266
 - vertical dark streaks 266
 - scan troubleshooting
 - cannot scan to a computer 263
 - cannot scan to network folder 264
 - scanner
 - cleaning 201
 - scanner does not close 268
 - scanner does not respond 269
 - scanner glass pad
 - replacing 193
 - scanning
 - to a computer 89
 - to an FTP server 90
 - to flash drive 91
 - using the automatic document feeder (ADF) 89
 - using the scanner glass 89
 - scanning from the PDF
 - vertical dark streaks 266
 - scanning problem
 - scan job not successful 267
 - scanner does not close 268
 - scanner does not respond 269
 - scanning freezes the computer 268
 - scanning takes too long 268
 - scanning to a network folder 90
 - scanning to an FTP server
 - using the control panel 90
 - scheduling a fax 86

V

- verify print jobs 78
- vertical dark bands on prints 228
- vertical dark lines on prints 230
- vertical dark streaks 231
 - when scanning from the ADF 266
- vertical light bands 227
- vertical streaks on prints 230
- vertical white lines 228
- viewing reports 178
- Voice Guidance
 - activating 24
 - deactivating 24
 - speech rate 26
- Voice Guidance speech rate
 - adjusting 26
- volatile memory 75
 - erasing 74

W

- white pages 211
- wireless network
 - connecting the printer to 71
 - Wi-Fi Protected Setup 71
- wireless networking 71
- wireless print server
 - installing 63
- Wi-Fi Direct
 - configuring 72
 - enabling 72
 - printing from a mobile device 77
- Wi-Fi network
 - deactivating 73
- Wi-Fi Protected Setup
 - wireless network 71
- wrinkled paper 215